

magicolor 6100 Series Service Manual



1750039-001C

MINOLTA
QMS

The essentials of imaging

www.minolta-qms.com

Safety and Revision Information

Revision Control Table

No.	Date of Revision	Revision Code	Description of Revision
1	July, 1999	First Edition	First edition.
2	August, 1999	“A” Edition	Reviewed to cover the mass-production unit.
3	October, 1999	“A” Edition	Reviewed following pages: 3-3, 7-34, 7-42, 7-60, 9-1 and 9-5
4	October, 1999	QMS REV. 001	Internal manual revision. Duplexer and LFU information added.
5	March 2000	QMS REV. 001A	Final OEM information included. Format revision.
6	July 2000	Minolta-QMS Rev. 001B	Added LFU wiring diagram. Error message corrections included
7	June 2001	Minolta-QMS Rev. 001C	New OEM information included.

Note: Some pages found within this manual are 11” x 17”. If you print out the Acrobat files, please note these pages should be printed separately.

FCC NOTICE

WARNING

This equipment has been tested and found to comply with the limits for a Class A digital device, pursuant to Part 15 of the FCC Rules. These limits are designed to provide reasonable protection against harmful interference in a commercial environment. This equipment generates, uses, and can radiate radio frequency energy, and if not installed and used in accordance with the instruction manual, may cause harmful interference to radio communications. Operation of this equipment in a residential area is likely to cause harmful interference in which case the user will be required to correct the interference at his/her own expense. A shielded cable is required to comply with the limits for a Class A digital device, pursuant to Part 15 of the FCC rules.

Caution: Any modifications or changes to this product not expressly approved in writing by the manufacturer responsible for compliance to Federal Regulations could void the user's authority to operate this product within the Laws and Regulations of the Federal Communications Commission.

Canadian Compliance

This digital apparatus does not exceed the Class A limits for radio noise emissions from digital apparatus set out in the Radio Interference Regulations of the Canadian Department of Communications.

"Le present appareil numerique n'emmet pas de bruits radioelectriques depassant les limites applicables aux appareils numeriques (de la Class A) prescrites dans le Reglement sur le brouillage radioelectrique edicte par le ministere des Communications du Canada."

Product Safety

Laser Product

This engine is certified as a Class 1 laser product and complies with CDRH Laser-Radiation Standards, 21 CFR Chapter 1, Subchapter J.

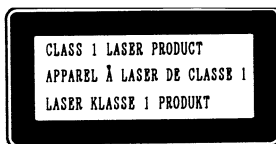

WARNING

Use of controls, adjustments or performances of procedures other than those specified in this manual may result in hazardous radiation exposure.

Ozone Gas

WARNING

This engine is provided with the ozone filter in order to reduce exhaust ozone in compliance with Product Safety Standards. The ozone filter must be replaced yearly; otherwise, it may cause a strong odor, which will likely have ill effects on bronchial tubes.

Documentation Disclaimer

QMS MAKES NO REPRESENTATION OR WARRANTIES OF ANY KIND WHATSOEVER WITH RESPECT TO THE CONTENTS HEREOF AND SPECIFICALLY DISCLAIMS ANY IMPLIED WARRANTIES OF MERCHANTABILITY OR FITNESS FOR ANY PARTICULAR PURPOSE.

i Safety Instructions

i.i Safety Principles

- i.i.i Before starting any procedure, read this manual thoroughly. Read and understand the safety instructions found in this section.
- i.i.ii When handling any P.W.B. use all necessary ESD precautions.
- i.i.iii Perform all the operations by following the procedures described in this manual. Follow all the cautions and warnings set out in the procedures and on safety labels affixed to the machine. Failure to do so may result in personal injuries or equipment damage.
- i.i.iv Perform only the procedures explained in this manual. Refrain from opening or touching any portions that are not related with your operation.
- i.i.v Repair and replacement of parts should be performed by trained and qualified service personnel only. Operators should not attempt to do such repair or replacement.
- i.i.vi It must be understood that the above-mentioned cautions and warnings do not cover everything, because it is impossible to guess at or evaluate all the circumstances beforehand.

i.ii Special Safety Information

i.ii.i Introductory Information

The warnings and cautions are made clear by “Signal Words” such as DANGER, WARNING and CAUTION.

i.ii.i.i Definition of Signal Words

DANGER is used to indicate the presence of a hazard which will cause severe human injuries or a fatal accident if ignored.

WARNING is used to indicate the presence of a hazard or unsafe practices which may cause severe human injuries or a fatal accident if ignored.

CAUTION is used to indicate the presence of a hazard or unsafe practices which may cause minor human injuries if ignored. **CAUTION** also calls attention to safety messages in this manual.

i.ii.i.ii Follow Safety Instructions

Carefully read all the safety messages set out in this manual and also in the safety signs placed on your equipment. Do not remove safety labels from products. Replace the safety labels if they become smeared or damaged. Learn how to operate the equipment and how to use the controls properly. Do not let anyone operate the equipment without reading the instructions. Keep the equipment in proper working condition. Unauthorized modification to the equipment may impair product function and safety, and affect the life of equipment.

The following are the various kinds of “**WARNINGS**” contained in this manual.

WARNING
HAZARDOUS VOLTAGE

It may cause serious injuries or fatal accidents. Voltage is now applied from the power supply of printer. There is the danger of electric shock if you touch the active area inside the printer.

Make sure to turn the power supply switch OFF and pull out the plug from the outlet before starting the maintenance work on the printer.

WARNING
HARMFUL OZONE GAS

Inhalation of an excessive amount of ozone gas may adversely affect the respiratory organs.

The ozone filter is provided in this printer to reduce the exhaust ozone. This filter must be replaced with a new filter periodically in accordance with the manual for this printer.

	⚠ WARNING Hot surface. Avoid contact.	⚠ WARNUNG Heiße oberfläche. Bei beseitigung.	⚠ AVERTISSEMENT Surface chaude. Eviter tout contact.	⚠ 高温注意 火傷の恐れがあります。 触れないでください。Ⓜ
---	--	---	---	---

The following are the various kinds of “CAUTIONS” contained in this Manual.

**CAUTION
HOT SURFACE**

Can cause serious burns.

The fusing unit is approximately 150°C, therefore, the areas around the fuser are also very hot.

When you need to change the cleaning pad or remove jammed paper, wait about 20 minutes after opening up the paper exit unit and confirm that the unit is well cooled down.

**CAUTION
ROTATING PARTS**

Be aware of the danger of getting your fingers or hand caught in the printer or associated rollers causing serious injuries. Note that the exit roller is rotating while printing.

Be careful not to get your hair, fingers, hands, sleeves or neckties caught in the printer while operating the machine.

**CAUTION
HAZARDOUS POWDER**

Toner is a fine powder known to cause a powder explosion if dumped into open fire. Strictly refrain from dumping toner into the fire for disposal.

Toner is a fine powder known to cause problems with eyes, and problems with respiratory organs if inhaled.

Handle the toner cartridge, waste toner pack, and developing unit carefully.

**CAUTION
POWER CORD AND PLUG**

This printer is equipped with a 3-wire power cord and 3-pronged plug (bipolar plug with grounding) for user safety.

Connect the power cord to a properly grounded electrical receptacle to avoid an electric shock.

CAUTION
SAFETY INTERLOCK

Cover and paper delivery unit of this printer have electric safety interlocks to turn the power off whenever they are opened. Do not attempt to circumvent these safety interlocks.

CAUTION

Do not step on or lean against the paper cassette. Failure to follow this guideline may cause the printer to tip over. This may cause injuries or it may damage the printer.

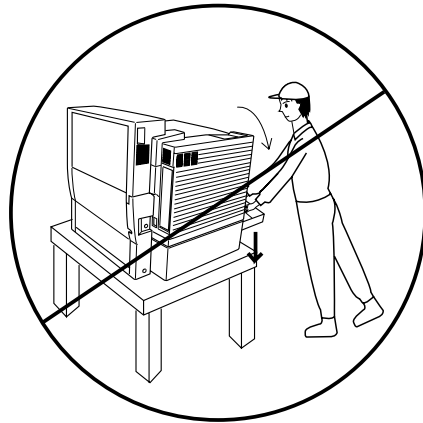

Do not step on or lean against the printer door. Failure to follow this guideline may cause the printer to tip over. This may cause injuries or it may damage the printer.

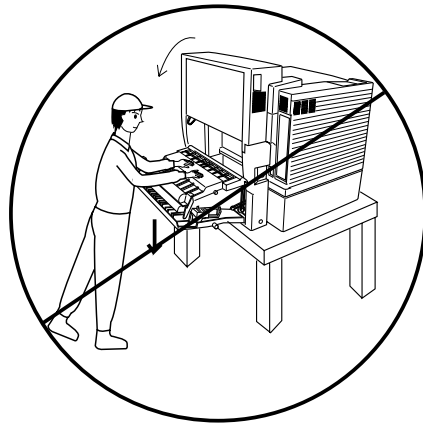

i Safety Instructions	v
i.i Safety Principles	v
i.ii Special Safety Information	vi
1.0 Outline of Product	1-3
1.1 Name and Function of Components	1-3
1.2 Name and Function of Duplexer Components	1-4
1.3 Name and Function of LFU Components	1-5
1.4 Internal Structure of the Printer	1-6
1.5 Internal Structure of the Duplexer	1-7
1.6 Description of The Operator Panel	1-8
2.0 Specifications	2-3
2.1 Rating	2-3
2.2 Printer Specifications	2-4
2.3 Environmental Conditions	2-8
3.0 Installation	3-3
3.1 Conditions for Installation	3-3
3.2 Unpacking	3-4
3.3 Installation	3-9
4.0 Theory of Operation	4-3
4.1 Basic Structure	4-3
4.2 Print System and Transfer/Transport System	4-7
4.3 Optical System	4-22
4.4 Paper Transportation System	4-24
4.5 Fuser	4-25
4.6 Structure of the Control System	4-27
5.0 Periodic Maintenance	5-3
5.1 General	5-3
5.2 Cleaning for Periodic Maintenance	5-5
5.3 Periodic Maintenance Cycles and Procedures	5-13
6.0 Operation of and Adjustments through the Operator Panel	6-3
6.1 Panel Layout	6-3
6.2 Display Modes	6-4
6.3 Operation of Normal Mode	6-7
6.4 Service Mode	6-12
6.5 Adjustment Procedures	6-37
7.0 Replacement Procedures	7-3
7.1 Replacement of Covers	7-5
7.2 Replacement of Printed Wire Boards (P.W.B)	7-19

7.3 Replacement of Motor Units.....	7-33
7.4 Replacement of Clutches	7-47
7.5 Replacement of Switches and Sensors	7-51
7.6 Replacement of Rollers, Drums, and Other Components.....	7-69
7.7 Replacement of the Fuser	7-80
7.8 Duplexer Replacement Procedures.....	7-83
7.9 Replacement of Lower Feed Unit Parts	7-107
8.0 Troubleshooting.....	8-3
8.1 Troubleshooting Outline.....	8-3
8.2 Operator Call Error Codes	8-4
8.3 Paper Transport Errors	8-34
8.4 Printer Errors (non-Operator Call Errors).....	8-37
8.5 Imaging Failures.....	8-72
9.0 Spare Parts Breakdown	9-3
Index	I-3

Section 1:
Outline of Product

1.0 Outline of Product

1.1 Name and Function of Components

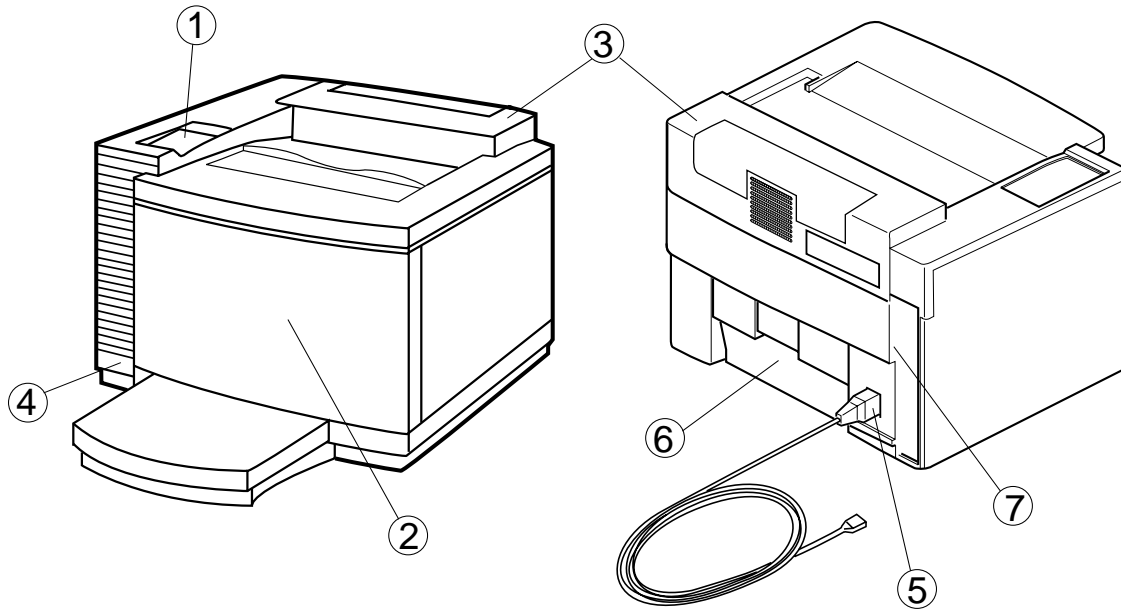

Fig. 1-1

Number	Name of Part	Function of Part
1	Operator Panel	Displays a status of printer operation.
2	Front Door	Acts as a front enclosure. Open when replacing toner cartridges or waste toner packs.
3	Paper Exit Unit	Acts as an enclosure for the paper exit and output paper tray.
4	Main Switch	Powers On/Off the printer.
5	Power Connection	Connects to a power supply cable.
6	Transfer Unit Door	Acts as a rear enclosure. Open when clearing an internal jam or performing maintenance.
7	Interface Connector Panel	Video controller PWB installation location.

1.2 Name and Function of Duplexer Components

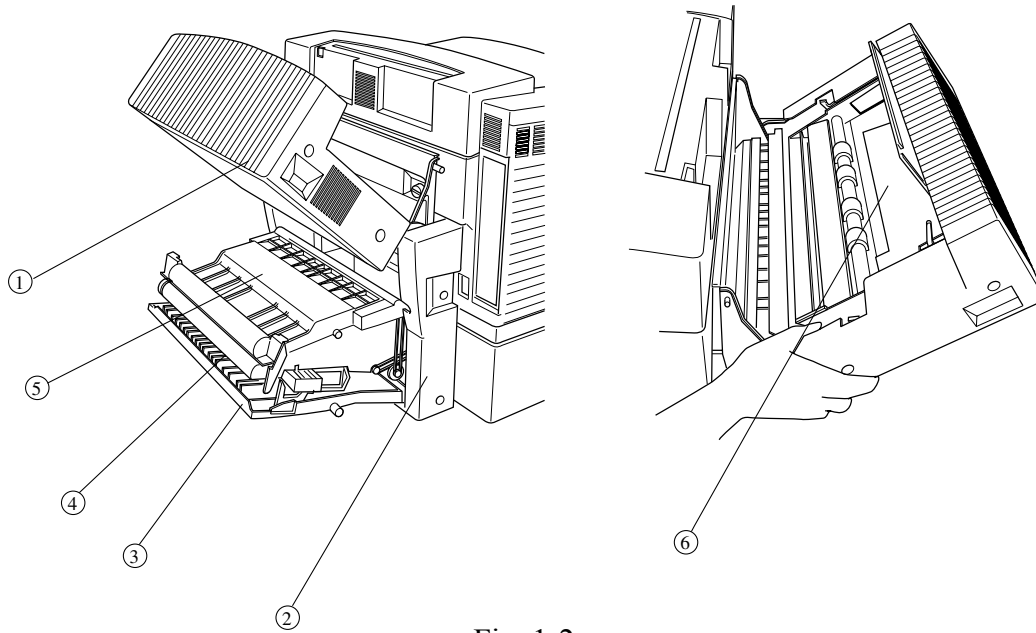

Fig. 1-2

Number	Name of Part	Function of Part
1	Top Unit	Transports the front side of the page to the duplexer.
2	Lower Unit	Reverses the front page for printing on the back page.
3	Lower-rear Cover	Open for clearing an inner jam or performing maintenance. Rear enclosure.
4	Reverse Paper Guide Unit	Open for clearing inner jams or performing maintenance. Paper reverse and transport unit.
5	Reverse Input Paper Guide	Open for clearing inner jams or performing maintenance. Paper reverse and transport guide.
6	Paper Guide FU	Open for clearing "DUPLEX JAM." Paper transportation guide in D-top unit.

1.3 Name and Function of LFU Components

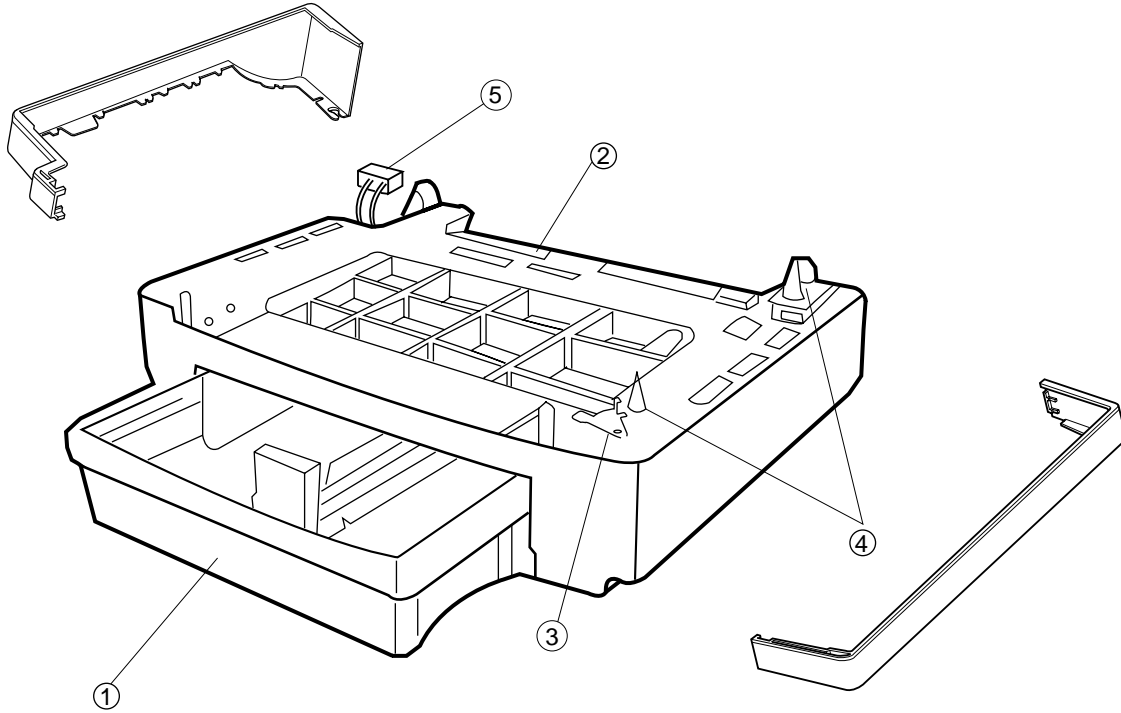

Fig. 1-3

Number	Name of Component	Function of Component
1	Paper Cassette	Holds paper.
2	Paper Guide	Guides paper from paper cassette to printer.
3	Tray Latch	Secures LFU to printer.
4	Connector Pin	Aligns the printer engine with the lower feeder unit.
5	Signal Connector	Activates lower feeder unit through electrical signal.

1.4 Internal Structure of the Printer

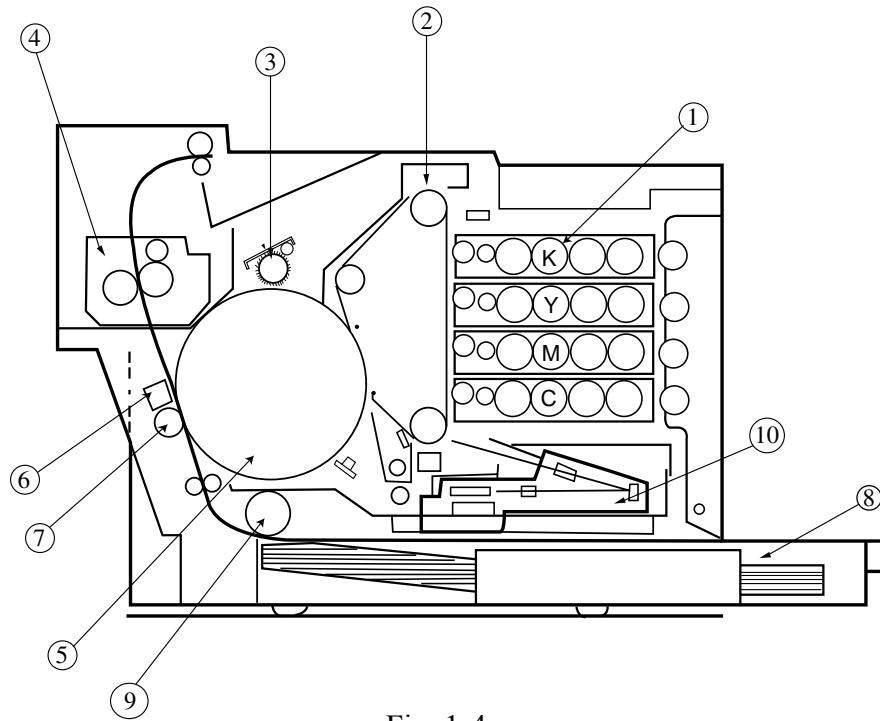

Fig. 1-4

Number	Name of Component	Function of Component
1	Toner Cartridge	Contains the independent toner cartridges (K, Y, M, C) used during the development process.
2	OPC Belt Cartridge	Holds the latent image for development. After development of each color layer, the image is transferred to the drum.
3	Drum Cleaner	Cleans and collects waste toner left adhering to the transfer drum.
4	Fuser	Fuses toner images on the paper using heat and pressure.
5	Transfer Drum	Receives each color layer from the OPC. Holds the completed image to be transferred to the paper.
6	Paper Discharger	Separates a sheet of paper from the transfer drum.
7	Transfer Roller	Transfers the toner image from the transfer drum to paper.
8	Paper Cassette	Holds paper to be fed into the printer.
9	Pick-up Roller	Feeds paper automatically from the paper cassette.
10	Optical Unit	Creates a latent image on the OPC belt.

1.5 Internal Structure of the Duplexer

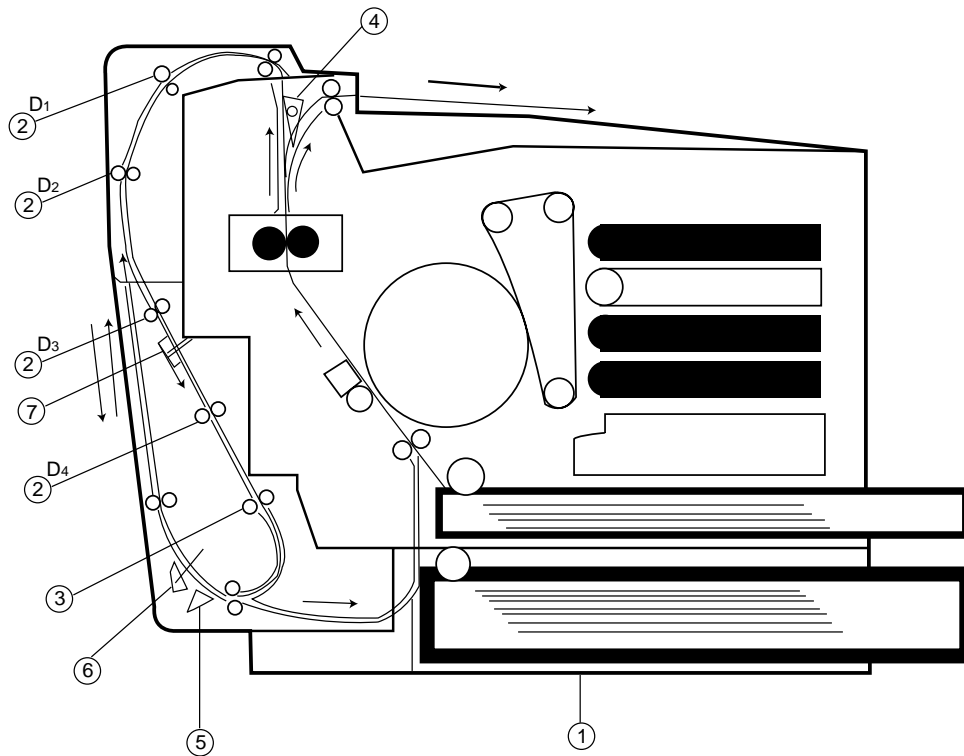
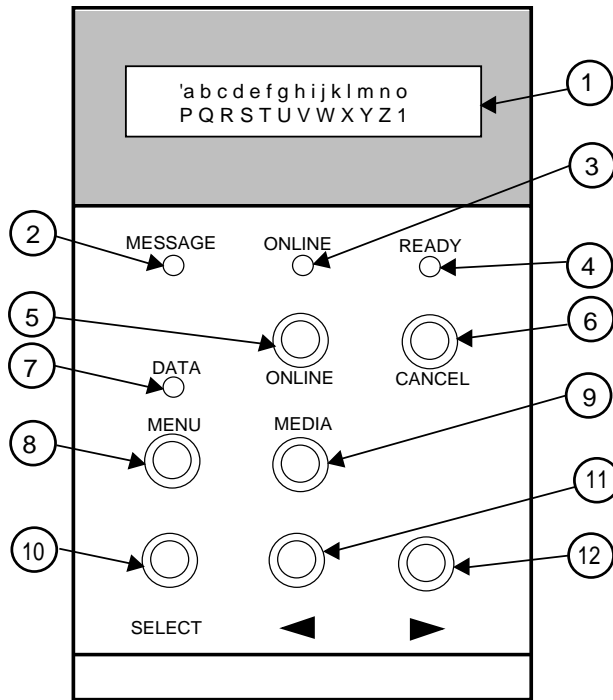

Fig. 1-5

Number	Name of Component	Function of Component
1	Lower Feed Unit (LFU)	Feeds paper to printer. Required for duplex operation.
2	Transport Rollers (D1 - D4)	Transports paper.
3	Registration Roller	Performs registration for back side of paper.
4	Shutter AS (U)	Switches paper to the duplexer.
5	Shutter AS (L)	Switches paper from the duplexer.
6	Sensor PT4	Senses paper.
7	Sensor PT5	Senses paper.

1.6 Description of The Operator Panel



Number	Description
1	LCD: 16 characters by 2 lines
2	Message LED
3	Online LED
4	Ready LED
5	Online Key
6	Cancel Key
7	Data LED (Red)
8	Menu Key
9	Media Key
10	Select Key
11	Scroll Key (Left)
12	Scroll Key (Right)

Section 2:
Product Specifications

2.0 Specifications

2.1 Rating

WARNING

Use the power supply cord provided, or a similar cord complying with following specifications: 3-wire power cord with grounding. Using a cord that does not adhere to these specifications may result in an electric shock.

Printer Version	Voltage (V)	Frequency (Hz)	Input Current (A)	Power Cord
United States	120	50/60	11	1 (Standard)
Europe	220 - 240	50/60	6	Not included. *1
Japan	100	50/60	13	1 (Standard)

*1:European customers must purchase and use a power cord complying with the following specifications.

Figure	Model Name	Rating	Approval Agency	Applicable Area
A	H05VV-F3G0.75	250VAC, 6A	VDE, OVE, SEMKO, CEBEC, NEMKO, DEMKO, FIMKO	Europe (Continent)
B	H05VV-F3-0.75	250VAC, 6A	BS	UK

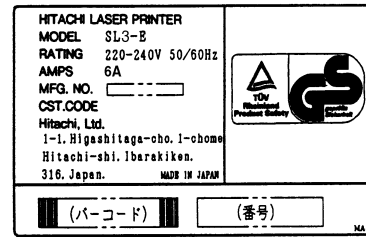
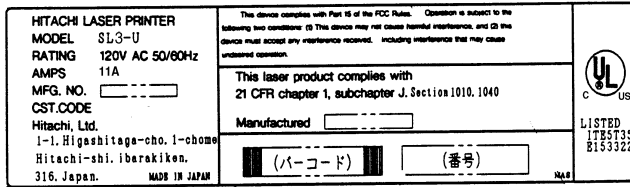

Fig. A: Power Cord for Europe

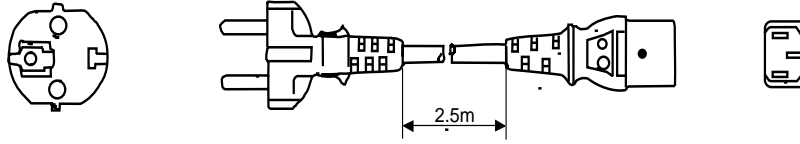
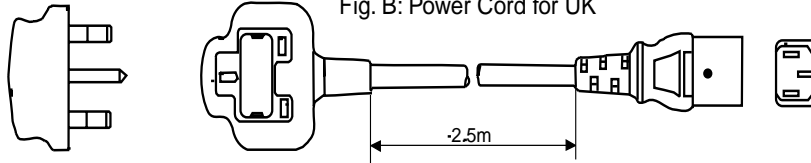

Fig. B: Power Cord for UK



2.2 Printer Specifications

Number	Item	Description/Specification
1	Printing Method	Semiconductor laser and electrophotographic print.
2	Scanning Method	Semiconductor laser with rotating mirror.
3	Recording Method	Black writing electrophotographic.
4	Processing Method	Cyan, Magenta, Yellow, and Black toner image transfer to print media.
5	Fusing Method	Heated rollers.
6	Print Speed a). Monochrome b). Two-Color c). Three-Color d). Four-Color	a). 24 Letter/A4; 12 Tabloid/A3 b). 12 Letter/A4; 6 Tabloid/A3 c). 8 Letter/A4; 4 Tabloid/A3 d). 6 Letter/A4; 3 Tabloid/A3
37	Warm-Up Time (Ambient Temperature 68° F or 20° C)	210 seconds maximum
84	Resolution	600 dpi (base unit)
9	Feeding Method	Cassette Feed

Number	Item	Description/Specification
10	Cassette Capacity	Standard Paper: 250 sheets, OHP: 50 sheets, Envelope: 30 envelopes (15 envelopes under humid conditions), Post Card: 50
11	Media	Letter, Legal, Executive (A4), OHP, Label, Envelope, A3 Nobi, A3
12	Paper Exit	Face Down, 250 sheets
13	External Dimension	24.2" (W) x 21.3" (D) x 16.5" (H) 615 mm (W) x 540 mm (D) x 420 mm (H)
14	Acoustic Noise	Standby: 48dB (A) Printing: 55dB (A), 60dB (A) at maximum
15	Weight of Printer	Without Consumables: Approx. 101 lbs/46kg With Consumables: Approx. 119 lbs/54kg

2.2.1 Lower Feed Unit Specifications

Number	Item	Description/Specification
1	Lower Feed Unit	Option for printer
2	Cassette Capacity	Paper: 500 sheets
3	Media Sizes	Letter, Legal, A4, Executive, B5, Label, Ledger
4	Dimensions	19.5" (W) x 19" (D) x 4.5" (H) 500mm (W) x 484mm (D) x 116mm (H)
5	Weight	Approximately 17.6 lbs (11kg)

2.2.2 Duplexer Specifications

Number	Item	Description/Specification
1	Duplexer	Option for printer

Number	Item	Description/Specification
2	Mandatory Option	Lower Feeder Unit
3	Media Sizes	Letter, Legal, A3 Nobi, A3, A4
4	Cassette Capacity	Face-Down Output Tray: 250 sheets Lower Feed Unit: 500 sheets
5	Rated Voltage	24VDC to be supplied from Printer
6	Dimensions	Duplexer: 19.1" (W) x 7.8" (D) x 23.1" (H) 485mm (W) x 198mm (D) x 588mm (H). Printer with Duplexer: 24.2" (W) x 24.4" (D) x 24" (H) 615mm (W) x 620mm (D) x 610mm (H)
7	Weight	Duplexer: Approx. 26.5 lbs. (12kg) Printer with Duplexer and Lower Feed Unit: Approx. 169.9 lbs. (77kg)

Table 2-1: Characteristics of OEM Paper

Item	Description
Basis Weight (g/m ²)	82 ± 5
Thickness (μm)	95 ± 6
Smoothness (Bekk)	90 ± 20
Stiffness (Clark)	100 ± 15
Brightness (%)	85 ± 2
Surface Resistance (¾)	10 ¹⁰ ~ 10 ¹¹
Grain Direction	Long

Table 2-2: Characteristics of OEM Recommended Paper and Other Media

		Paper Xerox 4024	Paper Hammermill Laserprint	Label Avery 5260	OHP Sheet	SPHINX Auto Fil #1914
Paper Weight (g/m ²)		75 ± 4	90 ± 4	163 ± 7	142 ± 4	90 ± 4
Thickness (μm)		102 ± 6	105 ± 6	184 ± 7	110 ± 6	125 ± 10
Smoothness (Bekk)		35 ± 4	120 ± 20	20 ± 6	500 ± 100	22 ± 10
Stiffness (Clark)		100 ± 15	90 ± 15	65 ± 15	56 ± 15	70 ± 20
Surface Resistance x 10 ⁹ (¾)		10 ~ 100	10 ~ 100	1 ~ 100	10 ~ 1000 ^a 10 ~ 1000 ^b	1 ~ 100
CIE	L*	94 ± 2	94 ± 2	94 ± 2	Š 80% (Transmittance)	
LAB	a*	0.4 ± 1	-0.5 ± 1	-0.2 ± 1		
L*a*b*	b*	1.6 ± 1	2.2 ± 1	4.5 ± 1		
Brightness (%)		80 ± 2	85 ± 2	77 ± 3	---	82 ± 5
Grain Direction		Long	Long	Long	---	---

a. Printed side.

b. Back side.

Measurement Conditions: 63.5 to 81°F (17.5 ~ 27.0°C) and 50 ~ 70% RH

Note: Keep the paper sealed. Do not open the paper until using it.

2.3 Environmental Conditions

2.3.1 Ambient Temperature / Humidity / Altitude:

2.3.1.1 Operating: 10.0 ~ 32.5°C, 20 ~ 80% RH
(See the figure below.)

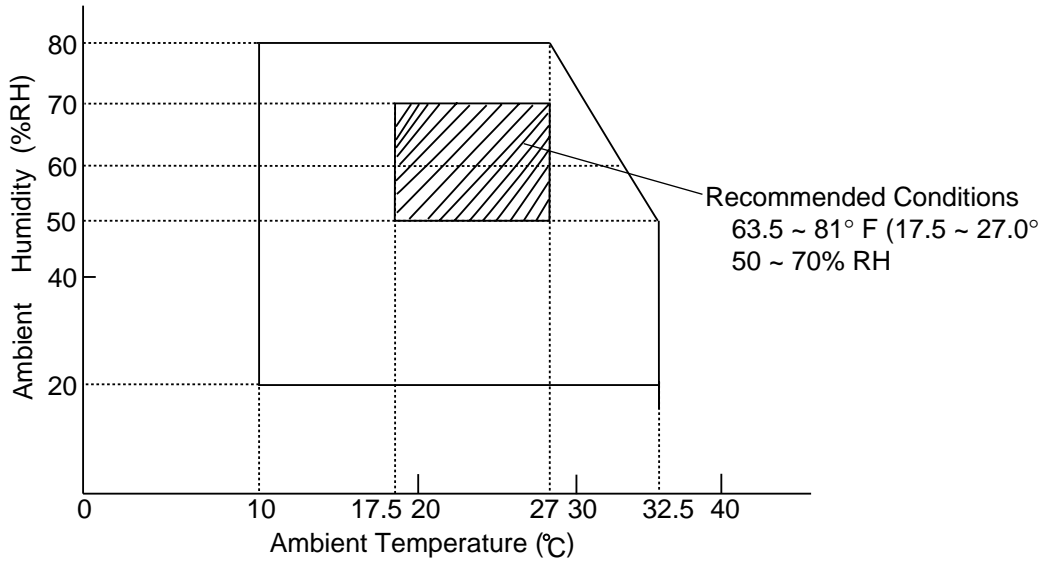

2.3.1.2 Idle: 41~95°F (5.0~35.0°C), 10 ~ 80% RH
(See the figure below.)

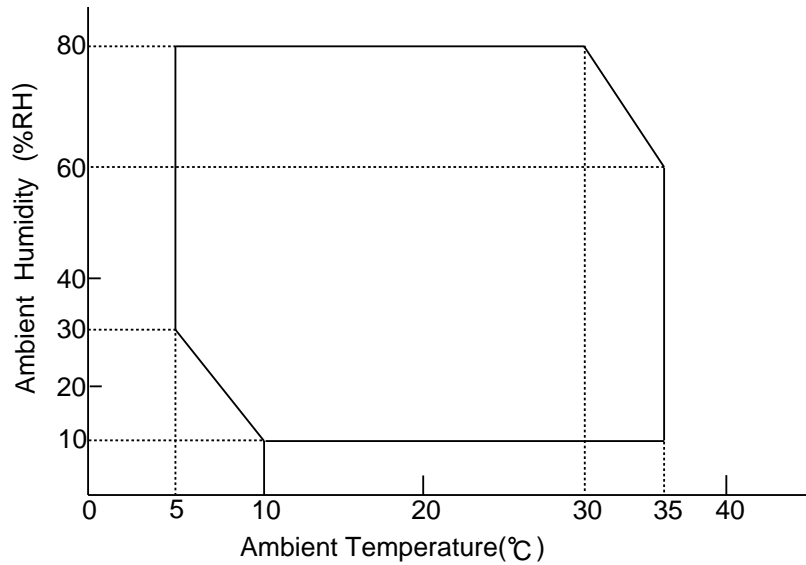

2.3.1.3 Storage and Transportation Environment of Printer

The following defines storage and transportation environment specifications for printers that have been packed according to the OEM manufacturer's specifications. However, this section does not address belt cartridges and toner cartridges. Consumables such as toner are individually packaged. The following guidelines should be followed. During transportation, strictly refrain from leaving the printer and consumables on the ground, in extreme heat, or in direct sunlight.

Description	Parameters
Temperature, Normal Conditions	32°F ~ 95°F (0°C ~ 35°C)
Severe Conditions, High Temperature	95°F ~ 104°F (35°C ~ 40°C)
Severe Conditions, Low Temperature	14°F ~ 32°F (-10°C ~ 0°C)
Humidity	10% ~ 90%RH
Period of Storage	One Year
Other	No Condensation
Atmosphere	613 ~ 1,067 hpa (460 ~ 800 mm Hg)

Notes:

The length of time the printer is exposed to the noted severe conditions must not exceed 48 hours.

The printer must be stored under normal conditions for 90 percent of the storage period. Severe conditions must make up 10 percent of total storage time.

Section 3:
Installation

3.0 Installation

3.1 Conditions for Installation

A laser beam printer will be influenced by its environment. If the printer is set up in an inappropriate location, it may not perform as expected. Therefore, the following factors must be taken into consideration prior to deciding where to set up the printer.

3.1.1 Environmental Conditions

The printer should not be set up in the locations referred to by the following items.

- Exposed to direct sunlight or similar light.
- Areas prone to wide fluctuations in temperature and humidity between the maximum and minimum levels. Normal operation environment is within 50° ~ 95° F (10° C ~ 35° C), 20 ~ 80% RH and without any condensation.
- Areas prone to receive cold air from an air conditioner or warm air from a heater, or to receive direct radiant heat.
- Areas with high levels of humidity, dust, smoke, oil mist, or ammonia gas.
- Areas with poor ventilation.
- Unstable surfaces (table, etc.).
- Unlevel/uneven surfaces (greater than $\pm 1^\circ$).

CAUTION

If the printer is installed on a table, make sure that the paper cassette does not protrude beyond the table edge. Protrusion of the paper cassette may cause the printer to tip over if the user leans against, or applies excessive force to, the paper cassette. Fig. 3-1 shows the basic layout of the printer set up location suitable for the smooth operation and maintenance of printer.

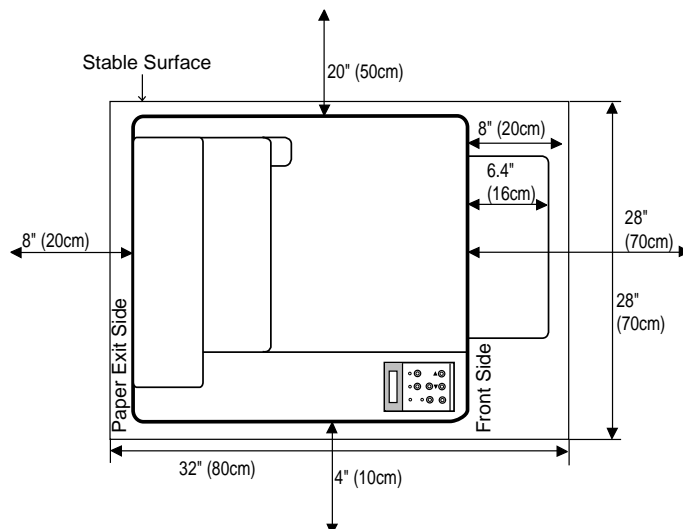

Fig. 3-1

3.2 Unpacking

WARNING

The shipping package is too heavy for one person to carry (143.2 lbs./65 kg). At least two adults are needed to move the printer. Because this printer is a precision machine, carry it carefully, making sure not to bump or jar it excessively.

Do not attempt to lift the printer by the vinyl bag. The bag is not designed to hold the weight of the printer. Additionally, the bag is very slippery and if you drop the printer it will be damaged.

3.2.1 Printer Unpacking Procedures (see Fig. 3-2)

1. Cut two bands (**17**) around the packing box.
2. Remove the tape (**16**).
3. Open the upper flap and pull the outer box (**1**) straight up.
4. Remove the starter kit (**6**).
5. Remove the upper packing (**3**) from the four noted locations.
6. Remove the power cord (**18**).
7. Remove the vinyl bag (**5**) wrapping the printer.
8. Using at least two people, lift and position the printer on a stable surface.

No.	NAME OF PARTS	Q.TY
1	OUTER BOX	1
2	BASE	1
3	UPPER PACKING	4
4	SILICA GEL	1
5	VINYL BAG (EN)	1
6	VINYL BAG (ST)	1
7	STARTER PACKING SLEEVE	1
8	STARTER KIT PACKING (U)	1
9	STARTER KIT PACKING (M)	1
10	STARTER KIT PACKING (L)	1
11	VINYL BAG (CASET)	1
12	VINYL BAG (T)	4
13	VINYL BAG (OPC)	1
14	VINYL BAG (CL)	1
15	VINYL BAG (OIL)	1
16	TAPE	1
17	BAND	2
18	POWER CORD	1

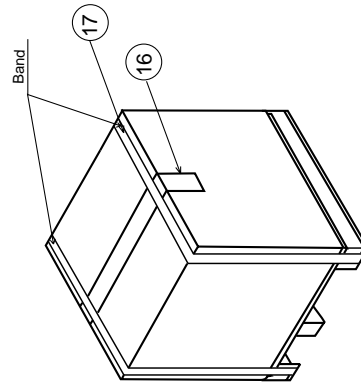
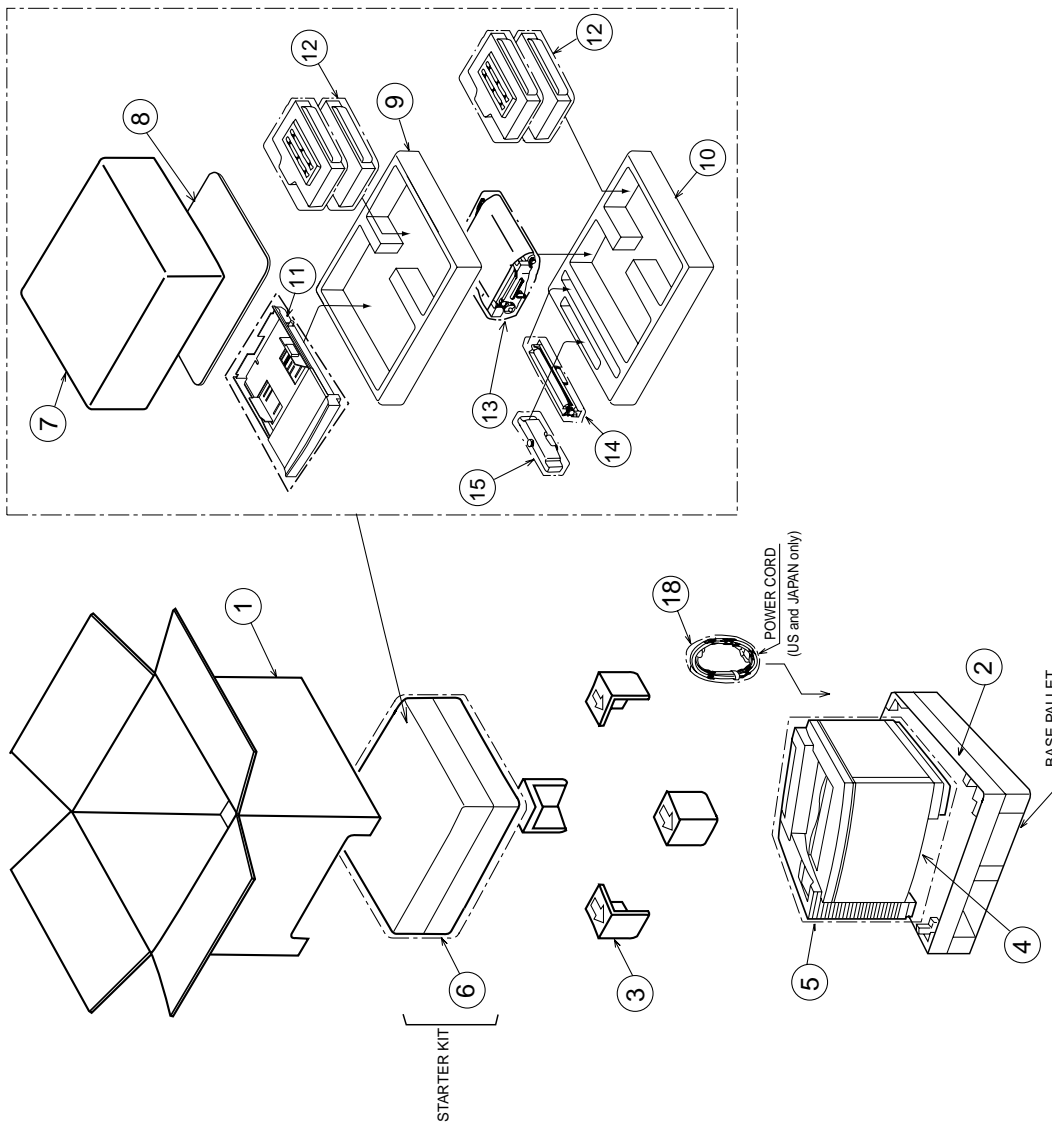
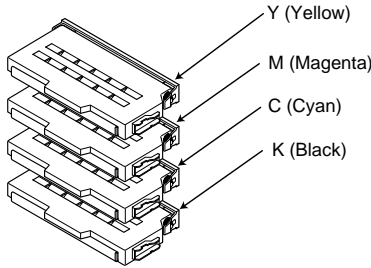
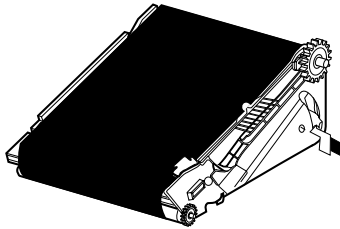
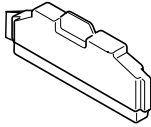
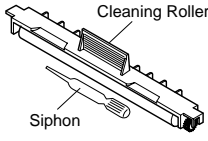
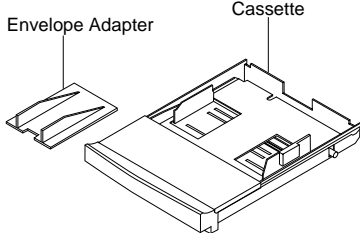

Fig. 3-2

3.2.2 Starter Kit Unpacking Procedures
 (see Fig. 3-2)

1. Open the vinyl bag covering the starter kit (6).
2. Confirm that all of the following items are contained in the starter kit packing box.

Component Name	Diagram
Toner Cartridges Yellow Magenta Cyan Black	
OPC Belt Cartridge	
Oil Bottle	
Cleaning Roller	
Paper Cassette with Envelope Adapter	

3.2.3 Lower Feed Unit Unpacking Procedures

1. Remove the tape from the top of the carton.
2. Open the box (as shown in Fig. 3-3).
3. Take out the side covers right (5) and left (6).
4. Remove the upper packing material.
5. Take out all lower feeder unit components.

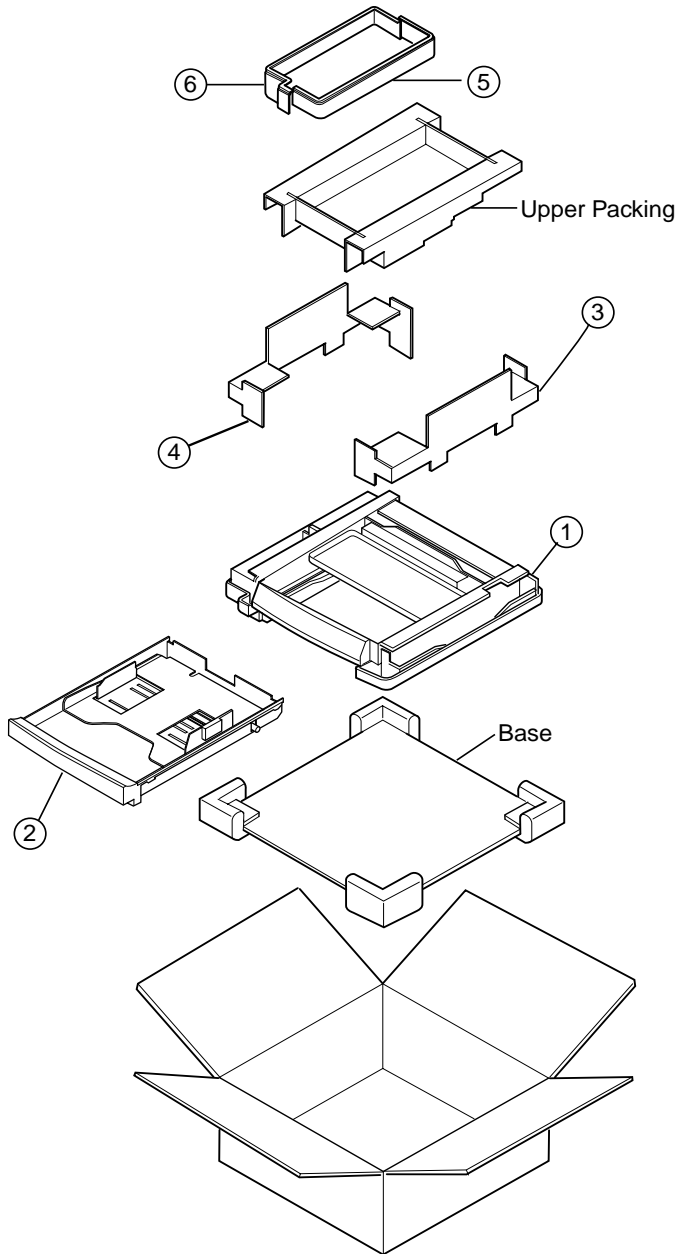

Packing List

No.	Name of Parts	Quantity
1	Lower Feeder Unit	1
2	Paper Cassette	1
3	Set-Up Guide (R)	1
4	Set-Up Guide (L)	1
5	Right Side Cover	1
6	Left Side Cover	1

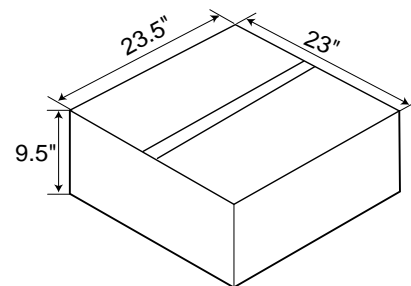

Fig. 3-3

3.2.4 Unpacking the Duplexer

1. Remove the tape from the top of the box.
2. Open the top of the box.
3. Remove the upper packing.
4. Remove the duplex unit.
5. Remove the vinyl bag.

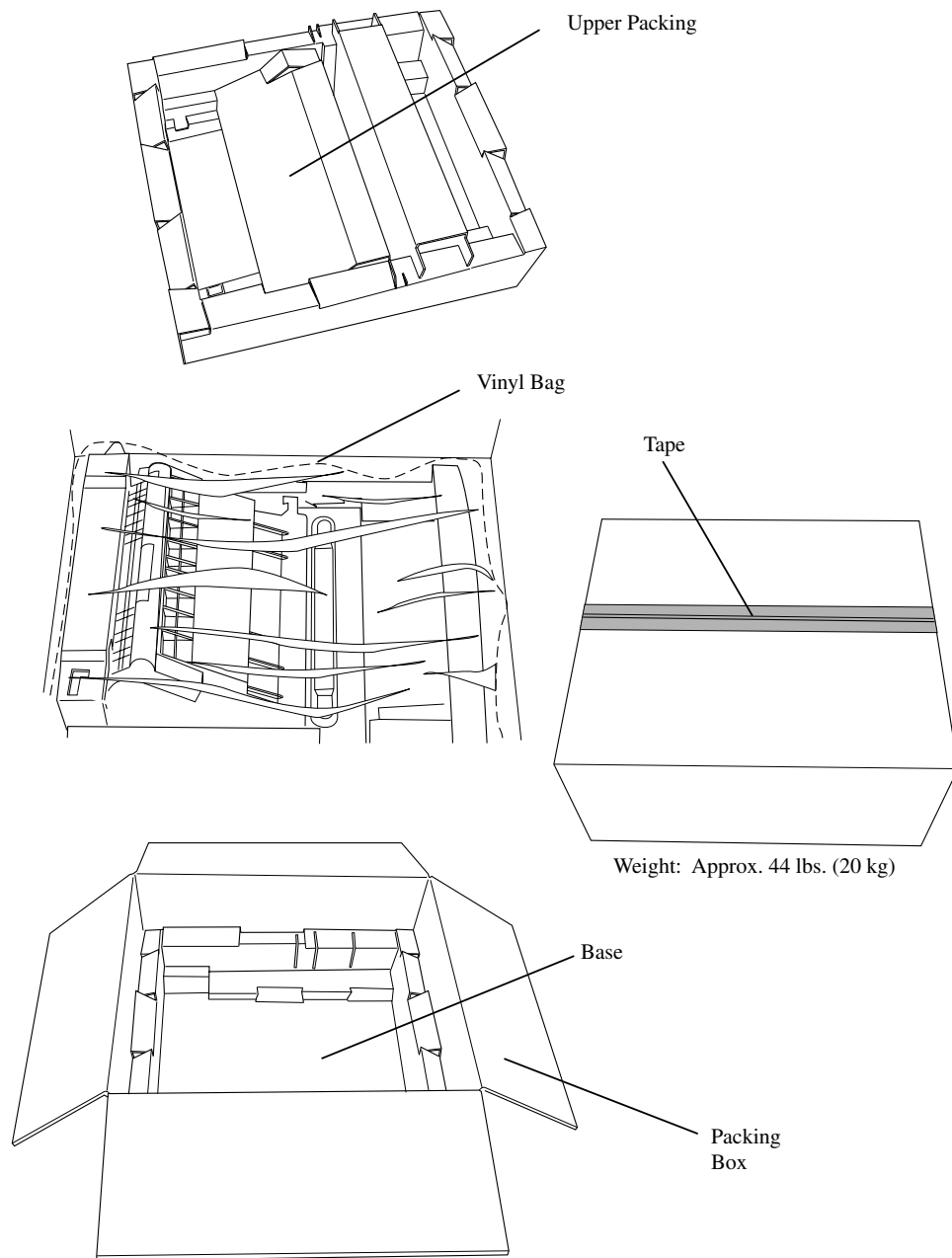

Fig. 3-4

3.3 Installation

Note:

Install the unit parts of the starter kit to the printer according to the following procedures:

3.3.1 Procedures for Installation of Cleaning Roller and Oil Bottle (see Fig. 3-5 to Fig. 3-8).

Note: If a duplexer is installed, open the top cover of the duplexer first.

1. Open the paper exit unit.

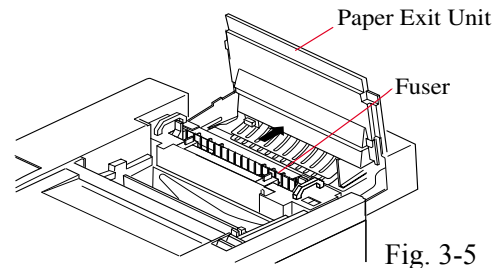

2. Open the oil bottle and cleaning roller lock levers. Move the tension-release levers (left and right) to the normal operating position (center).

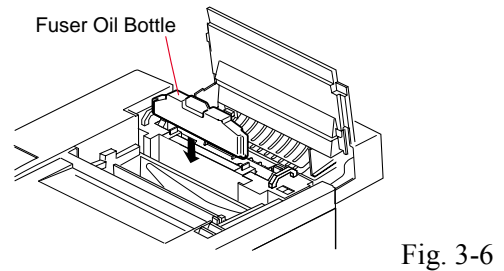

3. Install the oil bottle into the fusing unit.

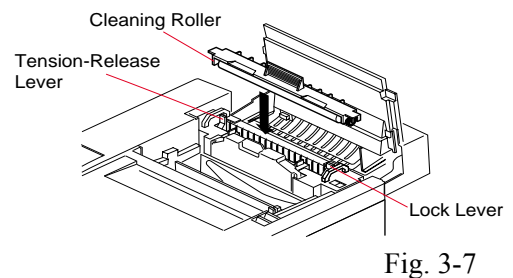

4. Close the retainer lock lever.
5. Install the cleaning roller in the fusing unit.
6. Close the cleaning roller retainer lock lever.
7. Close the paper exit unit.

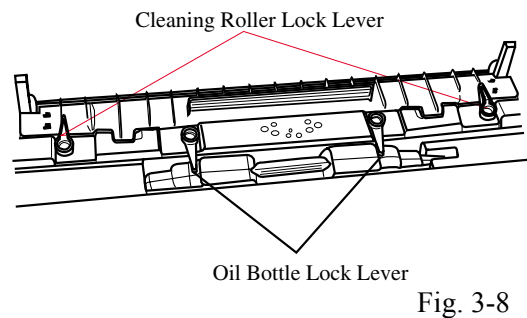

3.3.2 Procedures for Installation of the OPC Belt Cartridge
(see Fig. 3-9 to Fig. 3-12)

CAUTION

Do not touch the OPC belt. Do not expose the OPC belt to direct light because the belt may be ruined.

1. Open the front cover.
2. Open the paper exit unit.

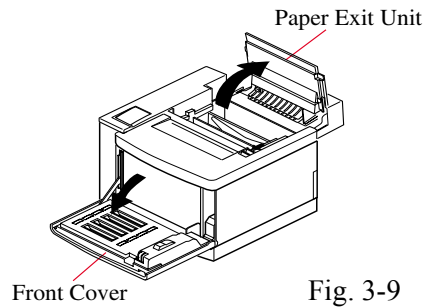

Fig. 3-9

3. Open the belt cartridge lock levers.

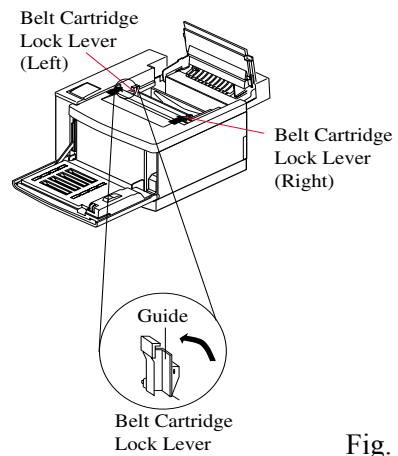

Fig. 3-10

4. Pull and remove the tension release pins from both sides (left and right) from the belt cartridge.
5. Remove the protective sheet from the belt cartridge.

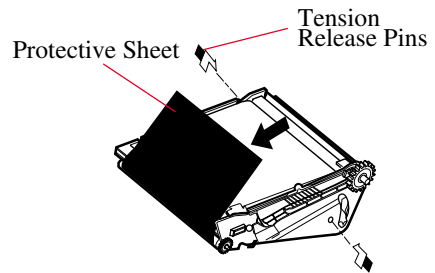

Fig. 3-11

6. Gently slide the new belt cartridge along the guides into the printer.
7. Close the two belt cartridge lock levers.
8. Close the top door.
9. Close the front door.

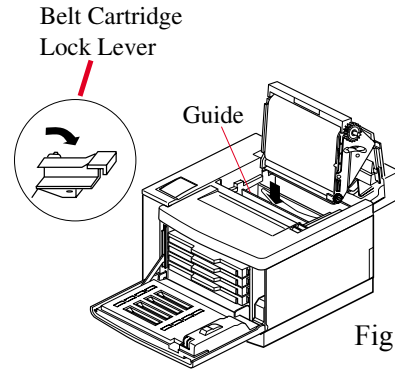

Fig. 3-12

3.3.3 Procedures for installation of the toner cartridges (see Fig. 3-13 to Fig. 3-15)

CAUTION

Holding a toner cartridge vertically will adversely affect the print quality.

1. Open the front door.
2. Holding the toner cartridge horizontally, shake it left and right three to four times.

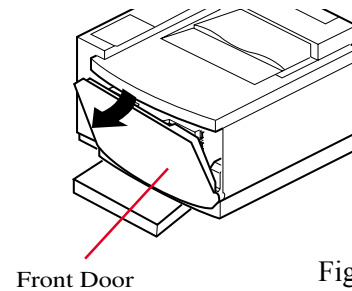

Fig. 3-13

3. Remove the tape from around the protective cover. Remove the protective cover.

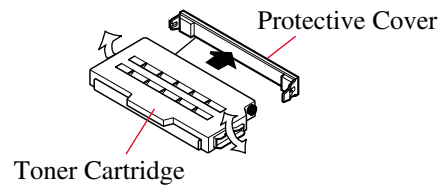

Fig. 3-14

4. Install the toner cartridges in this order: Cyan (C), Magenta (M), Yellow (Y), and Black (K).
5. Push each toner cartridge along the guides into the printer until you feel resistance.
6. Close the front door.

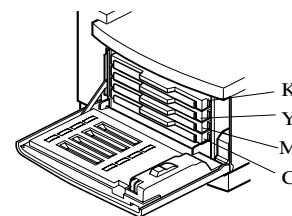

Fig. 3-15

3.3.4 Procedures for installation of paper cassette and adapter
(see Fig. 3-16 to Fig. 3-19).

3.3.4.1 Paper Cassette

1. Remove the cassette cover.

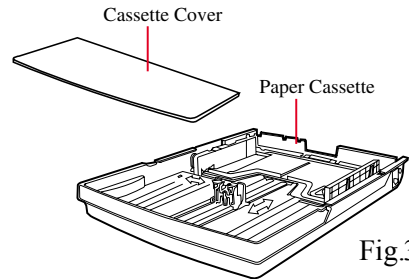

Fig.3-16

2. Set the side plate according to the paper size. For the horizontal direction, move the green side plate to meet the paper size position (see Fig. 3-17). For the vertical direction, move the green lever to adjust the end plate to meet the appropriate paper-size position (see Fig. 3-18).

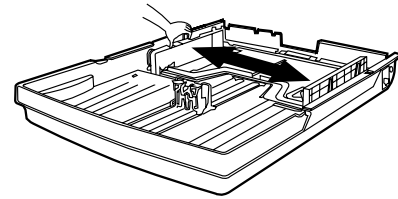

Fig. 3-17

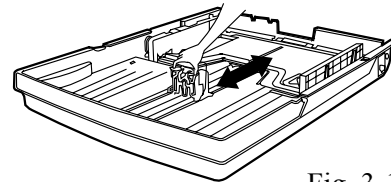

Fig. 3-18

3. Load paper into the cassette.

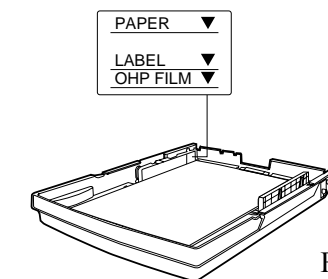

Fig. 3-19

CAUTION

The capacity of the cassette is dependent upon the type of media used. Keep the volume below the upper limit marked on the label. Overloading media will result in paper feed jams or print quality failure.

4. Install the cassette cover and slide the cassette into the printer.

3.3.4.2 Installation procedures for the envelope adapter
(see Fig. 3-20 to Fig. 3-21)

3.3.4.2.1 Specifications of adapter.

	Envelope	Optional Post Card
Capacity	15 (7 High Humidity)	50
Size	DL, #10	10 x 148 mm

Installation:

1. Put the adapter on the cassette base, and latch the hook onto the cassette base.
2. Move the side plate to meet the adapter base.
3. Move the end plate to the desired envelope size. If you have a post-card adapter, move the end plate until it contacts the adapter base.
4. Move the adapter plates to meet the desired envelope size.

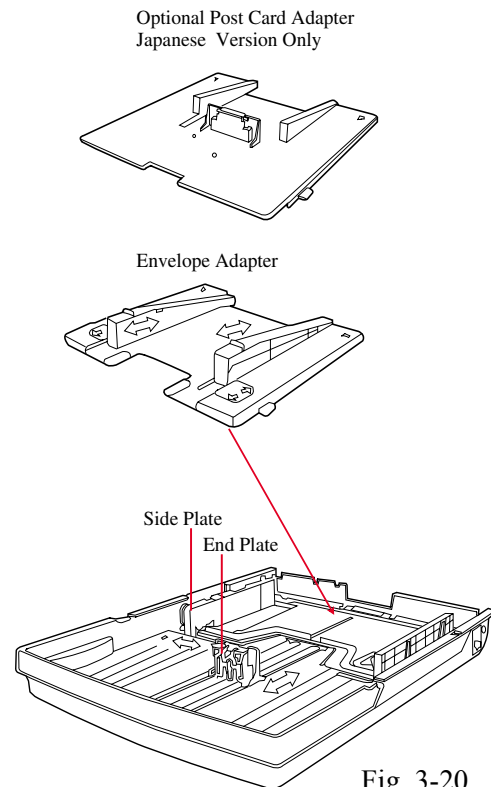

Fig. 3-20

CAUTION

Do not load the media in the adapter above the specified capacity limit. It may result in a paper feed jam or bad print quality.

5. Load the envelopes in the adapter.
6. Slide the paper cassette into the printer.

3.3.4.3 Procedures for removal of the envelope adapter:

1. Remove the paper cassette from the printer.
2. Move the end and side plates out to release the adapter.
3. Lift up the trailing edge of the adapter approximately 10 mm and pull the adapter toward you.
4. Remove the adapter.

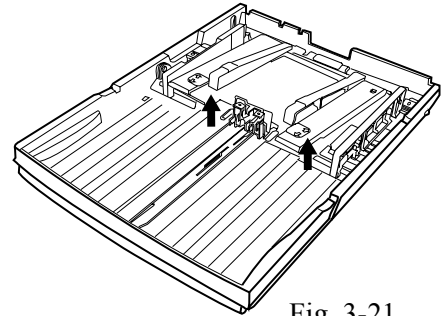

Fig. 3-21

CAUTION

Do not lift up the trailing edge of the envelope adapter forcefully, otherwise, it may result in damaging the hook at the leading edge of the adapter.

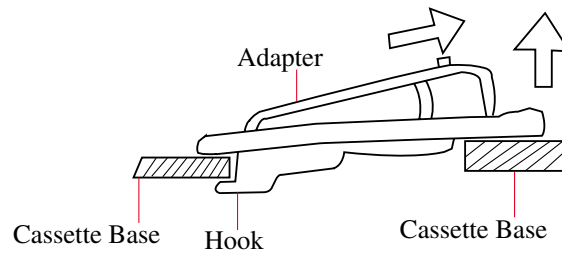

Fig. 3-22

3.3.5 LFU Installation

1. Lay the Lower Feeder Unit (LFU) on a flat and stable surface. Adjust the anchor feet all the way up.

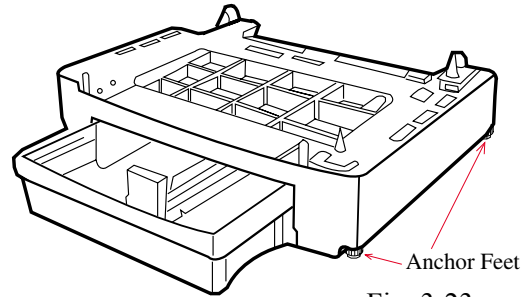
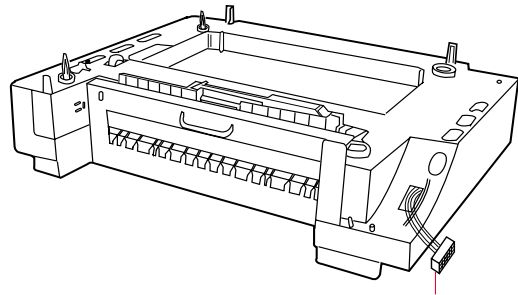

Fig. 3-23

2. Pull out the LFU connector cable from the rear left of LFU.



LFU Cable
Fig. 3-24

3. Orient the LFU and the position of the adjuster pins. Verify the position of the claw of the tray latch (see Fig. 3-25).

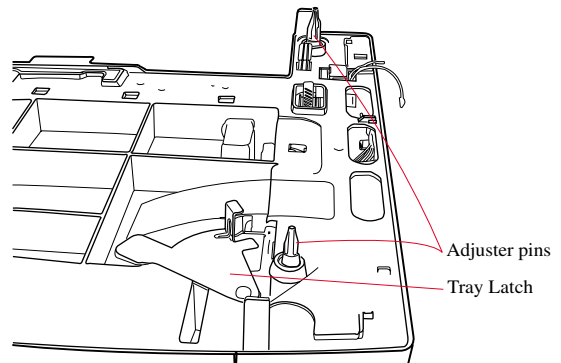

Fig. 3-25

CAUTION

The printer weighs approximately 143.2 lbs. (65kg) which is too heavy for one person to carry. At least two adults are needed to move the printer. Because this printer is a precision machine, carry it carefully, making sure not to bump or jar it excessively.

4. Lift up the printer with assistance, and mount it on the LFU.
 - A. Slowly lower the printer so its bottom hole meets the adjuster pin of the LFU.
 - B. After placing the printer on the LFU, confirm that all parts meet properly.

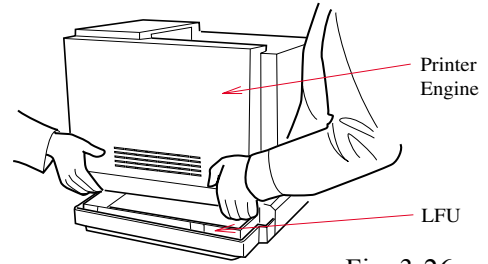

Fig. 3-26

5. Couple the printer with the LFU.
 - A. The metal coupler is fixed to the rear left area by a thumbscrew (see Fig. 3-27).
 - B. Loosen the thumbscrew, and hook the leading edge of metal coupler onto the engine base (see Fig. 3-27).
 - C. Tighten the thumbscrew to secure the metal coupler.

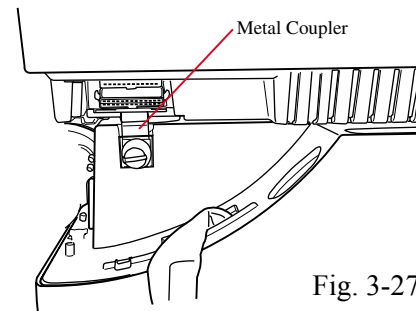

Fig. 3-27

- D. Look into the entrance of the cassette slot for the tray latch at the right front side of the LFU. The tray latch can be pivoted on its set screw.

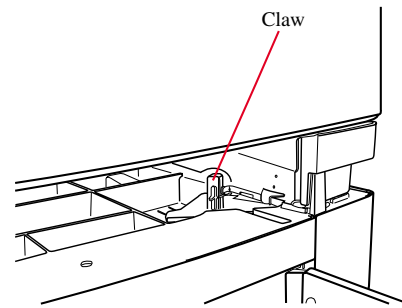

Fig. 3-28

- E. Pivot the tray latch so that it is hooked to the engine base.

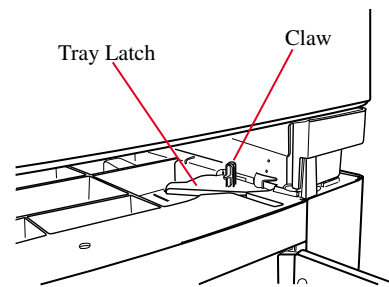

Fig. 3-29

6. Connect the LFU interface cable to the printer connection.

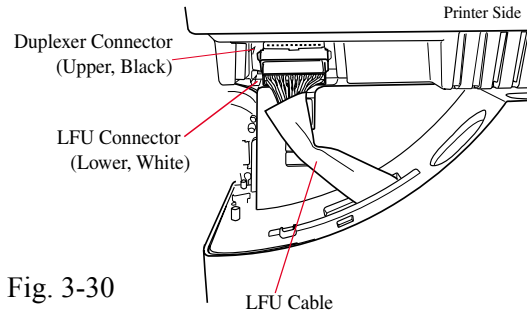

Fig. 3-30

7. Install the right side cover. Pop in the right side cover (back to front); no mounting hardware is necessary.

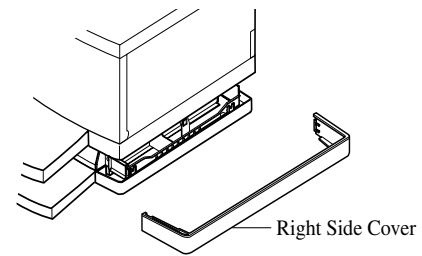
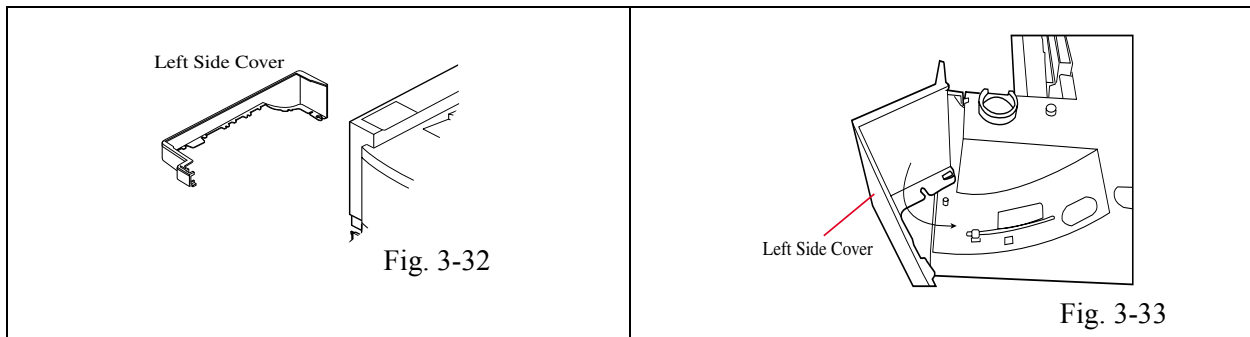

Fig. 3-31

8. Install the left side cover. Pop in the left side cover; no mounting hardware is necessary.



9. Adjust the anchor feet for stability. Rotate each anchor foot to move it down, and stop the adjustment when the anchor foot reaches the level surface.
10. Turn the locking nut upward and fix the anchor bolt.

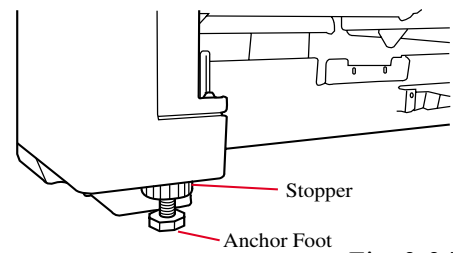

Fig. 3-34

CAUTION

When lifting the printer, make sure that the connector of the LFU connector cable and tray latch are disconnected before lifting.

3.3.6 Installation of the Duplex Unit

3.3.6.1 Preparation of the Printer and Lower Feed Unit

1. Assemble the lower feeder unit on the printer. See the installation instructions for the lower feeder unit (see section 3.3.5).

3.3.6.2 Preparation of the Printer

1. Remove the paper exit upper cover (see Fig. 3-35).
2. Remove the two caps from the upper rear cover (see Fig. 3-36).
3. Remove left and right LFU side covers (see Fig. 3-37 and Fig. 3-38).
4. Remove the LFU left and right access plates (Fig. 3-39 and Fig. 3-40).

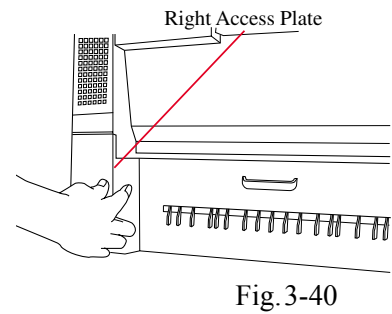
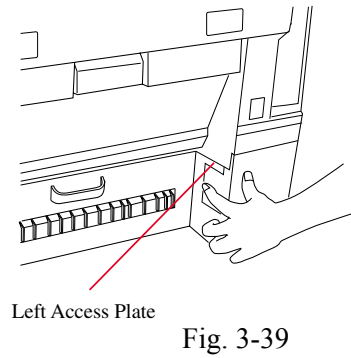
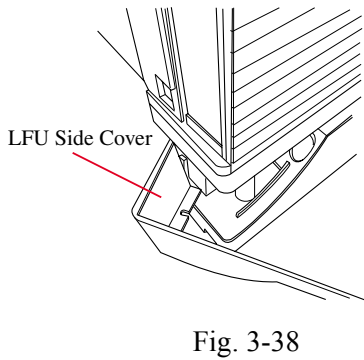
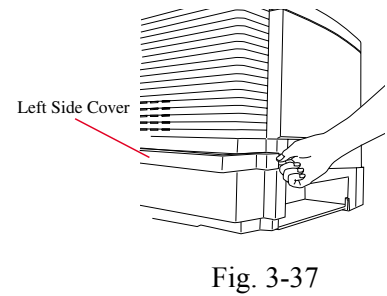
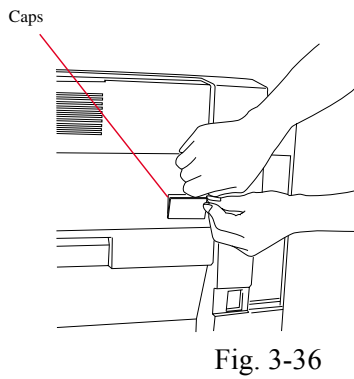
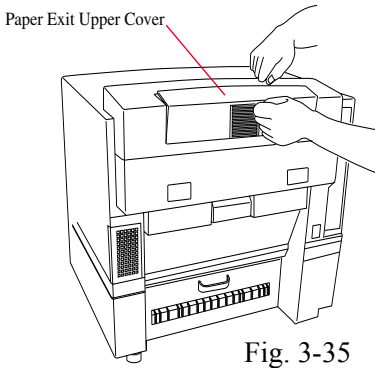

3.3.6.3 Installation of Duplex Unit.

CAUTION

Confirm that the jam cover of LFU is securely closed (see Fig. 3-41).

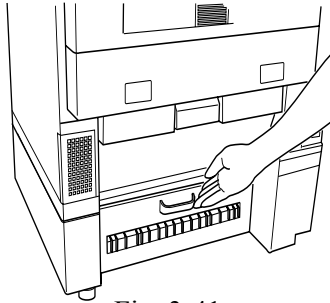

Fig. 3-41

1. While holding the handle, lift up the duplex unit (see Fig. 3-42).

CAUTION

Pay attention to the duplex top cover because it may be folded in the middle. Pay attention not to get your fingers caught between the hinges of the upper and lower unit.

2. Insert the fixing pins into the sockets of the LFU (see Fig. 3-43 and Fig. 3-44).

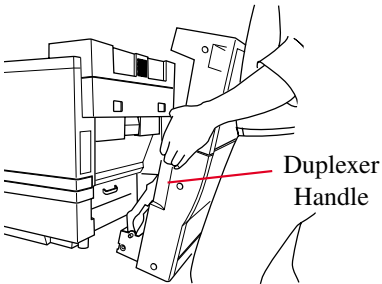

Fig. 3-42

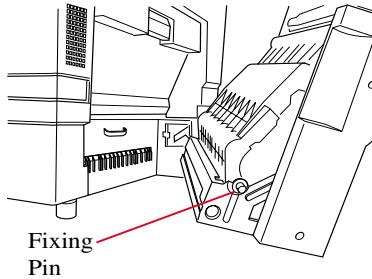

Fig. 3-43

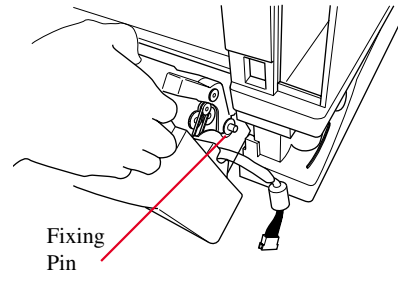

Fig. 3-44

3. Attach the hooks (located on each side of the DPU) to the holes of the printer. Install the duplexer (see Fig. 3-44).

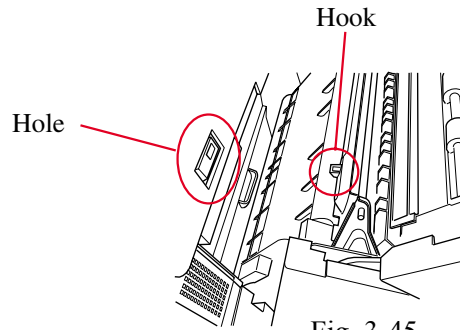

Fig. 3-45

4. Slowly open the upper unit.
5. Secure the duplexer to the printer with the thumb screws (see Fig. 3-46).

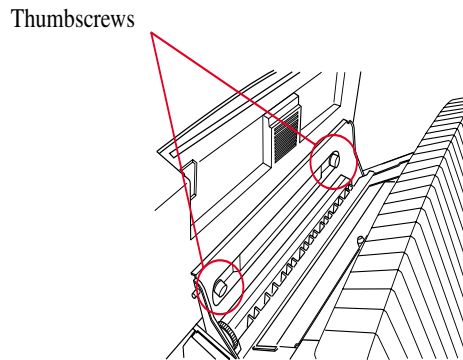

Fig. 3-46

6. Close the upper unit.
7. Connect the interface connectors between the DPU and the printer (see Fig. 3-47 and Fig. 3-48).

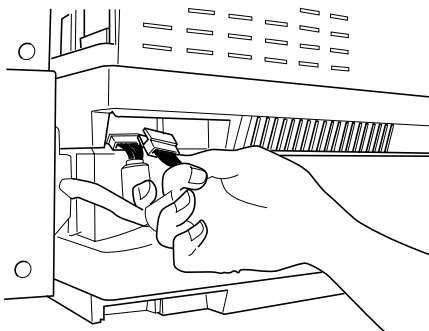

Fig. 3-47

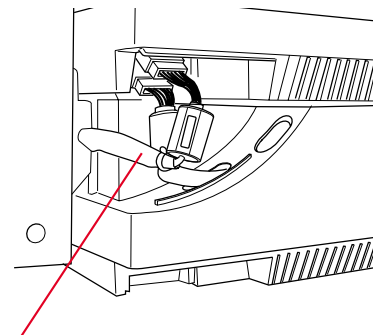

Fig. 3-48

8. Install the LFU left side cover
(see Fig. 3-49).

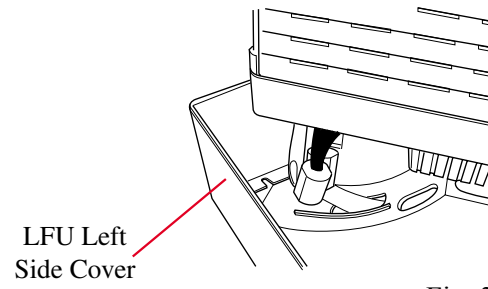
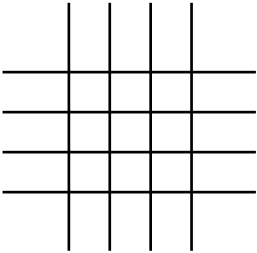
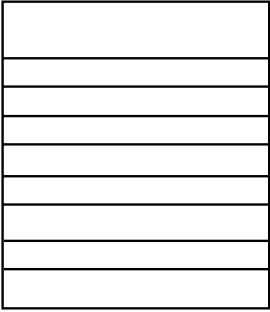

Fig. 3-49

3.3.7 Test Run and Test Print

3.3.7.1 Test Print

3.3.7.1.1 Test Print Details

Operation	Details of Operation
<p>Test Print See section 3.3.7.1.2 “Test Print Procedures” for details.</p>	<p>Printer has the following built-in print patterns for test printing.</p> <p>1). Grid Pattern: Available in mono-color print of Y, M, C, K, and two-color print of R, G, and/or B.</p> <div data-bbox="768 785 1127 1035"><p style="text-align: right;">GRID</p></div> <p>2). Stripe Pattern: Available in color print of Y, M, C, K, R, G, and B.</p> <div data-bbox="776 1224 1143 1533"><p style="text-align: right;">STRIPE</p></div>

3.3.7.1.2 Test Print Procedures

Perform the test print according to the following procedures.

<u>Procedure</u>	<u>Operator Panel</u>
1. Turn off the printer. Holding down both scroll keys (Left and Right) and the MENU Key, turn on the printer.	A) SERVICE MODE ▷ TEST PRINT / NEXT
2. Press the SELECT key so that the display changes from screen A) to B).	B) 31 GRID PRT ▷ GRID / STRIPE
3. Select “GRID” with the SCROLL keys. Note that you could select the option of printing a “STRIPE” here.	C) 31 GRID PRT ▷ Y / M / C / K / R / G / B
4. Press the SELECT key so that the display changes from screen B) to screen C).	D) 31 GRID PRT DUP ▷ 1 / 2 / 3 / SIMP
5. Select the color “R” (red) with the SCROLL keys. Note that you could select the option of printing yellow, magenta, cyan, black, red, green, or blue here.	E) 31 GRID PRT YM
6. Press the SELECT key so that the display changes from screen C) to screen D). This screen will only appear when the optional duplexer is attached.	F) MEDIA KEY
7. Press the SELECT key so that the display changes from screen D) to screen E).	
8. Press the MEDIA key to stop the test print.	
9. Repower the printer to bring it back to normal printing mode.	

3.3.7.1.3 Selection of Media

Press the MEDIA key on the operator panel, which selects the media to be used. Select the tray which will hold the media.

3.3.7.1.4 Operator Call

When “Operator Call” is displayed on the operator panel, see the “Operator Call” information in section 8.2.1, and take the necessary actions.

Section 4:
Theory of Operation

4.0 Theory of Operation

4.1 Basic Structure

4.1.1 Mechanical and Electrical Structures

This laser beam printer consists of five individual systems including: Print, Optical, Transfer, Paper Transport, and Control. See Fig. 4-1 for the sequence of operations.

4.1.1.1 Print System

Print system consists of the following six functional subsystems located around the OPC Belt, which form a toner image on the OPC Belt.

- Charge
- Expose
- Development
- First Transfer
- Discharge
- Clean

4.1.1.2 Optical System

The optical system consists of the following two functional subsystems. The optical system forms an electrostatic latent images on the OPC belt by scanning the OPC belt with a laser beam.

- Optical Unit
- Scanner Motor (SCM)

4.1.1.3 Transfer System

The transfer system consists of the following three functional subsystems, which transfer the toner image formed on the transfer drum to the paper.

- Transfer Drum
- Second Transfer
- Drum Cleaner

4.1.1.4 Paper Transport System

The paper transport system consists of the following five functional subsystems, which pick up a page from the paper cassette, separate the paper from the transfer drum, and feed it from the printer after fusing the toner image on the transported paper.

- Paper Cassette
- Transport
- Paper Discharger
- Fuser
- Paper Exit

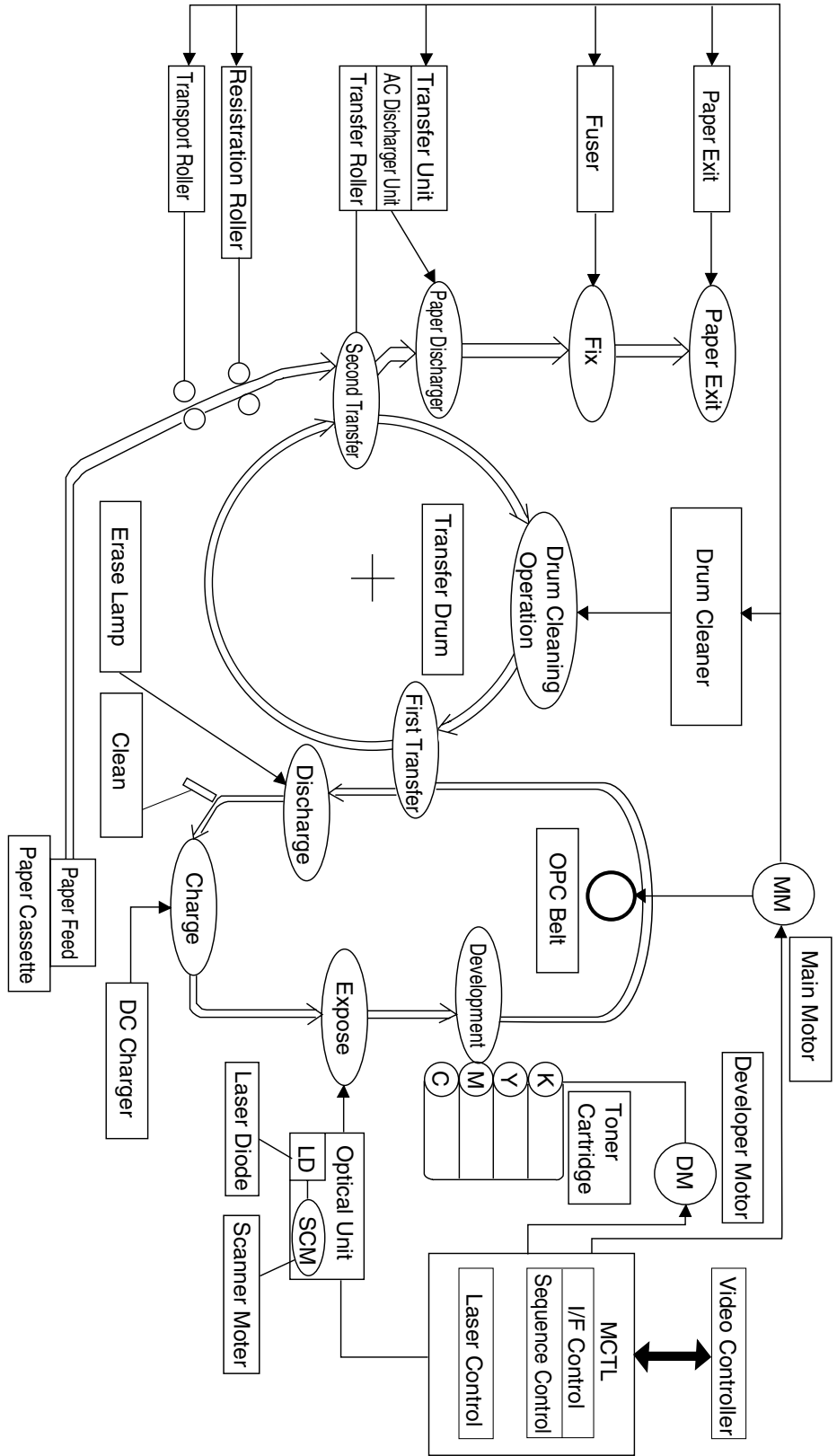

Fig. 4-1

4.1.1.5 Control System

The control system consists of the following four control logic functions which run the printer by processing the interface signals transmitted from the host and each subsystem such as the print, transfer, optical, transport system.

- Sequence Control
- Laser Control
- Fusing Temperature Control
- Interface Control

4.1.2 Basic Mechanism of Color Printing

4.1.2.1 Principle of Color Printing

Color printing uses the subtractive color theory process by combining three primary colors, yellow, magenta, and cyan (Fig. 4-2 shows the three primary colors and subtractive process).

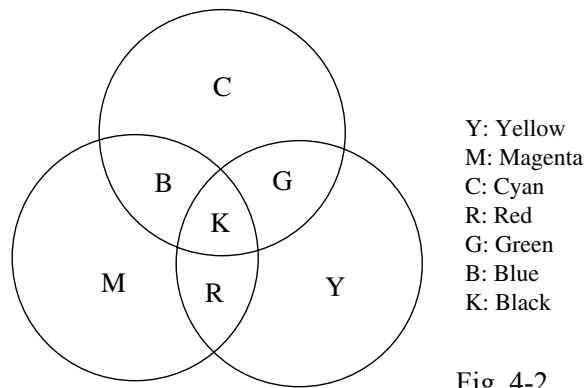

Fig. 4-2

4.1.2.2 Basic Process of Color Printing

- The printer has a yellow, magenta, cyan, and black toner cartridge (see Fig. 4-3).
- The toner image is developed by cyan, yellow, and magenta toner. Combinations of toner, moved to the transfer drum, develops different colors (see Fig. 4-4).

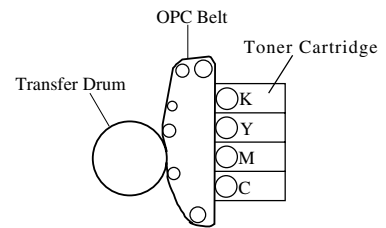

Fig. 4-3

- The toner image formed on the transfer drum is transferred to paper (see Fig. 4-4).
- The toner is fused to the paper by the fuser unit. This process fixes the toner image onto the paper (see Fig. 4-4).

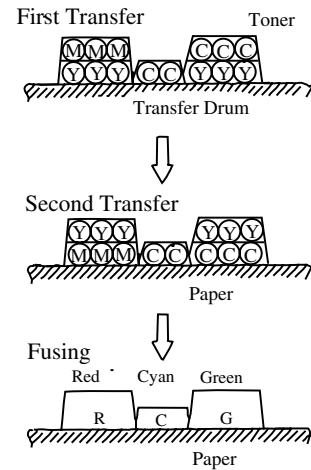

Fig. 4-4

4.1.3 Structure of the OPC Belt

The OPC belt consists of a surface layer of photoconductor OPC/organic material, an inner layer of an insulator material (PET), and the aluminum deposit layer in between (see Fig. 4-5). The OPC belt is a main part of the print system (see Fig. 4-6).

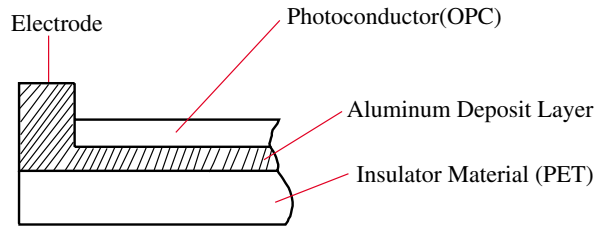

Fig. 4-5

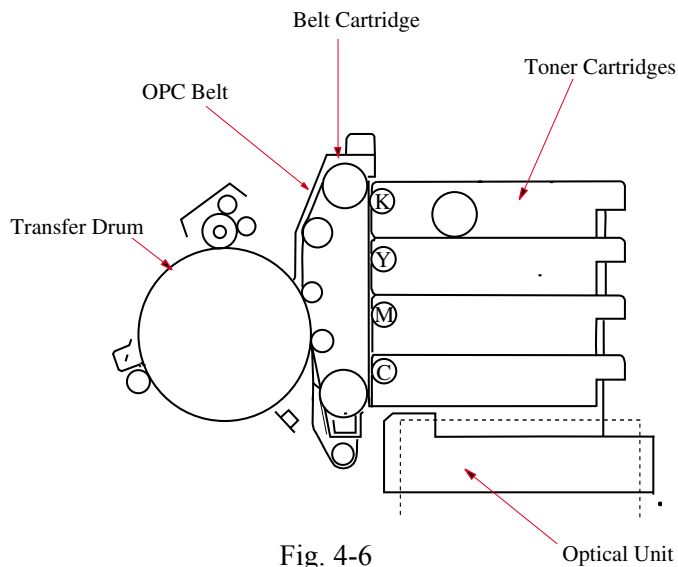

Fig. 4-6

4.2 Print System and Transfer/Transport System

Fig. 4-7 shows the basic systems of the printer.

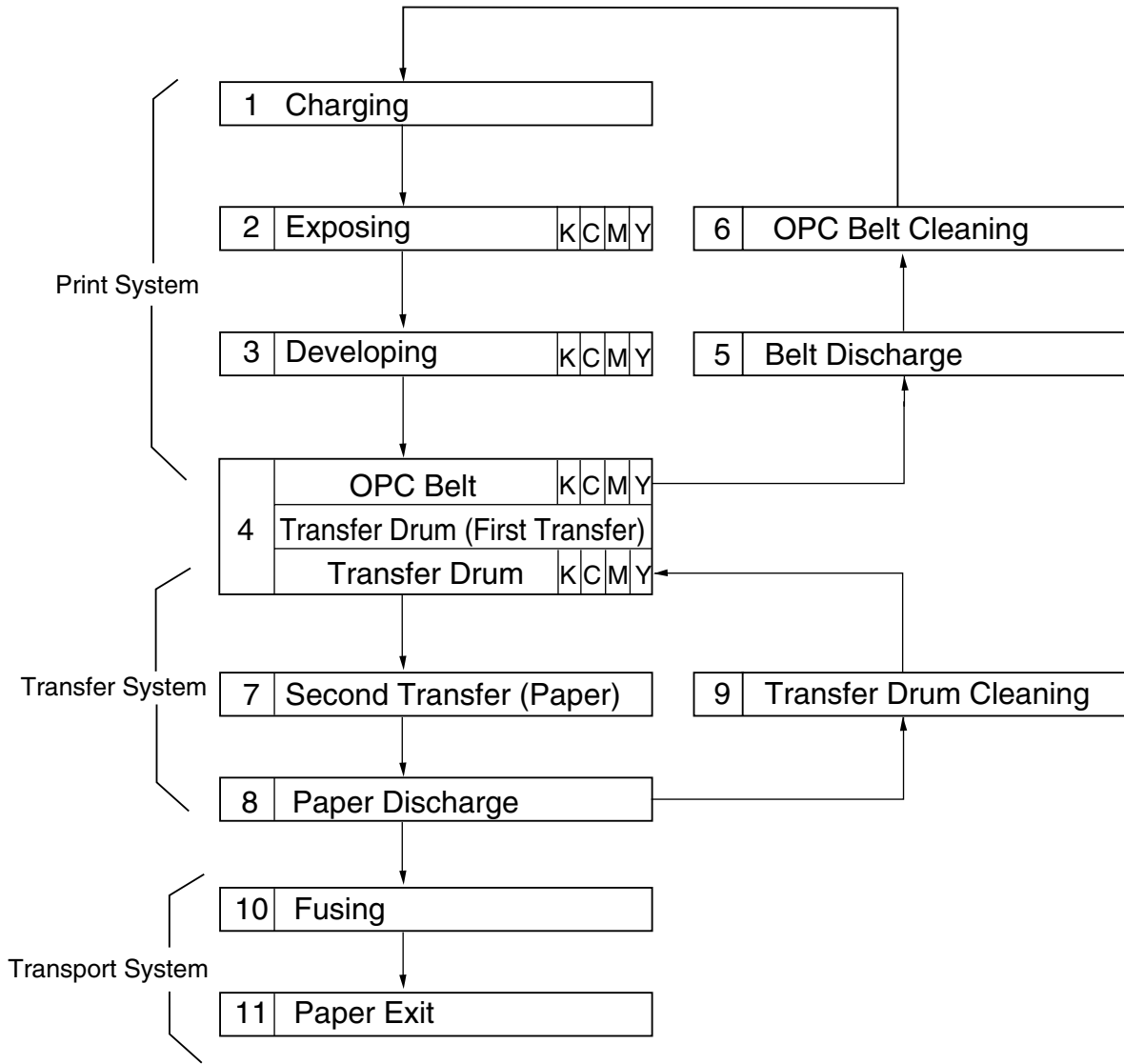

Fig. 4-7

4.2.1 Structure of Printer

<u>Name of Component</u>	<u>Function</u>
Charger	Charges the OPC.
Optical Unit	Exposes the OPC.
Toner Cartridge	Develops the latent image on the OPC.
Belt Cartridge	Receives Latent Images and transfers developed images to the Drum.
Transfer Drum	Transfers Image to Paper.
Belt Discharger Erase Lamp	Discharges the OPC Belt.
Cleaning Blade	Cleans the OPC Belt.
Transfer Roller	Transfers Toner Image to the Paper from the Drum.
Paper Discharger	Separates the Paper from the Drum.
Drum Cleaner	Cleans the Drum.
Fuser Unit	Fuses the Toner to the Paper.
Paper Exit Unit	Ejects Paper into the Paper Exit Tray.

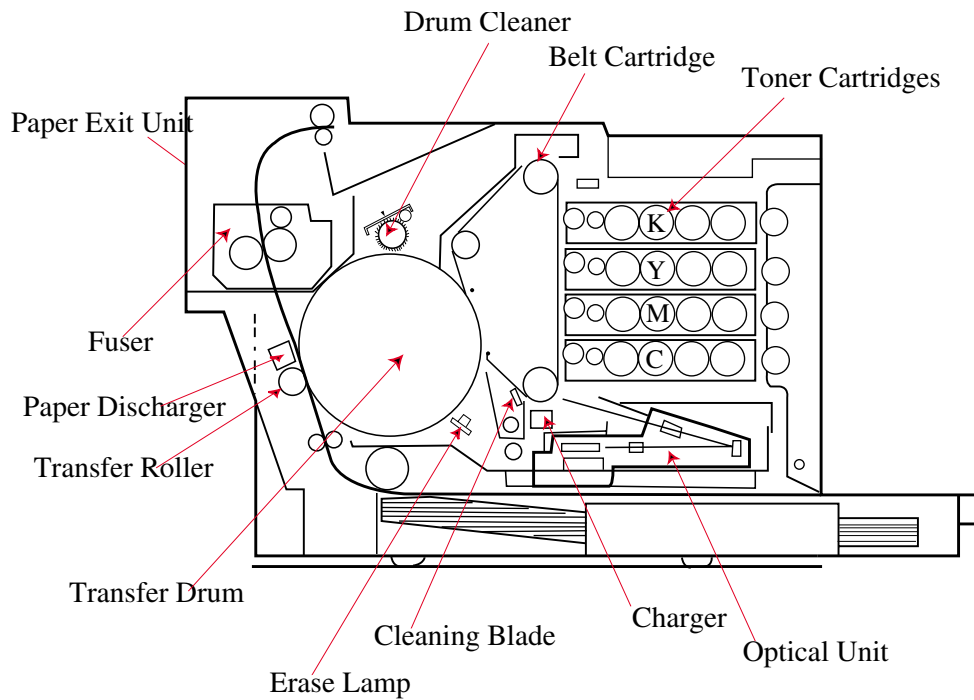

Fig. 4-8

4.2.2 Basic Structure of the Printing System

The toner image is formed by the potential of the OPC belt varying with each of the processes. They are charging, exposing, development, transfer, and cleaning.

4.2.2.1 Processes of the Print System

(see Fig. 4-9)

The OPC belt is biased to the voltage of $-CBV$ by the HVPS (CBV). The negative high voltage is applied to the charger unit by the HVPS (CBV), and an electrostatic charge is generated.

The developer Roller of the toner cartridge is biased to $-DBV$ by the HVPS (DBV). The frame potential of the transfer drum is GND.

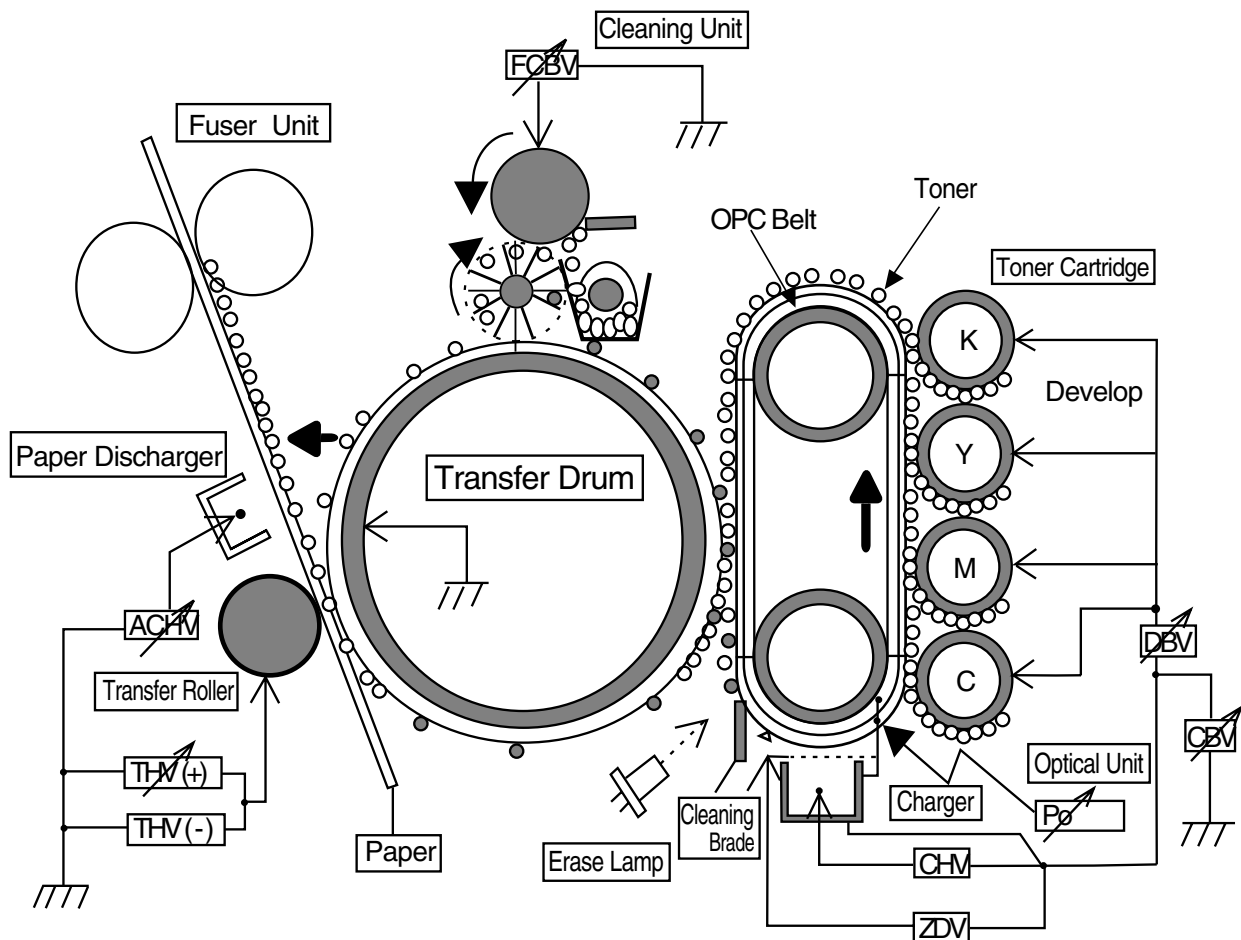

Fig. 4-9

4.2.2.2 Variation of the OPC Belt's Potential
(see Fig. 4-10).

The OPC belt is biased to $-CBV$. The OPC belt's surface is evenly charged to V_0 in the process of charging. The potential of the OPC belt is discharged to $-V_R$ as it is exposed to the laser beam. An electrostatic latent image is formed on the OPC belt.

Negatively charged toner is attracted to the OPC belt in the development process due to the difference of potential between $-V_R$ and $-DBV$, and the visible image is now formed.

Negatively charged toner on the OPC belt is moved to the transfer drum in the transfer process because the potential GND of the transfer drum is greater than $-V_R(V)$ of OPC belt.

The OPC belt is discharged by the erase lamp shining on the OPC belt.

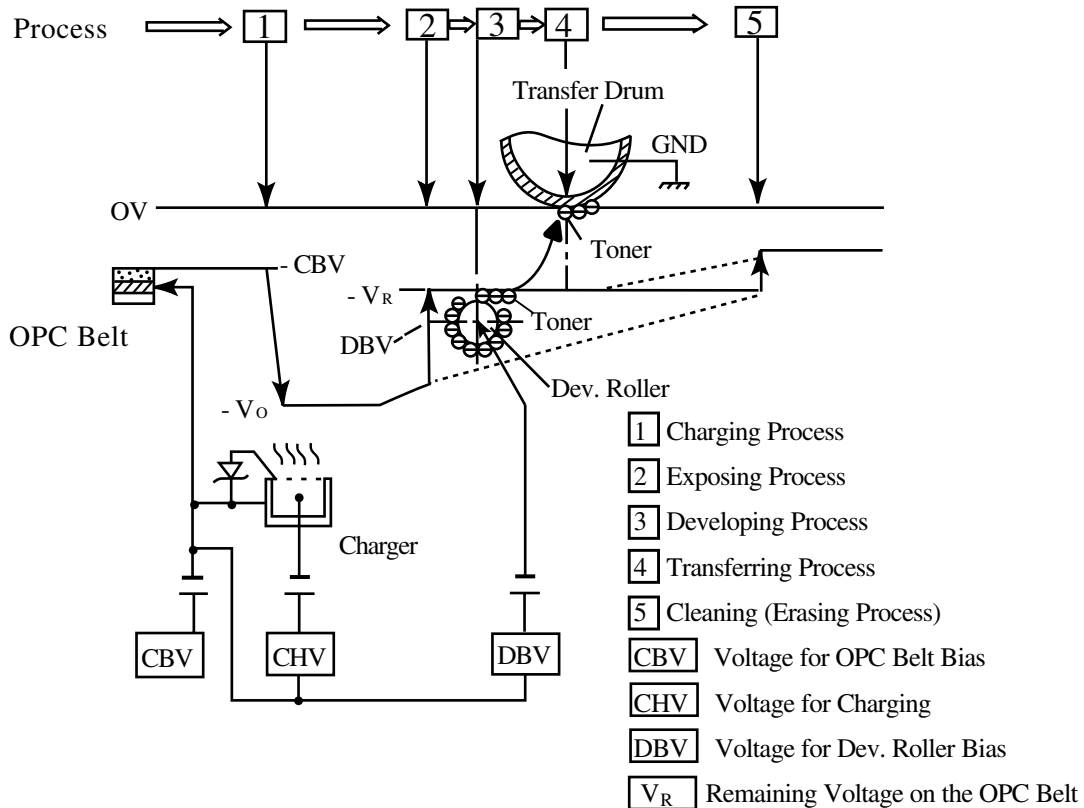

Fig. 4-10

4.2.3 Details of Each Process

4.2.3.1 Charging

The charging process means that the OPC belt is evenly charged by the charger.

4.2.3.1.1 Structure of the Charger Unit (see Fig. 4-11).

The charger unit is located as shown in Fig. 4-11. The charger unit consists of the case, corona wire and grid (see Fig. 4-11). The grid is constructed to allow for uniform charging.

The charger unit charges the OPC belt surface to the potential $-V_0$.

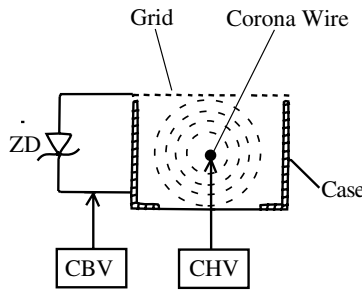

Fig. 4-11

4.2.3.1.2 Process of Charging (see Fig. 4-12)

The OPC belt is biased to $-CBV$. The charger unit generates a negative charge and uniformly charges the surface of the OPC belt.

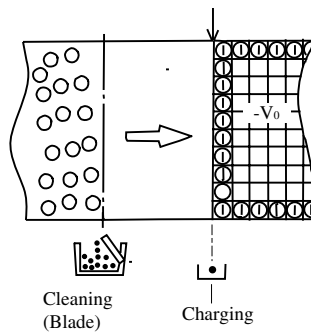

Fig. 4-12

4.2.3.2 Exposing

During the exposing process, the OPC belt surface is exposed by a laser beam, which forms an electrostatic latent image.

4.2.3.2.1 Structure of the Optical Unit

The optical unit is located as shown in Fig. 4-8.

The source of the laser beam is a semiconductor laser. The laser beam is transformed into a beam of light by the optical unit. Scanning over the OPC belt creates an electrostatic latent image.

4.2.3.2.2 Process of Exposing

(see Fig. 4-12)

The OPC belt surface has been charged to the potential $-V_0$.

The laser beam scans across the OPC belt as the belt moves in its forward direction. The image data transmitted from the host switches the laser on and off. The areas exposed to the laser are discharged to the potential of $-V_R$.

An invisible electrostatic latent image is formed on the OPC belt (see Fig. 4-12).

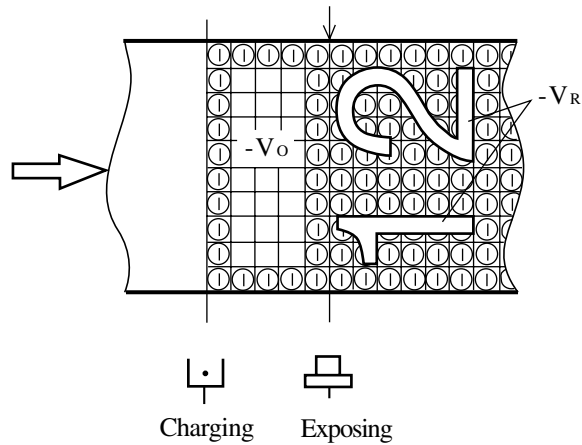

Fig. 4-13

4.2.3.3 Developing

Developing is defined as a process to develop the electrostatic latent images that have been transferred onto the OPC belt by using toner.

4.2.3.3.1 Structure of the Toner Cartridge

(see Fig. 4-8)

Toner cartridge is located as shown in Fig. 4-8.

Four toner cartridges are used. The order of the toner cartridges from top to bottom is black, yellow, magenta and cyan.

4.2.3.3.2 Process of Developing

(see Fig. 4-8, and Fig. 4-14 to Fig. 4-16)

Toner adheres to the developer roller of the toner cartridge. Development occurs when the developer roller contacts the OPC belt surface.

The developer roller has been biased to the potential $-DBV$. Fig. 4-14 shows the relationship established between the potential of the toner, the potential $-V_0$ at the non-exposed area of OPC belt and the potential $-VR$ at the exposed area of OPC belt.

Potential of the exposed area is positive relative to the potential of the toner. Therefore, toner is attracted to the OPC belt, where the development takes place.

Potential of the unexposed area has the same polarity as the toner. Therefore, the toner is repelled by the surface of the OPC belt, where no development takes place.

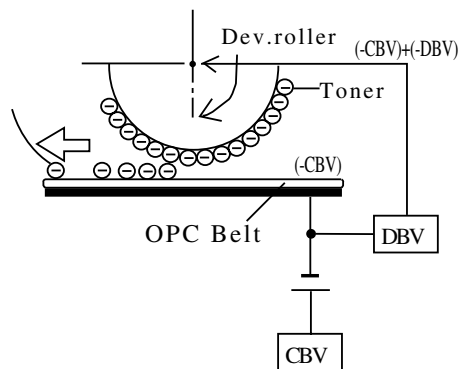

Fig. 4-14

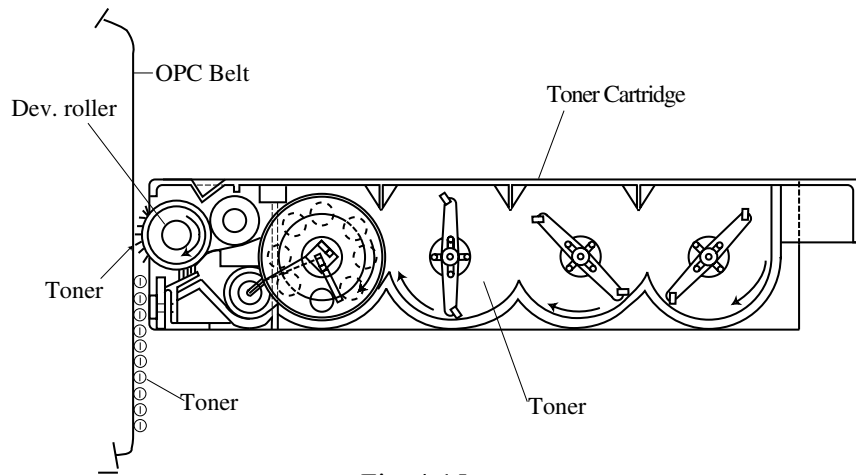

Fig. 4-15

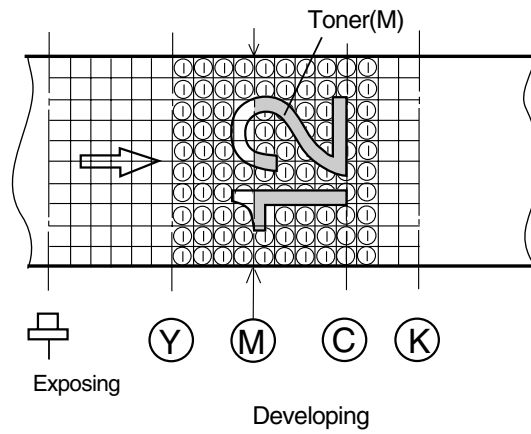

Fig. 4-16

4.2.3.4 First Transfer (Drum)

First transfer is defined as the process which moves the toner images from the OPC belt to the transfer drum.

4.2.3.4.1 Structure of the Drum Transfer

(see Fig. 4-8 and Fig. 4-17)

The drum transfer components are shown in Figure 4.8.

The drum is made of aluminum. The drum surface is coated with rubber as shown in Fig. 4-17. The transfer drum rotates, synchronously maintaining contact with the OPC belt.

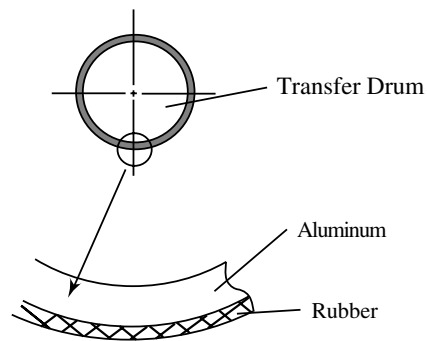

Fig. 4-17

4.2.3.4.2 Process of First Transfer

(see Fig. 4-18)

The OPC belt comes in contact with the transfer drum, and rotates synchronously with the transfer drum. The OPC belt is biased to the potential of -CBV. The potential of the transfer drum is near ground.

The toner on the OPC belt is moved to the transfer drum due to the difference of potential between the OPC belt and the transfer drum. Each color toner is developed and transferred onto the transfer drum. Two toner images are overlapped on the transfer drum.

After the drum transfer process is complete, the toner images are transferred onto the paper.

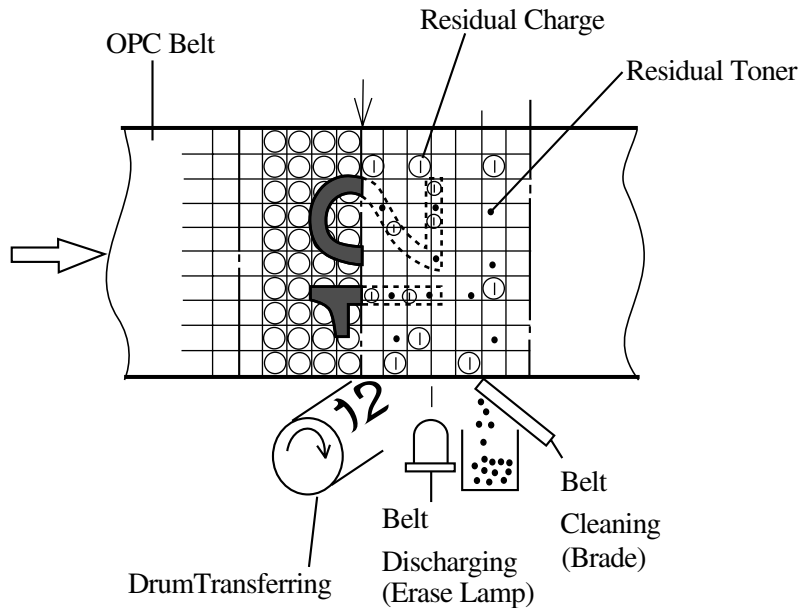

Fig. 4-18

4.2.3.5 Belt Discharging (Erase Lamp)

Belt discharging is defined as a process in which the erase lamp shines LED light onto the OPC belt, and discharges the residual charge for the electrical cleaning.

4.2.3.5.1 Structure of the Erase Lamp

The erase lamp to be used in the belt discharging process (see Fig. 4-8).

The light source of the erase lamp consists of 24 light emitting diodes (LED).

4.2.3.5.2 Process of Discharging

(see Fig. 4-19)

The toner image on the OPC belt is transferred onto the transfer drum; however, residual toner and residual electric charge still remain on the OPC belt.

The residual electric charge is discharged by shining LED light onto the OPC belt prior to proceeding to the next process.

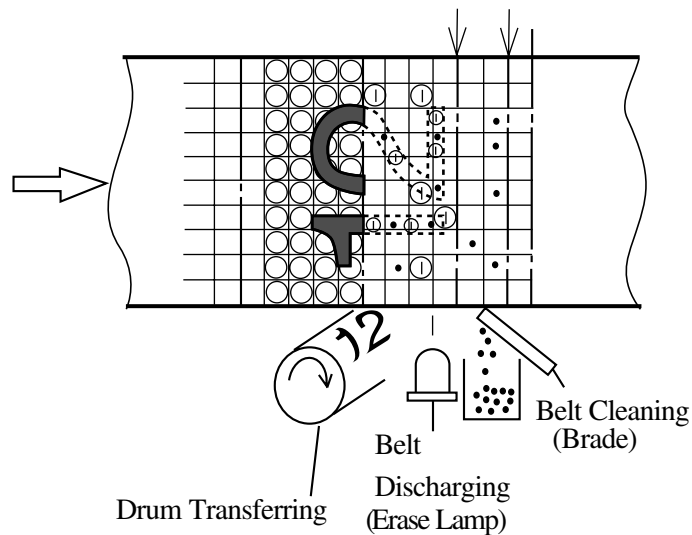

Fig. 4-19

4.2.3.6 Belt Cleaning

Belt cleaning is defined as process to remove the residual toner attached to the surface of the OPC belt.

4.2.3.6.1 Structure of Belt Cleaning

The blade for the belt cleaning is located on the belt cartridge (see Fig. 4-8).

4.2.3.6.2 Process of Belt Cleaning

(see Fig. 4-19)

Residual toner is defined as the remaining toner on the OPC belt that has not been transferred through the drum transfer process.

The belt cleaning blade is used to mechanically scavenge the residual toner from the surface of the OPC belt. Scavenged residual toner is collected and sent to the waste toner pack by the waste toner auger.

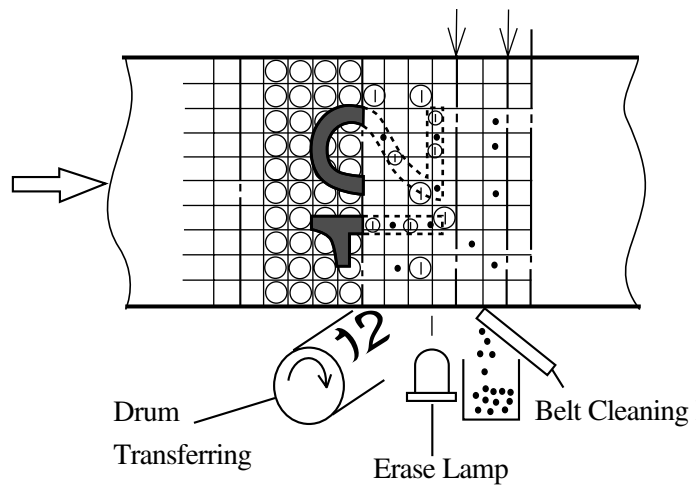

Fig. 4-20

4.2.3.7 Second Transfer (Paper)

Second transfer (paper) is defined as a process to transfer toner images from the transfer drum onto paper.

4.2.3.7.1 Structure of Second Transfer

The transfer roller for the second transfer is located as shown in Fig. 4-8.

The transfer roller is normally separated from the transfer drum. The transfer roller is positively biased by the power supply THV. The transfer roller contacts the transfer drum during the paper transfer process. Transported paper passes between the transfer roller and the transfer drum.

4.2.3.7.2 Process of Second Transfer

(see Fig. 4-21)

Paper is transported in synchronization with the transfer drum.

The transfer roller contacts the transfer drum. Transported paper passes between the transfer roller and transfer drum. In this instance, positive high voltage (THV) is applied to the transfer roller. Negatively charged toner is attracted to the positively charged paper.

After of the paper transfer, the transfer roller moves away from the transfer drum.

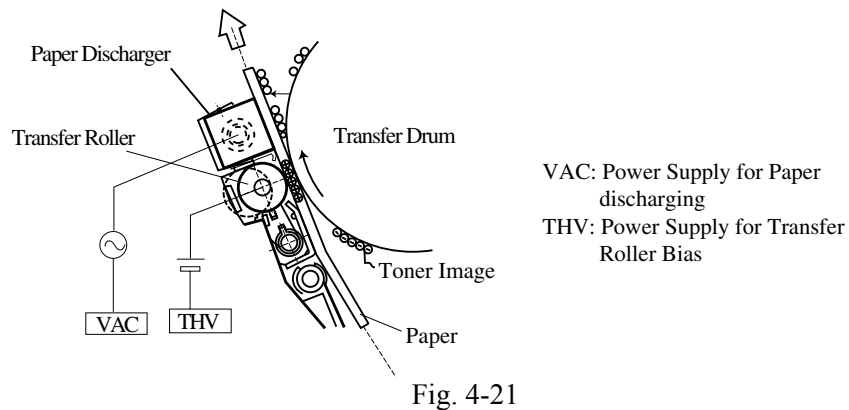

4.2.3.8 Paper Discharging

Paper discharging is defined as the process of applying an AC charge to the paper to separate it from the transfer drum.

4.2.3.8.1 Structure of Paper Discharge

(see Fig. 4-21)

The AC charger unit for discharge of paper is located as shown in Fig. 4-8.

The AC charger unit consists of the case and charger wire. The high AC voltage (VAC) is applied to the AC charger unit.

4.2.3.8.2 Process of Paper Discharge

(see Fig. 4-22)

In the transfer process, the paper tends to stick to the transfer drum due to the potential of the transfer drum.

An AC charge generated by the AC charger unit is applied to the transported paper which neutralizes or discharges the paper. The transported paper is separated from the transfer drum and transported to the fuser.

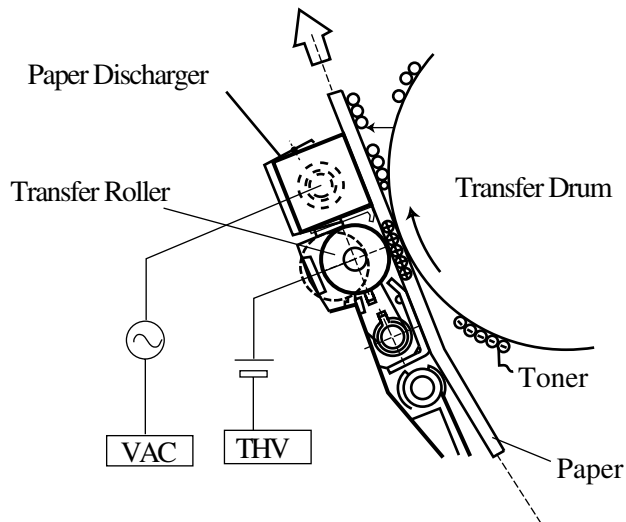

Fig. 4-22

4.2.3.9 Drum Cleaning

Drum cleaning is defined as a process to remove residual toner from the surface of the transfer drum.

4.2.3.9.1 Structure of Drum Cleaning

(see Fig. 4-23)

The drum cleaning unit is located as shown in Fig. 4-8.

A conductive cleaning brush rotates and cleans the surface of the transfer drum.

The drum cleaning roller is positively biased by the positive voltage FCBV. FCBV is injected into the cleaning brush as well, and the cleaning brush is self-biased by the resistance of the brush. The cleaning roller rotates in contact with the brush.

4.2.3.9.2 Process of Drum Cleaning

(see Fig. 4-23)

Residual toner remains on the surface of the transfer drum after the paper transfer process.

As the cleaning brush is biased to +FBBV, the brush attracts and removes the residual toner from the surface of the transfer drum while it is rotating.

As the cleaning roller is biased as $+FCBV > +FBBV$, the residual toner attracted into the brush is attracted to the cleaning roller.

The residual toner attracted to the surface of the cleaning roller is removed by the cleaning blade and moved to the waste toner bottle by the waste toner auger.

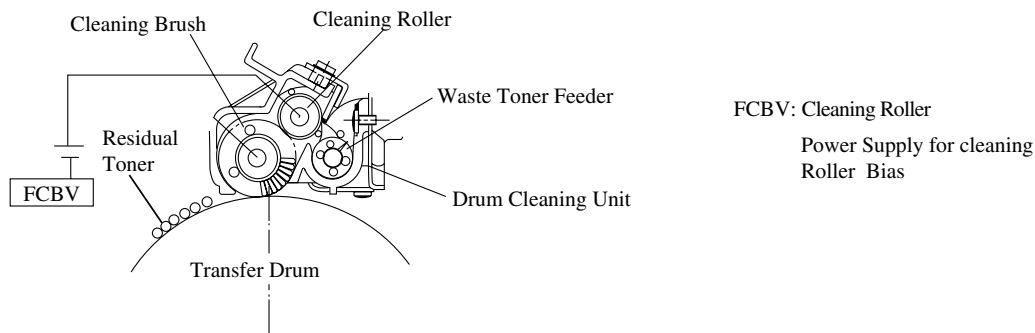

Fig. 4-23

4.3 Optical System

The printer uses a semiconductor laser diode as a light source. The laser diode is controlled on the basis of image data (video signal) through high-speed switching. The emitted laser beam is scanned over the OPC belt through a polygon mirror and lens. An electrostatic latent image is formed on the OPC belt.

4.3.1 Structure of the Optical System

(see Fig. 4-24)

The optical unit consists of following parts.

<u>Number</u>	<u>Name of Component</u>	<u>Function</u>
1	Laser Unit	Emits a laser beam.
2	Cylinder Lens	Condenses the laser beam.
3	Polygon Mirror	Scans the laser beam across the OPC.
4	F-Ø Lens	Focuses the laser beam.
5	Scanner Motor	Rotates the polygon mirror.
6	Mirror	Reflects the laser beam.
7	LDC (Laser Diode Control)	Controls circuitry for the laser diode
8	PD (Photodetector Sensor)	Used to detect laser beam start position.
9	BTD Mirror (Beam Timing Detect)	Guides the laser beam to the PD.

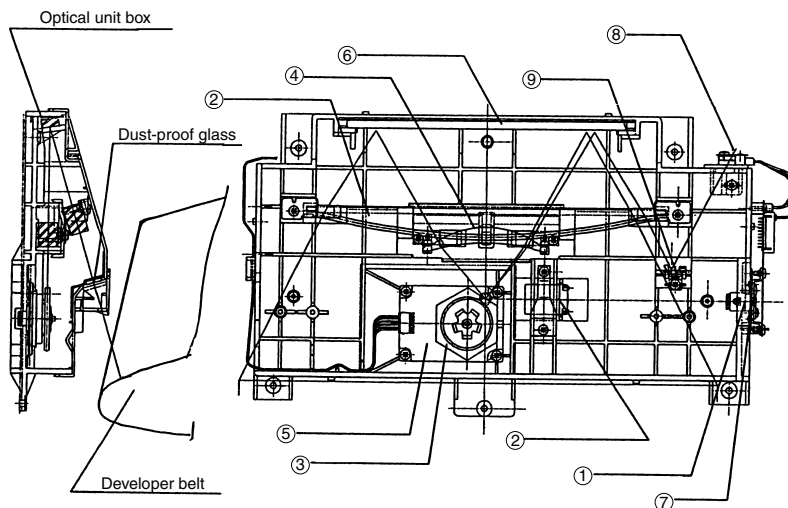

Fig. 4-24

4.3.2 Specifications of the Optical Unit

The specifications of the optical unit are described as follows:

<u>Component</u>	<u>Specification</u>
Rated Output of Laser Diode	5 mW
Wave Length of Laser Beam	Approximately 785 nm.
Scanning Density	600 dpi.
Scanning Width	310 mm.
Rotations Per Minutes of Scanner Motor	24,072 rpm.
Number of Polygon Mirror Faces	6

4.4 Paper Transportation System

4.4.1 Outline

The printer employs an automatic paper-feeding feature with the paper cassette. When toner images are formed on the transfer drum through the print system and the transfer system, a page is fed by the pick-up roller and transported to the registration roller. The registration roller carries the transported page to each unit in the proper order (the transfer unit, fuser, and paper exit unit) while synchronizing with the rotation of the transfer drum.

4.4.2 Structure of the Paper Transportation System

(see Fig. 4-25)

The paper transportation system consists of the following parts.

<u>Number</u>	<u>Name of Component</u>	<u>Function</u>
1	Paper Cassette	Holds paper
2	Pick-Up Roller	Separates and feeds paper one sheet at a time.
3	Registration Roller	Transports paper while synchronizing with the transfer drum.
4	Transfer	Carries out the print process by transferring toner images onto the pages. Consists of the transfer drum and roller.
5	Paper Discharger Unit	Separates the attached paper from the transfer drum by charging the AC corona.
6	Fuser Unit	Melts the toner images on the paper with the heat roller. The process fuses these toner images onto the paper.
7	Paper Exit Roller	Ejects the page from the printer after the paper fusing process is complete.

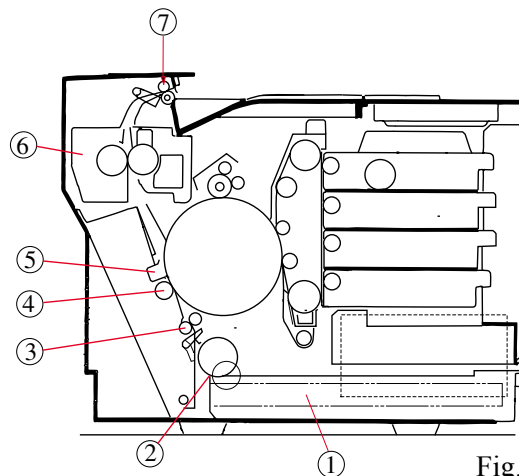

Fig. 4-25

4.5 Fuser

The Fuser employs a thermal fusing system - a heater in the roller. Paper carrying the toner images passes between the heat rollers. A combination of heat and pressure is applied to a page when it passes between the heat rollers so that the toner image is melted and fused on the paper (see Fig. 4-26).

4.5.1 Structure

The Fuser consists of the following components:

<u>Number</u>	<u>Name of Component</u>	<u>Function</u>
1	Fusing Roller	Heats toner with a quartz halogen lamp.
2	Back-Up Roller	Applies pressure and also contains a heater.
3	Fusing Heater	Heated by the halogen lamp.
4	Thermistor	Detects the temperature of the fuser roller's surface.
5	Thermal Fuse	Prevents the fuser roller from being overheated.
6	Oil Bottle	Houses the silicone oil for fusing.
7	Cleaning Roller	Cleans the fuser roller.

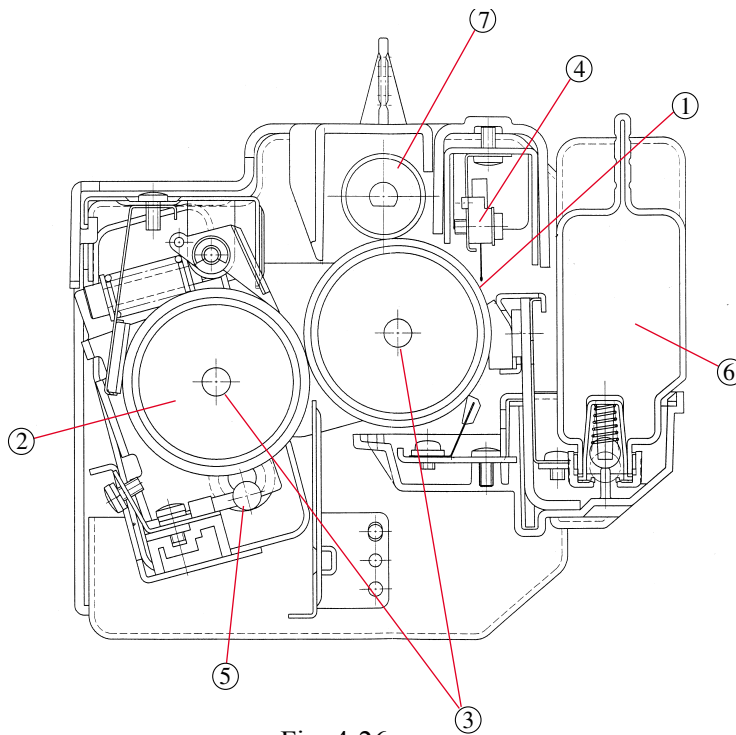

Fig. 4-26

4.5.2 Process of Fusing
(see Fig. 4-27)

Silicone oil, supplied from the oil bottle, is applied to the surface of the fuser roller and back-up roller. The toner image is transferred onto the paper, but is not yet fused to the paper.

The transported paper passes between the fuser roller and back-up roller. Each roller is heated up to approximately 150° C, and receives approximately 156N from the opposite heat roller. When the paper carrying the toner image passes between the two rollers, the toner image is melted and fused on the paper.

The paper carrying the fused image is separated from the heat rollers and ejected from the printer.

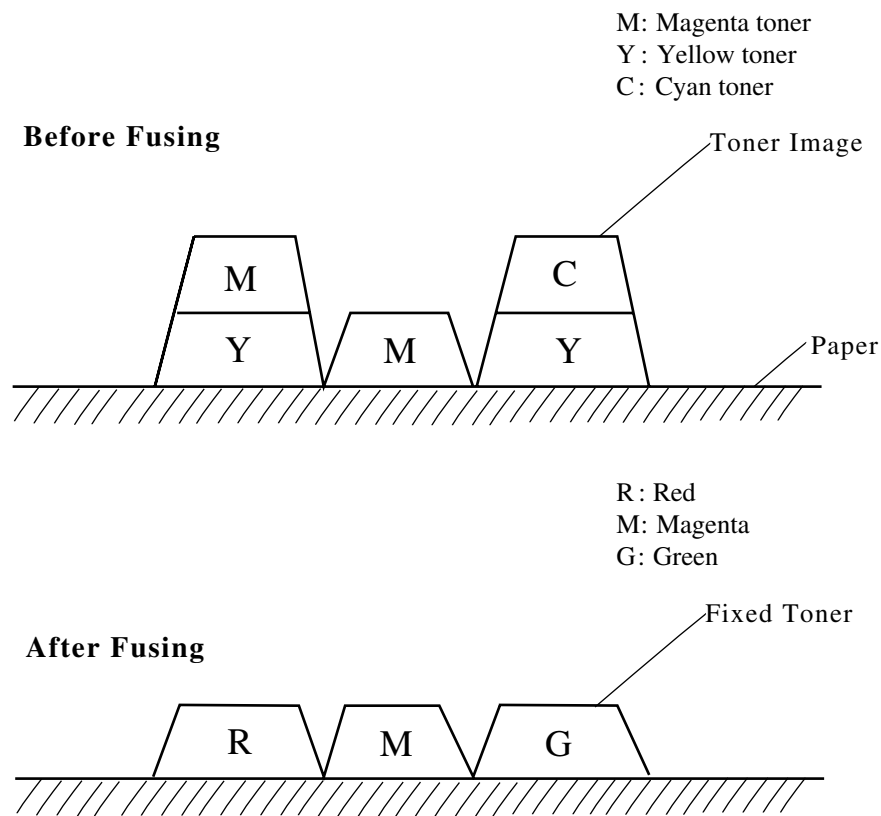

Fig. 4-27

4.6 Structure of the Control System

4.6.1 Electrical System and Function

Most of the main electrical components of this printer are controlled by the MCTL P.W.B.

4.6.1.1 Overview of the Structure of the Sequence Control

The basic structure of the sequence control is shown in Fig. 4-28.

<u>Number</u>	<u>Control Component</u>	<u>Function</u>
1	Print Process Control	Controls the print process through the paper feeding, printing, and transport.
2	Laser Output Control	Automatically controls the laser output.
3	Fuser Temperature Control	Controls the fusing heater so that the fuser roller and back-up roller maintain the set temperature.
4	Toner Sensing Control	Senses the absence or presence of toner.
5	Interface Control	Processes I/O signals to and from the external controller (host).
6	Operator/Control Panel	Displays the printer operation status on the panel.
7	Error Control	Stops the printer safely, and displays the status of the defects if any error occurs with the printer.

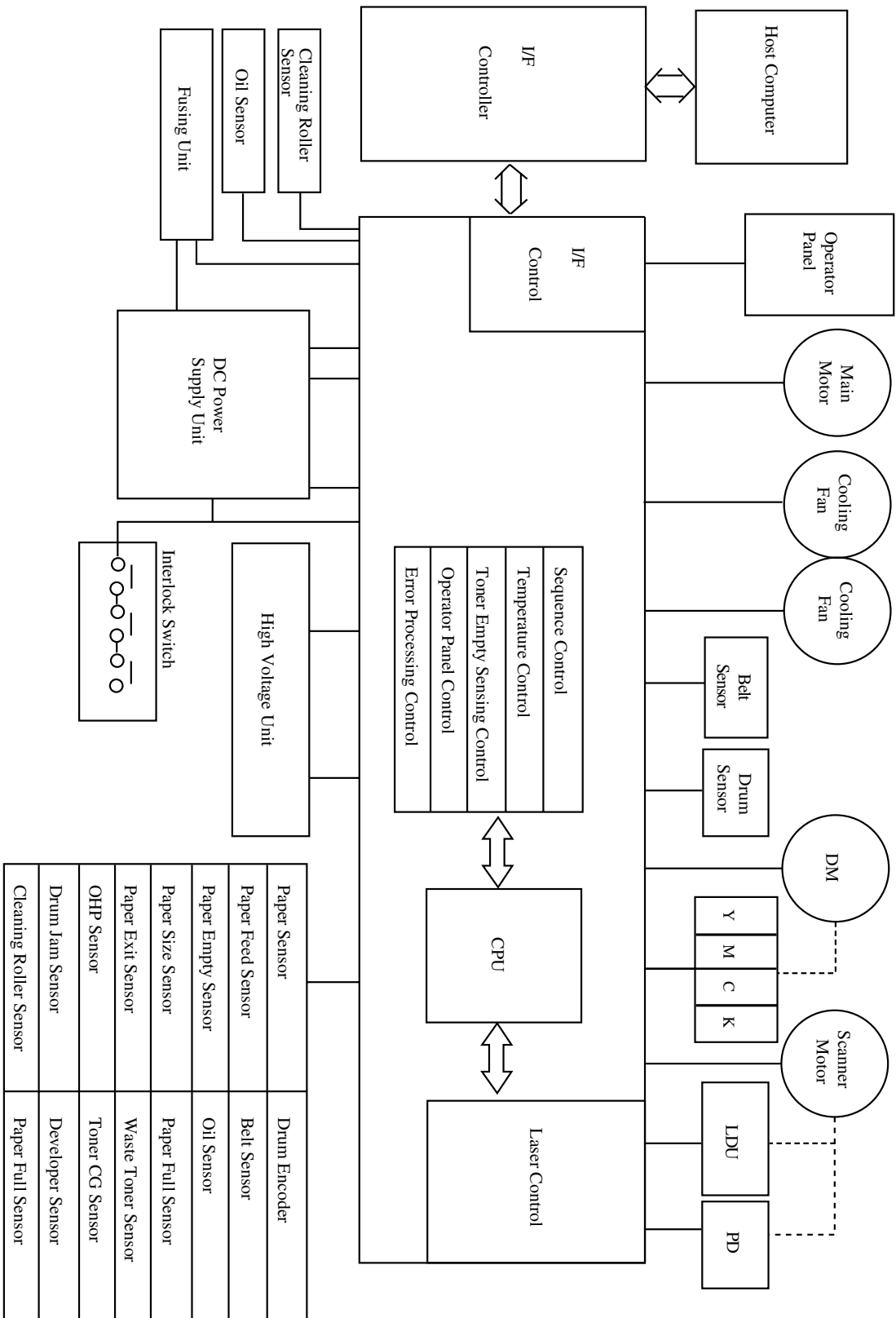

Fig. 4-28

4.6.1.2 Layout and Function of Electrical Components

4.6.1.2.1 Print P.W.B. (see Fig. 4-29)

<u>Number</u>	<u>Component</u>	<u>Function</u>
1	MCTL P.W.B.	Controls a series of processes of the Printer: Fuser Temperature Control, Laser Output Control, Operator Panel Indication, Toner Empty Sensing Control, Error Processing Control, Interface Control.
2	Panel P.W.B.	Displays the Printer's operation status.
3	LDU P.W.B.	Controls the drive and output of the laser diode.
4	PDU P.W.B.	Detects the laser diode emission and the position of its beam (included in the optical unit).
5	Erase Lamp	Discharges the OPC belt by shining the LED beam onto the OPC belt (included in the optical unit).
6	IOD1 P.W.B.	Relays the signals between the controlled parts and MCTL P.W.B., and drives the controlled parts.
7	IOD2 P.W.B.	Relays the signals between the controlled parts and MCTL P.W.B., and drives the controlled parts.
8	Low Voltage Power Supply (LVPS)	Provides the printer with the power for the printer control.
9	High Voltage Power Supply (HVPS)	Provides the printer with the high-voltage power necessary for the printing process.

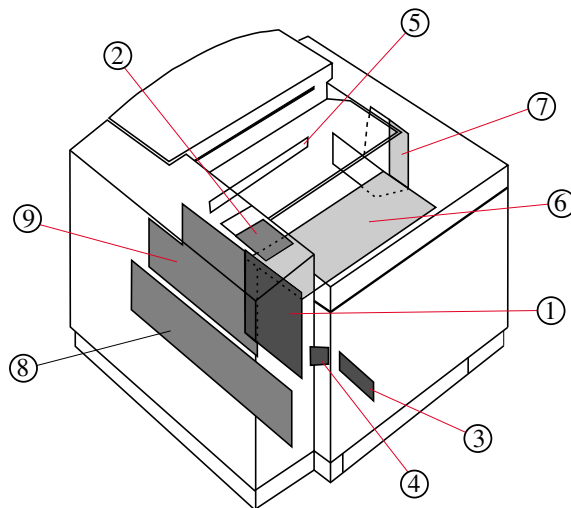

Fig. 4-29

4.6.1.2.2 Motors and Switches
(see Fig. 4-30)

<u>Number</u>	<u>Component</u>	<u>Code</u>	<u>Function</u>
1	Main Motor	MM	Drives the OPC belt and the paper transport system.
2	Developer Motor	DM	Drives the toner cartridge and the developing system.
3	Scanner Motor	SCM	Scans the laser beam.
4	Ozone Fan	OZFAN	Vents the ozone from the printer (charger unit).
5	Heater Fan	HTFAN	Exhausts the heat of the fuser.
6	Controller Fan	CTLFAN	Exhausts the heat of power supply unit and controller.
7	Front Door Interlock Switch	DSW1	Used as a safety interlock switch that stops the motors when the front door is opened.
8	Paper Exit Cover (Top Door) Interlock Switch	DSW2	Used as a safety interlock switch that stops the motors when the top door is opened.
9	Back Cover (Transfer Unit Door) Interlock Switch	DSW3	Used as a safety interlock switch that stops the motors when the transfer unit door is opened.

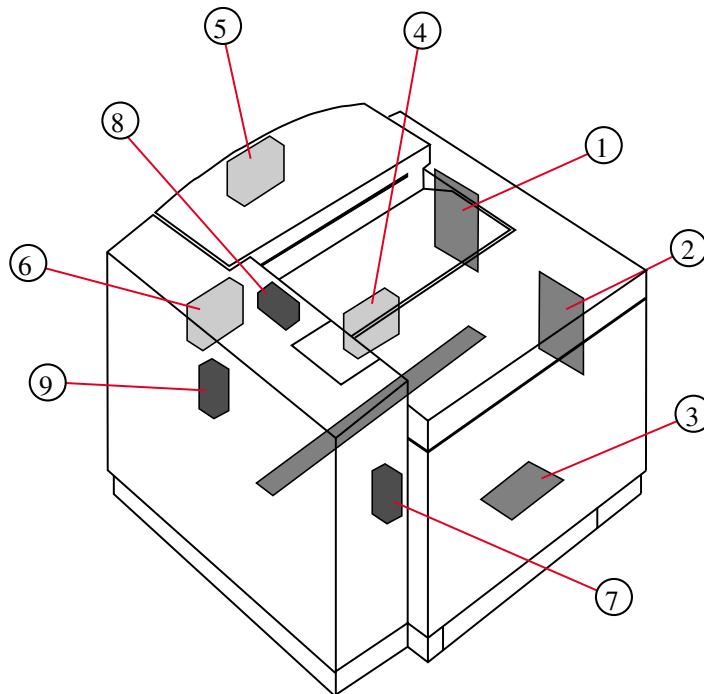

Fig. 4-30

4.6.1.2.3 Clutches
(see Fig. 4-31)

<u>Number</u>	<u>Component</u>	<u>Code</u>	<u>Function</u>
1	Paper Feeding Clutch	PCLU	Feeds paper by coupling the feeding roller to the main gear unit at the timing of the paper feeding.
2	Registration Clutch	RECL	Transports paper by coupling the registration roller to the main gear unit as synchronized with the rotation of the transfer drum.
3	Fuser Clutch	FUCL	Drives the fusing roller by coupling the fuser unit to the main gear unit.
4	Cleaner Clutch	FBCL	Drives the brush of the drum cleaner by coupling the cleaner clutch to the main gear unit at the timing of the drum cleaning.
5~8	Developer Clutch	DCL (Y,M,C,K)	Drives the magnet roller of the desired color toner cartridge by coupling the toner cartridge to the developer gear unit at the time of developing.
9	Developer Cam Clutch Unit	PSL(MC) PSL(KY)	Moves the desired color toner cartridge to the developing position at the time of the developing. (Located in the door assembly).
10	Transfer Cam Clutch	TRCM	Brings the transfer roller into contact with the transfer drum surface.
11	Cleaner Cam Clutch	FBCM	Brings the cleaning brush into contact with the transfer drum surface.

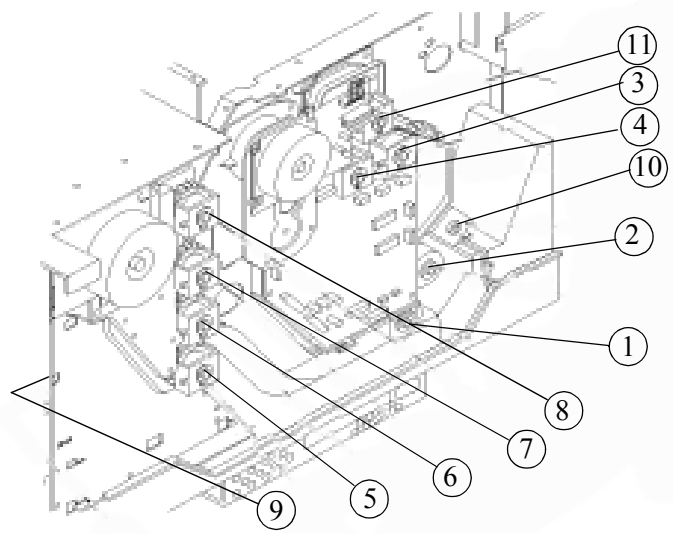

Fig. 4-31

4.6.1.2.4 Sensors
(see Fig. 4-32)

Number	Component	Code	Function
1	Paper Size Sensor	PSU	Detects the paper size.
2	Paper Feed Sensor	PT1	Detects the paper being fed.
3	Paper Exit Sensor	PT2	Detects the paper being ejected.
4	Paper Sensor	PEU	Detects the paper in the cassette.
5	Oil Sensor	OIL	Detects if the fuser unit has oil.
6	OHP Sensor	OHP	Detects if material in the paper cassette is OHP.
7	Drum Paper Jam Sensor	DPJ	Detects if the paper is wound around the transfer drum.
8	Drum Encoder	EN	Detects irregular rotation of the transfer drum.
9	Photo Belt Sensor	PBS	Detects revolution of the belt.
10	Toner Empty Sensor	TPD/TTR	Detects the presence of toner for each toner cartridge.
11	Waste Toner Sensor	WTS (LED/TR)	Detects if the waste toner bottle is full of waste toner.
12	Home Position Sensor	GHP1/ GHP2	Detects toner cartridge position.
13	Cleaning Roller Sensor	CRS	Detects if the cleaning roller is available in the fuser unit.
14	Fuser Unit Temperature Sensor	TH	Detects the fuser temperature.
15	Exit Paper Full Sensor	PFUL	Detects tray full condition for exit tray.
16	Toner Key Sensor	TNK	Detects the presence of the key on a toner cartridge.

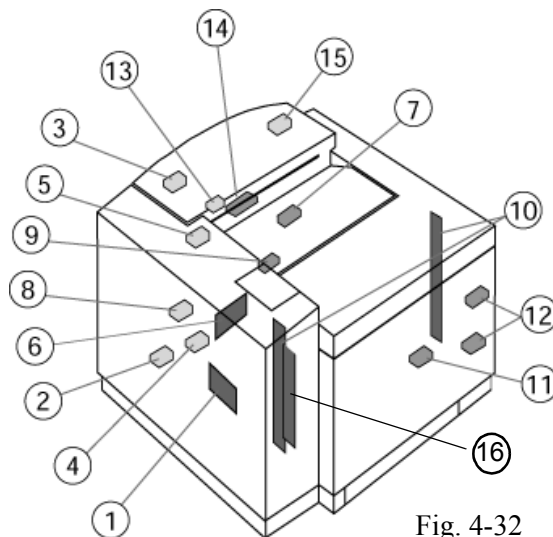

Fig. 4-32

4.6.2 Control System

4.6.2.1 Control of the Print Process

The Micro CPU mounted on the MCTL P.W.B. controls the print processes (see Fig. 4-33).

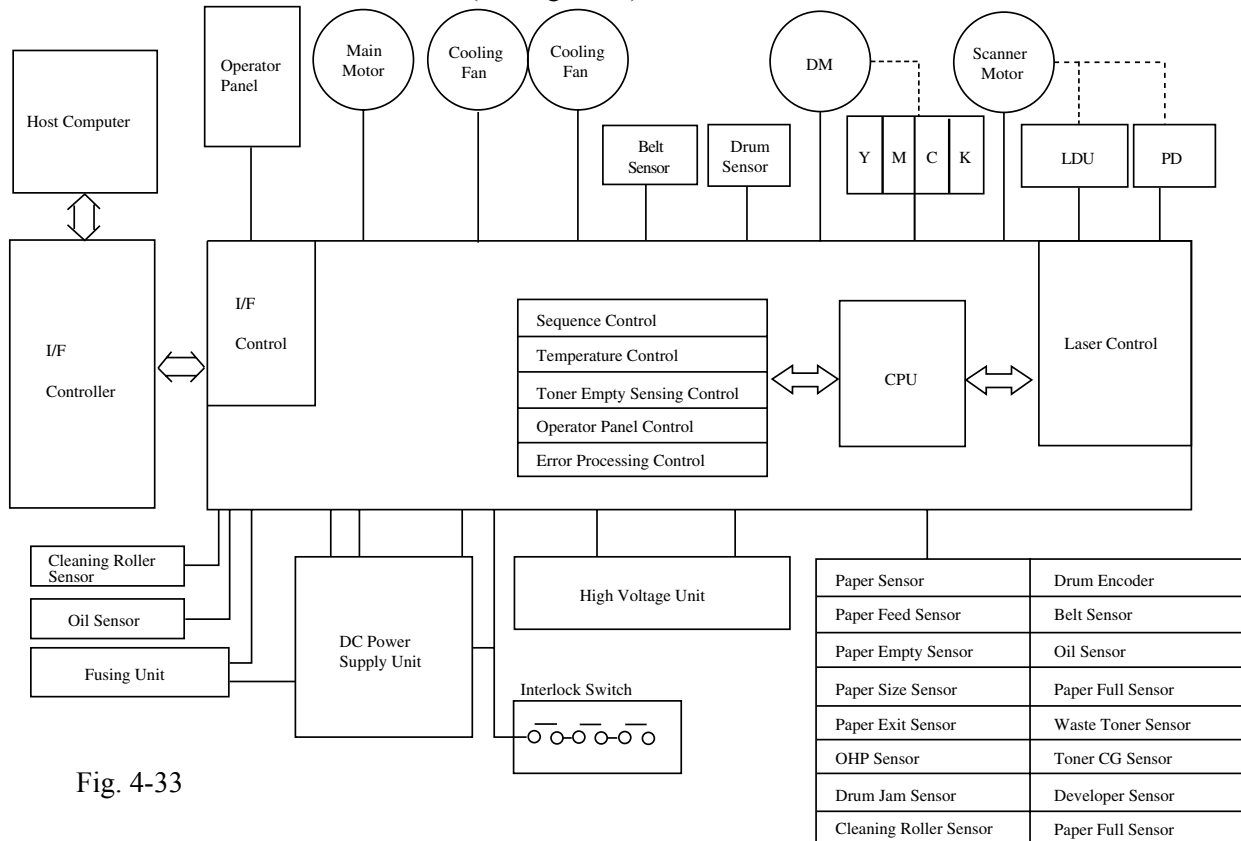

Fig. 4-33

4.6.2.1.1 Control Block Diagram (see Fig. 4-33)

Number	Name of Control	Function
1	Sequence Control	Controls the print sequence of the printer.
2	Temperature Control	Controls the temperature of the fuser unit.
3	Toner Empty Sensing Control	Reports the toner empty status of each toner cartridge.
4	Operator Control Panel	Controls the operator panel LEDs and the operation signals.
5	Error Processing Control	Senses the errors occurring in the printer and stops the printer as necessary.
6	Interface Control	Controls the receipt and transmission of signals from the external controller.
7	Laser Control	Controls the laser scanning and laser power.

4.6.2.2 Laser Drive Control Circuit

The laser drive control circuit (LDC) consists of the video signal input circuit, drive circuit, laser diode, output detection circuit, and output control circuit (see Fig. 4-34).

4.6.2.2.1 Operation of Laser Drive Control Circuit

When a video signal is input, the laser drive circuit switches the laser diode based on the video signal, and emits a laser beam.

The output value of the emitted laser beam is detected by the photo detector (PD), and feeds back to the output control circuit.

The output control circuit compares and controls the set value for the laser output as well as the value fed back from the output detection circuit, so that the emitted output of the laser diode remains constant.

The laser beam scanned by the scanner motor is detected by the beam detector (PD), and is output as the synchronized position signal (BDT). This signal is to initiate the printing.

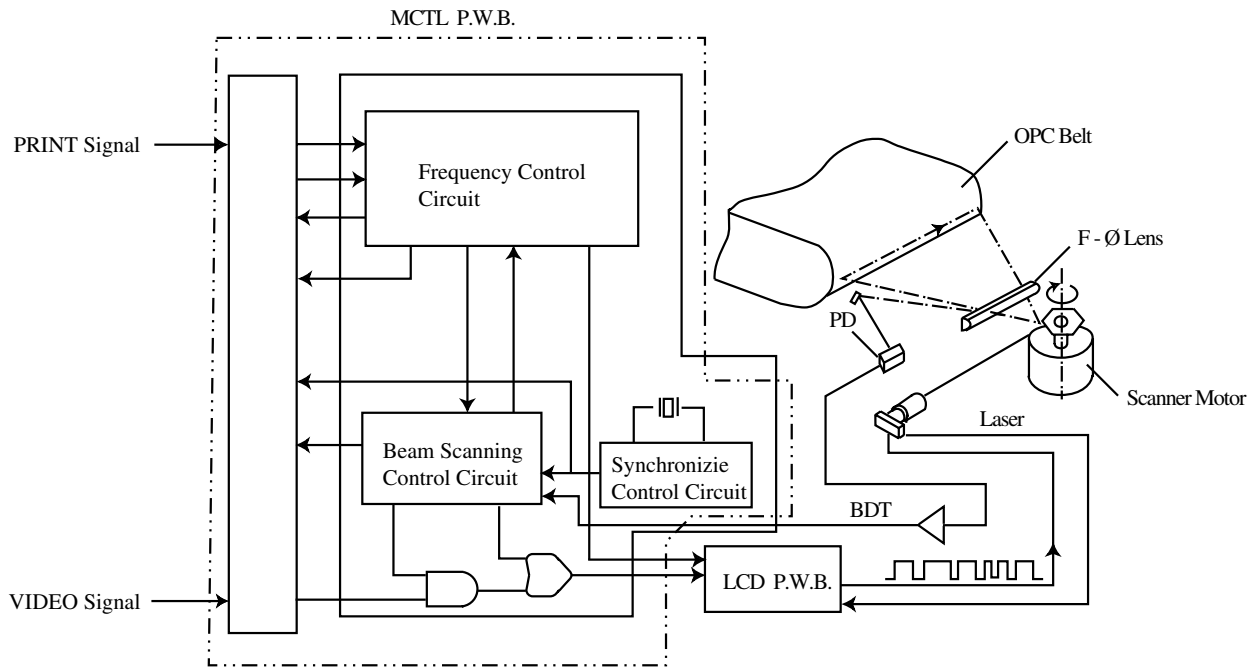

Fig. 4-34

4.6.2.3 Control of Fusing Temperature

Each roller in the fuser is controlled to maintain an appropriate temperature so that the toner will be melted on the paper.

4.6.2.3.1 Basic Structure of Temperature Control (see Fig. 4-35)

<u>Component</u>	<u>Function</u>
FLS	Switches On or Off power to the Fuser Lamp.
TFU1/TFU2 (Thermal fuse)	Shuts down the power when devices reach abnormally high temperatures.
TH (Thermistor)	Detects surface temperature of Fuser Roller.
RY (Relay)	Shuts down power to circuits RY-1 and RY-2 when the fuser reaches an abnormally high temperature.
GA/CPU	Processes the temperature signal (microcomputer).
CM1	Used as a sensor circuit for temperature signal (for ACOFF signal).
CM2	Used as a sensor circuit for temperature signal (for HON signal).
CM3	Used as a sensor circuit for temperature signal (for processing).
Q	Used as a sensor circuit for shut-down by the thermistor (for THERR signal).
HR	Heats the roller.
BR	Heats the back-up roller.

4.6.2.3.2 Characteristics of Signal (see Fig. 4-35)

Signal	Function
HON-N	Turns on/off the heater in side the fusing roller.
ACOFF	Turns off the relay RY1 when it is sensed too hot.
THERR	Detects the shut-down by the thermistor.
AD	Converts the temperature sensing signal to AD.

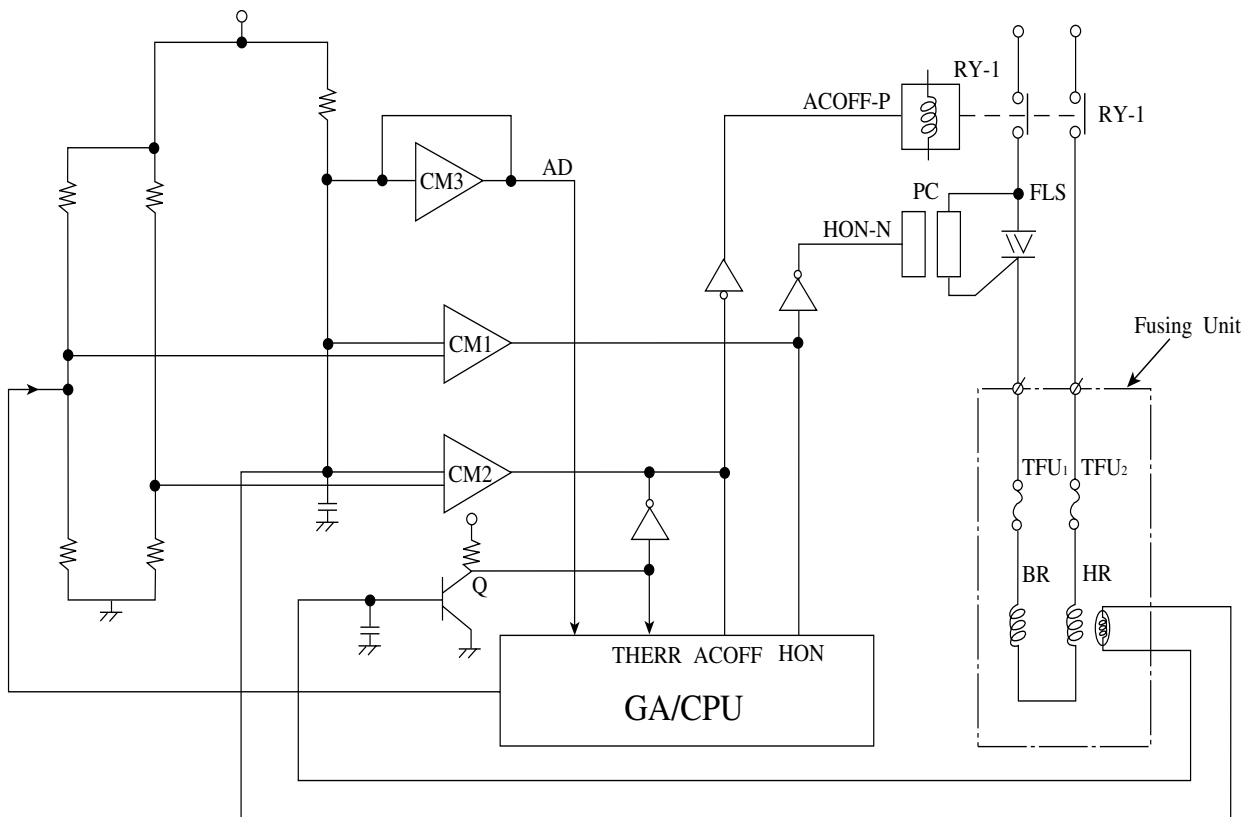

Fig. 4-35

4.6.2.3.3 Controlled Temperature and Safety

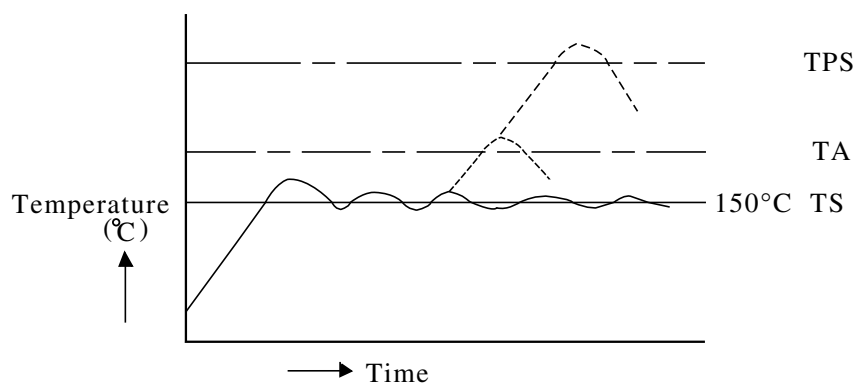

Fig. 4-36

<u>Signal</u>	<u>Function</u>
TS	Maintains the set temperature of approximately 150°C for fusing by turning on/off the thyristor.
TA	Used as a reference temperature (approximately 185°C) to identify that it is excessively hot inside the fuser. When it reaches 185°C, the relay RY turns off, the power to the heat lamp is shut down, and the printer stops.
TPS	Limits temperature through the use of a temperature fuse which shuts down the power to the heat lamp if the temperature control circuit breaks down. When the temperature fuse is blown, the printer will stop.

4.6.2.3.4 Safety Control by Temperature Control Signal

<u>Error</u>	<u>Explanation</u>
H0	When THERR signal is input, the operator panel displays “H0”, and the printer stops.
H2	If the temperature of the fuser will not reach to the required point “T1” after a given time has elapsed, the operator panel displays “H2”, and the printer stops.
H3	If the “Heater On” signal continues after a given period of time, the operator panel displays “H3”, and the printer stops.
H4	If the temperature within the fuser becomes unusually hot, and when ACOFF signal is input, the operator panel displays “H4”, and the printer stops.

4.6.2.4 Interface Control

4.6.2.4.1 Interface Type

This video interface handles serial image data of graphic elements which correspond to printed pixels, but does not employ the accumulation of the image data by the buffer.

The video signal of the data directly switches the semiconductor laser diode on and off to form the image.

4.6.2.4.2 Interface Connection

The interface connector of the printer is connected to the host system (see Fig. 4-37).

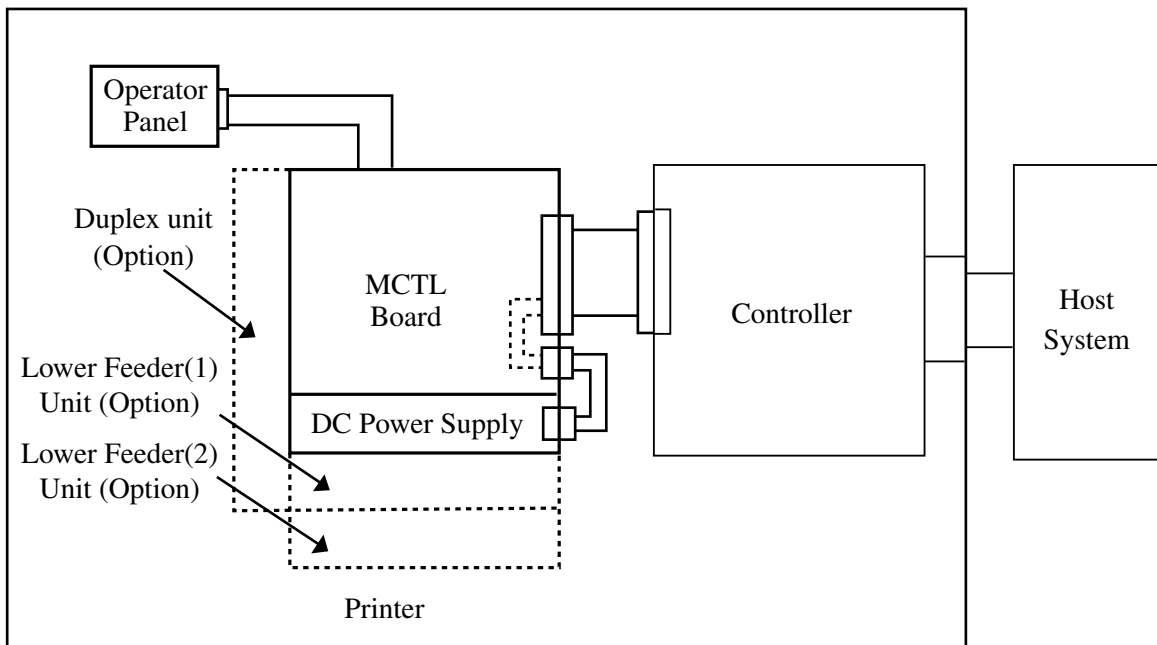
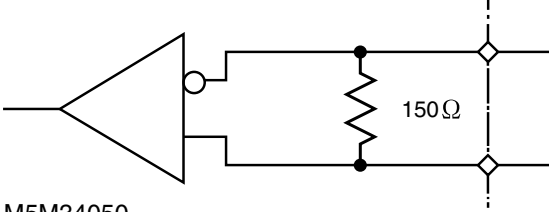
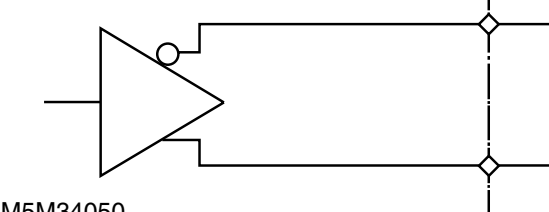
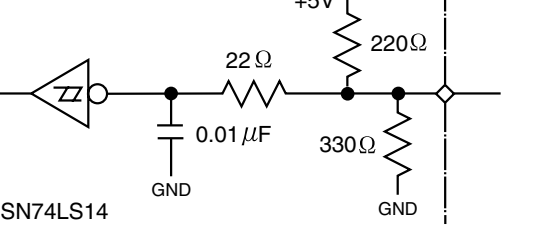
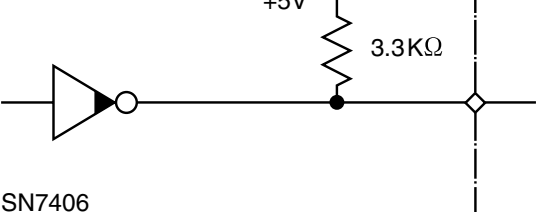

Fig. 4-37

4.6.2.4.3 Interface Circuit (Printer side)

The table below shows the interface circuit for each signal.

Table 4.1: Interface Circuit

Number	Interface Circuit	Signal Name
1	 <p>M5M34050</p>	<ul style="list-style-type: none"> •VIDEO-N •VIDEO-P
2	 <p>M5M34050</p>	<ul style="list-style-type: none"> •HSYNC-N •HSYNC-P
3	 <p>SN74LS14</p>	<ul style="list-style-type: none"> •PRREQ-N •COMMAND-N •ID1-N •ID2-N
4	 <p>SN7406</p>	<ul style="list-style-type: none"> •VSYNC-N •IREADY-N •STATUS-N •KEY-STATUS-N

4.6.2.4.4 Connector Pin Assignment

Table 4-2: Connector Pin Assignment

Pin No.	Signal Name	Pin No.	Signal Name
1A	PSGND	1B	+5V
2A	PSGND	2B	+5V
3A	PSGND	3B	+5V
4A	PSGND	4B	+5V
5A	PSGND	5B	+5V
6A	PSGND	6B	+5V
7A	PSGND	7B	+5V
8A	PSGND	8B	+5V
9A	VIDEO-P	9B	VIDEO-N
10A	RET (GND)	10B	Reserved
11A	HSYNC-P	11B	HSYNC-N
12A	ID2-N	12B	Reserved
13A	RET (GND)	13B	VSYNC-N
14A	RET (GND)	14B	Reserved
15A	RET (GND)	15B	STATUS
16A	RET (GND)	16B	IREADY-N
17A	RET (GND)	17B	Reserved
18A	RET (GND)	18B	COMMAND
19A	RET (GND)	19B	PRREQ-N
20A	RET (GND)	20B	Reserve
21A	ID1-N	21B	Reserve
22A	RET (GND)	22B	KEY_STATUS-N
23A	Reserved	23B	Reserved
24A	Reserved	24B	Reserved
25A	RET (GND)	25B	Reserved
26A	RET (GND)	26B	Reserved
27A	RET (GND)	27B	Reserved
28A	RET (GND)	28B	Reserved
29A	RET (GND)	29B	Reserved
30A	RET (GND)	30B	Reserved
31A	RET (GND)	31B	Reserved
32A	RET (GND)	32B	Reserved

4.6.3 Low Voltage Power Supply

4.6.3.1 Output and Use

<u>Output Terminal</u>	<u>Rated Output</u>	<u>Function</u>
+5V-1	4.8~5.3V, 8.5A	For control of the printer.
+5V-1R	4.8~5.3V, 8.5A	For control of the laser.
+5V-2	4.8~5.3V, 8.5A	For control of the interface. (7A MAX)
+24V-1	+24V, 6.5A	For control of printer charging.
HP	120V, 8A	For connection of the Fuser Heater (HP).
HN	220V, 5A	For connection of the Fuser Heater (HN).

4.6.3.2 Layout of Connector Pin Assignment (see Fig. 4-38)

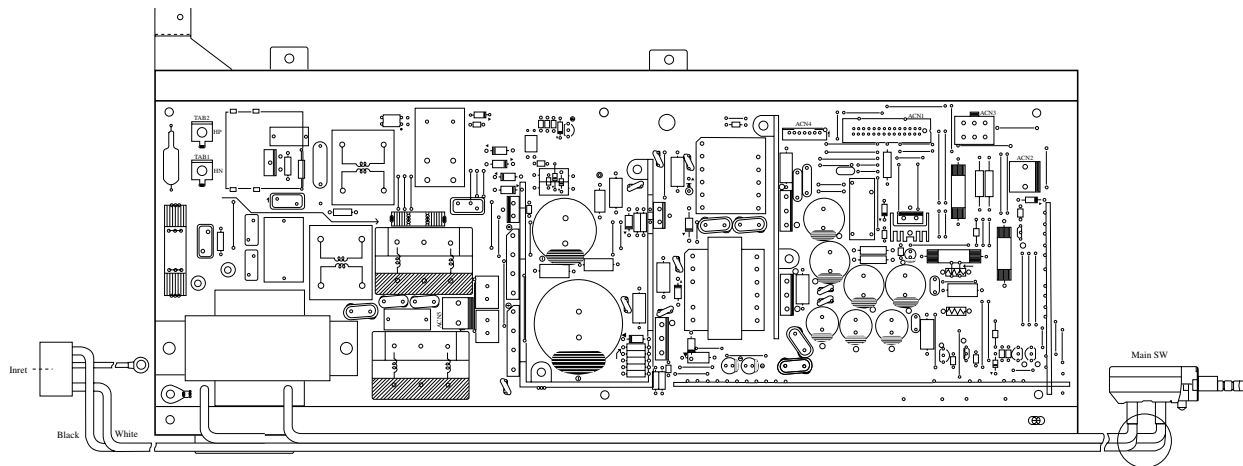

Fig. 4-38

4.6.3.3 Connector Pin Assignment

4.6.3.3.1 ACN1 (Molex : 53313-2815)

Pin No.	Signal Name	Interface
1	+5V-1	+5V-1 Output
2	DCOFF2-P	+5V-2D OFF Signal
3	+5V-1	+5V-1 Output
4	SGND	Signal Ground (+5V type ground)
5	+5V-D	+5V-D Output
6	SGND	Signal Ground (+5V type ground)
7	+5V-D	+5V-D Output
8	SGND	Signal Ground (+5V type ground)
9	ACSYNC-N	AC Zero-Cross Signal (Open Collector Output)
10	SGND	Signal Ground (+5V type ground)
11	+24V	+24V Output corresponding to Door Switch.
12	DCOFF1-P	OFF Signal (Pull-Up required)
13	+5V-1R	+5V through the relay when +24V-1 is shut down.
14	ACOFF-P	AC Forced Shut-Down Signal (Pull-Up required)
15	HON-N	Heater On Signal (Pull-Up required).
16	TESTI2	Terminal for Dielectric Strength Test.
17	+24V-1	+24V Output through Door Switch.
18	TESTO2	Terminal for Dielectric Strength Test.
19	+24V-1	+24V Output through Door Switch.
20	TESTI1	Terminal for Dielectric Strength Test.
21	+24V-1	+24V Output through Door Switch
22	TESTO1	Terminal for Dielectric Strength Test.
23	+24V-1	+24V Output through Door Switch
24	PGND	Power Ground (+24V type ground)
25	PGND	Power Ground (+24V type ground)
26	PGND	Power Ground (+24V type ground)
27	PGND	Power Ground (+24V type ground)
28	PGND	Power Ground (+24V type ground)

4.6.3.3.2 ACN2 (Molex : 5277-02A)

Pin No.	Signal Name	Interface
1	DSW-O	+24V Output through Door Switch.
2	DSW-I	+24V Output through Door Switch.

4.6.3.3.3 ACN1 (Molex : 53324-0710)

Pin No.	Signal Name	Interface
1	+5V-1	+5V-1 Output
2	+5V-D	+5V-1 Output
3	SGND	Signal Ground (+5V type ground)
4	+24V-2	+24V-2 Output
5	+24V-2	+24V-2 Output
6	PGND	Power Ground (+24V type ground)
7	PGND	Power Ground (+24V type ground)

4.6.3.3.4 ACN3 (Molex : 5566-06A)

Pin No.	Signal Name	Interface
1	+5V-2	+5V-2 Output
2	+5V-2D	+5V-2D Output
3	+5V-2D	+5V-2D Output
4	SGND	Signal Ground (+5V type ground)
5	SGND	Signal Ground (+5V type ground)
6	SGND	Signal Ground (+5V type ground)

4.6.4 High Voltage Power Supply

4.6.4.1 Output and Function

Function	Name of Power Supply	Max Output Voltage of Power Supply
Charging	CHV(-)	4.6kV 600 μ A
First Transfer	CBV(-)	200~900
Developing Bias (Y, M)	DBV(-A)	200~400
Developing Bias (C, K)	DBV(-B)	200~400
Second Transfer	THV(+)	400~3,000
Transfer Roller Cleaning	THV(-)	600
Paper Discharging	ACV(~)	4.9k
Paper Discharging	DCV(+)	400
Drum Cleaning	FCBV	200~1,000

4.6.4.2 Layout of Connector Pin Assignment

4.6.4.2.1 BCN1 (Molex 53313-1815)

(see Fig. 4-39)

Pin No.	Signal Name	Interface
1	24V	24V
2	PGND	PGND
3	FUCHK	Sensor Signal of Fuser Unit Installation
4	PGND	PGND
5	ACVON-N	AC Output ON Signal
6	PWMON-N	PWM Control ON Signal
7	CHVON-ON	CHV Output ON Signal
8	CHVERR	CHV ERROR Sensor Signal
9	CBVPWM-N	CBV PWM Control Signal
10	THVRON-N	THV ON Signal
11	DBVYMPWM-N	DBV PWM Control Signal
12	THVPWM-N	THV PWM Control ON Signal
13	DBVCKPWM-N	CBV PWM Control Signal
14	THV	Transfer Voltage Select Signal
15	FCBVPWM-N	FCBV PWM Control Signal
16	TH1	Thermistor Temperature Sensor Signal
17	NC	NC
18	TH2	Thermistor Temperature Sensor Signal

4.6.4.2.2 BCN2 (Molex Type: 53324-0410)
(see Fig. 4-39)

Pin No.	Signal Name	Interface
1	TH1	Thermistor1
2	TH2	Thermistor2
3	FUCHK	Fuser Check
4	FUCHKGND	GND

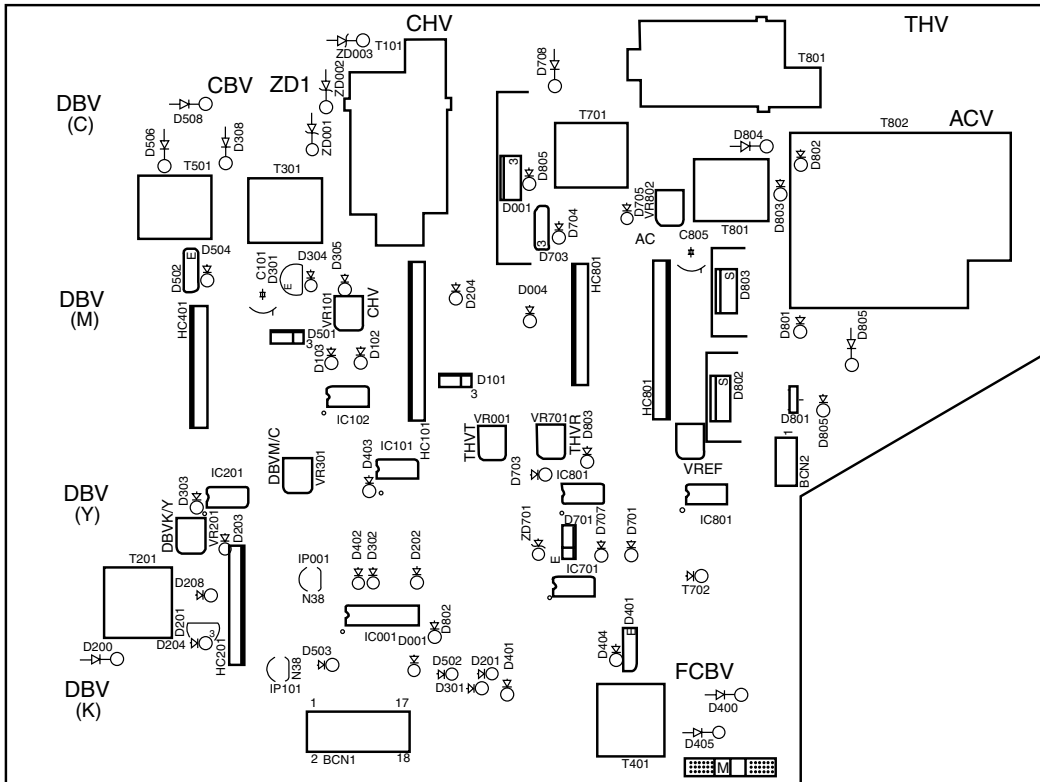
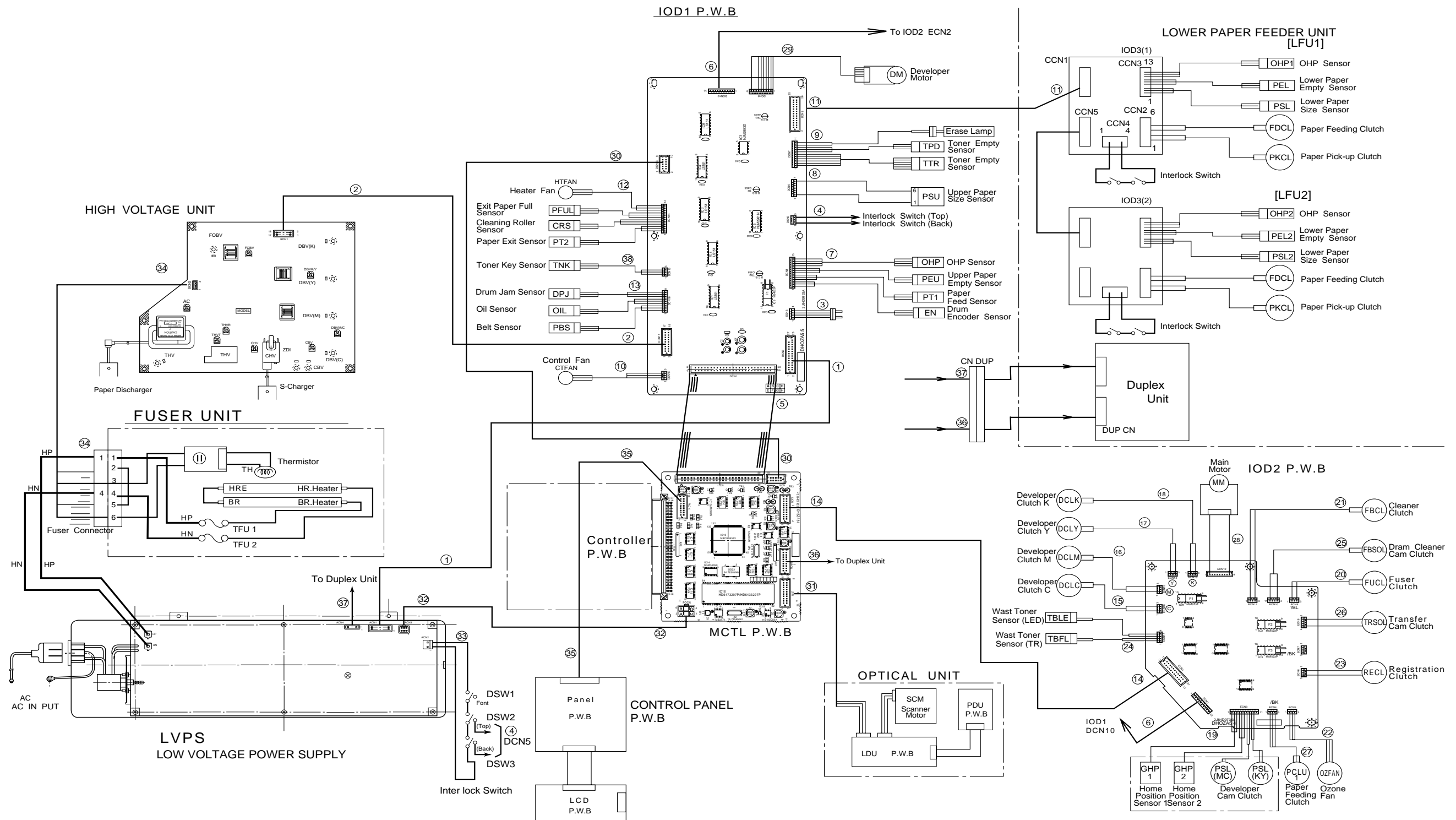

Fig. 4-39

4.6.4 Printer Wiring Diagram



Note:
Circled reference numbers refer to wire tables found in Section 4.6.5.2.

Fig. 4-40

4.6.4.1 Symbol and Part Names

Symbol	Component	Symbol	Component
LVPS	Low Voltage Power Supply	IOD1	IOD1 P.W.B.
DSW1	Interlock Switch (Front)	OHP	OHP Sensor
DSW2	Interlock Switch (Top)	PEU	Upper Paper Empty Sensor
DSW3	Interlock Switch (Back)	PT1	Paper Feed Sensor
FUSER	Fuser	EN	Drum Encoder Sensor
TH	Thermistor	ERASE LAMP	Erase Lamp
HR	Heater Roller	TDP TTR	Toner Empty Sensor
BR	Back-Up Roller	TNK	Toner Key Sensor
TFU1 TFU2	Thermal Fuse	PSU	Upper Paper Size Sensor
HVPS	High Voltage Power Supply	PFUL	Exit Paper Full Sensor
MCTL	MCTL P.W.B.	CSR	Cleaning Roller Sensor
PANEL	Operator Panel P.W.B.	PT2	Paper Exit Sensor
LCD	LCD P.W.B.	DPJ	Drum Jam Sensor
OPTICAL UNIT	Optical Unit	OIL	Oil Sensor
SCM	Scanner Motor	BPS	Belt Sensor
PDU	PDL P.W.B.	TBLE TBFL	Waste Toner Sensor
LDU	LDU P.W.B.	IOD2	IOD2 P.W.B.
MM	Main Motor	PSL (MC) PSL (KY)	Developer Retract Clutch
DM	Developer Motor	FBCM	Cleaning Cam Clutch
FUFAN	Fuser Fan Motor	TRCM	Transfer Cam Clutch
CTFAN	Control Fan Motor	LFU	Lower Paper Feed Unit
OZFAN	Ozone Fan Motor	IOD3	IOD3 P.W.B.
DVLK DVLY DVLM DVLC	Developer Clutches (K, Y, M, C)	PCLU	Upper Paper Feeding Clutch
PCLU	Upper Paper Feeding Clutch	RECL	Registration Clutch
FUCL	Fuser Clutch	FBCL	Cleaning Clutch

4.6.4.2 Connector Pin Assignments
(see Fig. 4-40)

4.6.4.2.1 IOD1 P.W.B. DCN2 - Power Supply Unit ACN1 (28 pins)
IOD1 DCN2-ACN1 (26 28) (see Fig. 4-40).

①

Pin Number	Signal	Pin Number	Signal
1	+5v-1	2	DCOFF2-P
3	+5v-1	4	SGND
5	+5v-D	6	SGND
7	+5v-D	8	SGND
9	ACSYNC-N	10	SGND
11	+24	12	DCOFF1-P
13	+5v-1R	14	ACOFF-P
15	HON-N	16	TESTI2
17	+24v-	18	TESTO2
19	+24v-	20	TESTI1
21	+24v-	22	TESTO1
23	+24v-	24	PGND
25	PGND	26	PGND
27	PGND	28	PGND

4.6.4.2.2 IOD1 P.W.B DCN17 High Voltage Power Supply BCN1 (18 pins)
IOD1 DCN17 (18) (see Fig. 4-40).

②

Pin Number	Signal	Pin Number	Signal
1	+24v-1	2	PGND
3	FUTEMP	4	PGND
5	ACVON-N	6	PWMON-N
7	CHVON-N	8	CHVERR
9	CBVPWM-N	10	THVRON-N
11	DBV(MC)PWM-N	12	THVPWM-N
13	DBV(KY)PWM-N	14	THV-I
15	FCBVPWM-N	16	TH1
17	AC_DCON-N	18	TH2

4.6.4.2.3 For Factory Use Only DCN3 (4P)
DCN3 (see Fig. 4-40).

③

Pin Number	Signal
1	TESTO1
2	TESTI1
3	TESTO2
4	TESTI2

4.6.4.2.4 IOD1 P.W.B. (DCN5)
IOD1 DCN5 (see Fig. 4-40).

④

Pin Number	Signal
1	REARDOPEN-P
2	N.C
3	TOPDOPEN-P

4.6.4.2.5 MCTL P.W.B. 11CN1 IOD1 P.W.B DCN1 (50 pins)
MCTL IOD1 (50 26) (see Fig. 4-40).

⑤

Pin Number	Signal	Pin Number	Signal
1	I/OAD2	2	DMON-N
3	I/OAD1	4	DCOFF1-P
5	I/OAD0	6	DMCLK
7	I/ODATA3	8	ACVON-N
9	I/ODATA2	10	CHVON-N
11	I/ODATA1	12	PWMON-N
13	I/ODATA0	14	CBVPWM-N
15	LEDON-N	16	DBV(MC) PWM-N
17	DMRDY-N	18	DBV(KY) PWM-N
19	I/ODATA4 (REV11)	20	FCBVPWM-N
21	PKCLL2ON-P	22	THVRON-N
23	AC_DCON-N	24	THVPWM-N
25	PKCLL1ON-P	26	THV-I
27	ELON-P	28	TH2
29	PBSEN-N	30	TH1
31	HPSEN-N	32	OILLES-P
33	CTFANON-P	34	FUTEMP
35	HTFANON-P	36	HON-N
37	+5v-1R	38	ACOFF-P
39	SGND	40	ACSYNC-N
41	SGND	42	+24
43	SGND	44	PGND
45	+5v-1	46	PGND
47	+5v-1	48	+24v-1
49	+5v-1D	50	+24v-1

4.6.4.2.6 IOD1 P.W.B. DCN10 IOD2 P.W.B ECN2 (10 pins)
IOD1 DCN10 IOD2 ECN2 (see Fig. 4-40).

⑥

Pin Number	Signal
1	+24v-1
2	+24v-1
3	+24v-1
4	PGND
5	PGND
6	PGND
7	+5v-1
8	SGND
9	SGND
10	+5v-D

4.6.4.2.7 IOD1 P.W.B. Upper Paper Empty Sensor (PSU)
Paper Feed Sensor (PT1) Drum Encoder Sensor (EN) OHP
Sensor (OHP) DCN4 PT1 OHP (see Fig. 4-40).

⑦

Pin Number	Signal	Pin Number	Signal
1	+5v-D	2	HPSEN-N
3	SGND	4	+5v-D
5	PT1-N	6	SGND
7	+5v-D	8	PEU-P
9	SGND	10	+5v-D
11	OHPSENU	12	SGND
13	SGND		

4.6.4.2.8 IOD1 P.W.B. Upper Paper Size Sensor
DCN6 (see Fig. 4-40).

⑧

Pin Number	Signal
1	+5v-D
2	PSU1
3	PSU2
4	PSU3
5	PSU4
6	PSU5
7	SGND

4.6.4.2.9 IOD1 P.W.B. Toner Empty Sensor (Y,M,C,K)
Erase Lamp, DCN7. (see Fig. 4-40).

⑨

Pin Number	Signal	Pin Number	Signal
1	TLES(K)-P	2	TLES(Y)-P
3	TLES(M)-P	4	TLES(C)-P
5	TLES-G	6	SGND
7	LEDON-P	8	TLESCHK
9	SGND	10	+24V-1
11	ELON-N		

4.6.4.2.10 IOD1 P.W.B. Controller Fan
DCN18 (see Fig. 4-40).

⑩

Pin Number	Signal
1	CTFANON-P
2	PGND
3	CTFANERR

4.6.4.2.11 IOD1 P.W.B. DCN8 Lower Paper Feeder Unit
IOD1 P.W.B. DCN8 (see Fig. 4-40).

⑪

Pin Number	Signal	Pin Number	Signal
1	+24v-1	2	PKCLL1ON-N
3	FDCLL1ON-N	4	PSL1
5	PSL2	6	PSL3
7	PSCST1	8	PEL1-P
9	OCST1-N	10	OHPSENL1
11	+5v-D	12	SGND
13	CASTDOPEN-N	14	+24v-1
15	PKCLL2ON-N	16	FDCLL2ON-N
17	PSL4	18	PSL5
19	PSL6	20	PSCST2
21	PEL2-P	22	OCST2-N
23	PHPSENL2	24	+5v-D
25	SGND	26	NC

4.6.4.2.12 IOD1 P.W.B.

DCN14 Heater Fan (HTFAN), Paper Exit Sensor (PT2),
Cleaning Roller Sensor (CRS), Paper Full Sensor (PFUL)
(see Fig. 4-40).

⑫

Pin Number	Signal	Pin Number	Signal
1	+5v-D	2	PT2-N
3	SGND	4	+5v-D
5	CLROL-N	6	SGND
7	+5v-D	8	PEFULL-N
9	SGND	10	HTFANON-P
11	PGND	12	HTFANERR

4.6.4.2.13 IOD1 P.W.B. DCN16 Belt Sensor, Oil Sensor,
Drum Jam Sensor
(see Fig. 4-40).

⑬

Pin Number	Signal
1	PBSEN-N
2	+5v-1
3	SGND
4	OILLES-P
5	+5v-1
6	SGND
7	PDSEN-N
8	+5v-D
9	SGND

4.6.4.2.14 MCTL P.W.B. 12CN1 IOD2 P.W.B. ECN1 (22 pins)
ECN1: MCTL IOD2 (22 26) (see Fig. 4-40).

⑭

Pin Number	Signal	Pin Number	Signal
1	DCL(C)ON-P	2	DCL(M)ON-P
3	DCL(Y)ON-P	4	DCL(K)ON-P
5	PSL(KY)ON-P	6	PSL(MC) ON-P
7	MMCLK	8	MMON-N
9	MMREV-N	10	MMENC
11	RECLON-P	12	AHUMB
13	ISCK	14	IDATA
15	ILOAD	16	FBCLON-P
17	FBSLON-P	18	TRSLON-P
19	OZFANON-P	20	FUCLON-P
21	PKCLU1ON-P	22	PKCLU2ON-P

4.6.4.2.15 IOD2 P.W.B. Developer Clutch (C)
ECN16 (see Fig. 4-40).

⑮

Pin Number	Signal
1	+24v-1
2	NC
3	DCL(C)ON-N

4.6.4.2.16 IOD2 P.W.B. Developer Clutch (M)
ECN15 (see Fig. 4-40).

⑯

Pin Number	Signal
1	+24v-1
2	NC
3	DCL(M)ON-N

4.6.4.2.17 IOD2 P.W.B Developer Clutch (Y)
ECN14 (see Fig. 4-40).

⑰

Pin Number	Signal
1	+24v-1
2	NC
3	DCL(Y)ON-N

4.6.4.2.18 IOD2 P.W.B. Developer Clutch (K)
ECN13 (see Fig. 4-40).

⑱

Pin Number	Signal
1	+24v-1
2	NC
3	DCL(K)ON-N

4.6.4.2.19 IOD2 P.W.B. ECN3 Home Position Sensor 1, Home Position Sensor 2, Developer Cam Clutch (YM), Developer Cam Clutch (CK), HP2, SLYM, SLCK.
(see Fig. 4-40).

①9

Pin Number	Signal	Pin Number	Signal
1	+5v-D	2	GHPSEN1-N (MC)
3	SGND	4	+5v-D
5	GHPSEN2-N (KY)	6	SGND
7	PSL(MC) ON-N	8	+24v-1
9	+24v-1	10	PSL(KY) ON-N
11	NC		

4.6.4.2.20 IOD2 P.W.B. Fuser Clutch
ECN9 (see Fig. 4-40).

②0

Pin Number	Signal
1	+24v-1
2	NC
3	FUCLON-N

4.6.4.2.21 IOD2 P.W.B. Cleaner Clutch
ECN11 (see Fig. 4-40).

②1

Pin Number	Signal
1	+24v-1
2	NC
3	FBCLON-N

4.6.4.2.22 IOD2 P.W.B. Ozone Fan
ECN5 (see Fig. 4-40).

②②

Pin Number	Signal
1	OZFANON-P
2	PGND
3	OZFANERR

4.6.4.2.23 IOD2 P.W.B. Registration Clutch
ECN6 (see Fig. 4-40).

②③

Pin Number	Signal
1	+24v-1
2	NC
3	RECLON-N

4.6.4.2.24 IOD2 P.W.B. Waste Toner Sensor
ECN17 (see Fig. 4-40).

②④

Pin Number	Signal
1	TBFL1-N
2	SGND
3	WTLEDON
4	SGND

4.6.4.2.25 IOD2 P.W.B. Cleaner Cam Clutch
ECN10 (see Fig. 4-40).

②⑤

Pin Number	Signal
1	+24v-1
2	NC
3	NC
4	FBSLON-N

4.6.4.2.26 IOD2 P.W.B. Transfer Cam Clutch
ECN8 (see Fig. 4-40).

②6

Pin Number	Signal
1	+24v-1
2	NC
3	NC
4	TRSLON-N

4.6.4.2.27 IOD2 P.W.B. Paper Feeding Clutch
ECN4 (see Fig. 4-40).

②7

Pin Number	Signal
1	+24v-1
2	NC
3	PKCLU1ON-N

4.6.4.2.28 IOD2 P.W.B. Main Motor
ECN12 (see Fig. 4-40).

②8

Pin Number	Signal
1	MMRDY-N
2	MMON-N
3	MMCLK
4	PGND
5	+24v-1
6	SGND
7	+5v-1
8	MMENC
9	MMREV-N

4.6.4.2.29 IOD1 P.W.B. Developer Motor
DCN9 (see Fig. 4-40).

②9

Pin Number	Signal
1	DMRDY-N
2	DMON-N
3	DMCLK
4	PGND
5	PGND
6	+24v-1
7	+24v-1
8	SGND
9	+5v-1

4.6.4.2.30 MCTL P.W.B. I3CN IOD1 P.W.B DCN13
I3CN MCTL IOD1(10 26) (see Fig. 4-40).

③0

Pin Number	Signal
1	TMLEDON-P
2	TMASEN1
3	TMSOLON-P
4	TMASEN2
5	SIN2 (REV12)
6	TMSOLERR
7	SOUT2(REVO1)
8	DCOFF2-N(REVO2)
9	FDCLL1ON-P(REV03)
10	FDCLL2ON-P(REV04)

4.6.4.2.31 MCTL P.W.B. LCN LDU P.W.B. (20 pins)
LCN MCTL LDU(20 26) (see Fig. 4-40).

③①

Pin Number	Signal	Pin Number	Signal
1	+5v-1R	2	LDREF2
3	LDREF3	4	+5v-1
5	LDREF1	6	LDREF0
7	LREADY	8	LCONT2
9	LCONT1	10	VIDEO-P
11	VIDEO-N	12	BDT-P
13	BDT-N	14	SGND
15	SGND	16	SCMCLK
17	SCMRDY-N	18	SCMON-N
19	PGND	20	+24v-1

4.6.4.2.32 Power Supply Unit ACN3 MCTL P.W.B. POCN
ACN3 (see Fig. 4-40).

③②

Pin Number	Signal
1	+5v-2
2	+5v-2D
3	+5v-2D
4	SGND
5	SGND
6	SGND

4.6.4.2.33 Power Supply Unit Interlock Switch
ACN2 (see Fig. 4-40).

③③

Pin Number	Signal
1	DSW-O
2	DSW-I

4.6.4.2.34 High-Voltage Unit BCN2 Fuser Unit
BCN2 (see Fig. 4-40).

③4

Pin Number	Signal
1	TH1
2	TH2
3	FUTEMP
4	FUCHKGND

4.6.4.2.35 MCTL P.W.B PACN PANEL P.W.B. (16 pins)
PACN MCTL PANEL(16 26) (see Fig. 4-40).

③5

Pin Number	Signal	Pin Number	Signal
1	PAI/ODATA0	2	PAI/ODATA1
3	PAI/ODATA2	4	PAI/ODATA3
5	PAI/ODATA4	6	PAI/ODATA5
7	PAI/ODATA6	8	PAI/ODATA7
9	LCDRS	10	LCDE
11	PASWRDN	12	PALEDWRN
13	SGND	14	+5v-1
15	LCDBLED	16	NC

4.6.4.2.36 CNDUP PRINTER Duplexer (24 pins)
(see Fig. 4-40).

③⑥

Pin Number	Signal	Pin Number	Signal
1	D-COMMAND	2	SGND
3	DUMBUSY2-N	4	SGND
5	D-STATUS	6	SGND
7	+24vOFF-P	8	DUPCHK-N
9	DUMBUSY1-N	10	PT-1
11	DUPRES-N	12	SGND
13	NC	14	NC
15	PGND	16	PGND
17	+24v-2	18	+24v-2
19	+5v-1D	20	SGND
21	+5v-1	22	NC
23	NC	24	NC

4.6.4.2.37 IOD1 P.W.B. Toner Key Sensor
DCN15 (see Fig. 4-40).

③⑦

Pin Number	Signal
1	TONEROK-N
2	NC
3	SGND

4.6.4.2 Duplexer Wiring Diagram

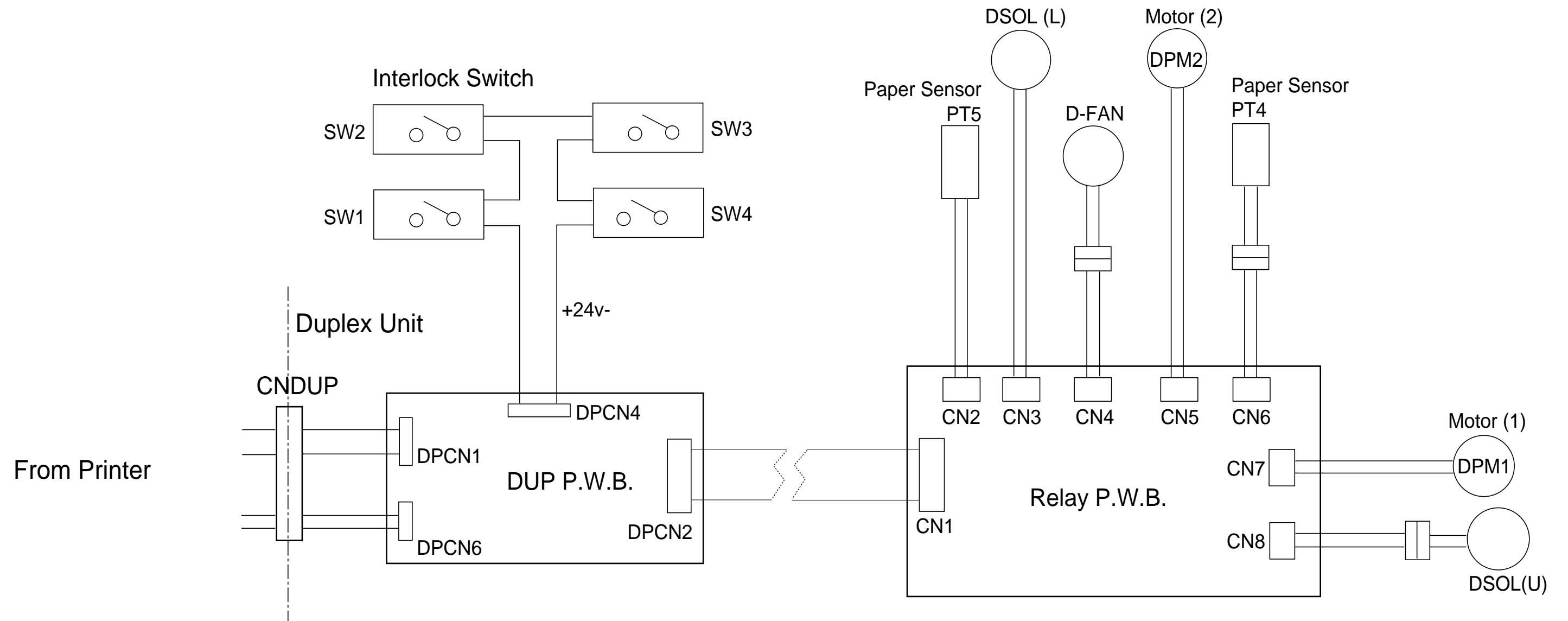

Fig. 4-41

4.6.4.3 Pin Assignments for Duplexer Unit

4.6.4.3.1 CNDUP

PRINTER Duplexer (24 pins) (see Fig. 4-41).

Pin Number	Signal	Pin Number	Signal
1	D-COMMAND	2	SGND
3	DUMBUSY2-N	4	SGND
5	D-STATUS	6	SGND
7	+24vOFF-P	8	DUPCHK-N
9	DUMBUSY1-N	10	PT-1
11	DUPRES-N	12	SGND
13	NC	14	NC
15	PGND	16	PGND
17	+24v-2	18	+24v-2
19	+5v-1D	20	SGND
21	+5v-1	22	NC
23	NC	24	NC

4.6.4.3.2 CN1: DUP Relay P.W.B.

(see Fig. 4-41).

Pin Number	Signal	Pin Number	Signal
1	PGND	2	+24v-1
3	SGND	4	+5v-1
5	DPFANERR	6	DPFULLSK
7	PT-4	8	DPFANON-P
9	OUT1-1A	10	DPSLON-N
11	OUT1-1B	12	OUT1-2A
13	REVO1	14	OUT1-2B
15	+5v-1	16	REV11
17	PT-5	18	SGND
19	OUT2-2A	20	OUT2-1A
21	OUT2-2B	22	OUT2-1B

4.6.4.3.3 CN2: PAPER SENSOR PT4
(see Fig. 4-41).

Pin Number	Signal
1	+5v-1
2	PT-4
3	SGND

4.6.4.3.4 CN3: DSOL (L)
(see Fig. 4-41).

Pin Number	Signal
1	+24v-1
2	DPSL2ON-N

4.6.4.3.5 CN4: DFAN
(see Fig. 4-41).

Pin Number	Signal
1	DPFANON-P
2	DPFANERR
3	PGND

4.6.4.3.6 CN5: Motor (1)
(see Fig. 4-41).

Pin Number	Signal
1	OUT1-1B
2	OUT1-1A
3	OUT1-2A
4	OUT1-2B

4.6.4.3.7 CN6: Sensor (PT5)
(see Fig. 4-41).

Pin Number	Signal
1	+5v-1
2	PT-5
3	SGND

4.6.4.3.8 CN5: Motor (2)
(see Fig. 4-41).

Pin Number	Signal
1	OUT2-2B
2	OUT2-1A
3	OUT2-2A
4	OUT2-2B

4.6.4.3.9 CN3: DSOL (U)
(see Fig. 4-41).

Pin Number	Signal
1	OUT1
2	OUT2

4.6.4.4 LFU Wiring Diagram

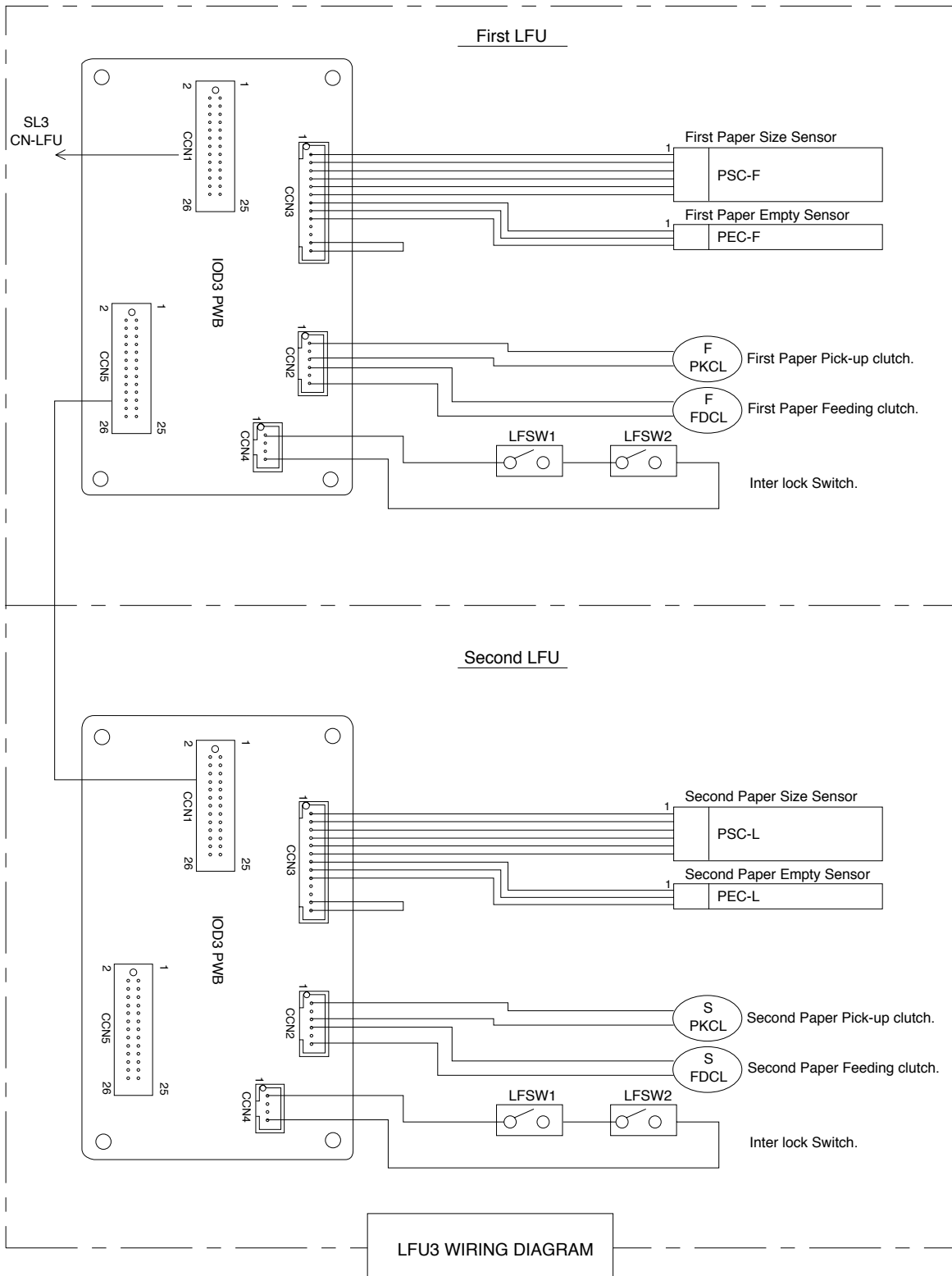

4.6.4.5 IOD3 P.W.B Pin Assignment

4.6.4.5.1 CCN1 - IOD3 (Upper)

Pin Number	Signal	Pin Number	Signal
1	+24v-1	2	PKCLL1ON-N
3	FDCLL1ON-N	4	PSL1
5	PSL2	6	PSL3
7	PSCST1 (PSL5)	8	PEL1-P
9	OCST1-N	10	OHPSENL1
11	+5v-D	12	SGND
13	CASTDOPEN-N	14	+24v-1
15	PKCLL2ON-N	16	FDCLL2ON-N
17	PSL4 (PSLL1)	18	PSL5 (PSLL2)
19	PSL6 (PSLL4)	20	PSCST2 (PSLL5)
21	PEL2-P	22	OCST2-N
23	OHPSENL2	24	+5v-D
25	SGND	26	NC

4.6.4.5.2 CCN2 : IOD3 - Paper Pick-up Clutch

Pin Number	Signal
1	PKCLL1ON-N
2	NC
3	+24v-1DSW
4	+24v-1DSW
5	NC
6	FDCLL1ON-N

4.6.4.5.3 CCN3: IOD3 - Cassette Paper Size Sensor

Pin Number	Signal	Pin Number	Signal
1	+5v-D	2	PSL1
3	PSL2	4	PSL3
5	PSCST1 (PSL5)	6	SGND
7	+5v-D	8	PEL1-P
9	SGND	10	+5v-D
11	NC	12	SGND
13	OCST1-N		

4.6.4.5.4 CCN4: IOD3 (Upper) - Door Switch

Pin Number	Signal
1	DSWOUT (+24v-1)
2	NC
3	NC
4	DSWIN

4.6.4.5.5 CCN5 - IOD3 (Upper) - IOD3 (Lower)

Pin Number	Signal	Pin Number	Signal
1	+24v-1	2	PKCLL2ON-N
3	FDCLL2ON-N	4	PSL4 (PSLL1)
5	PSL5 (PSLL2)	6	PSL6 (PSLL4)
7	PSCST2 (PSLL5)	8	PEL2-P
9	OCST2-N	10	OHPSEN2
11	+5v-D	12	SGND
13	CASTDOPEN-N	14	NC
15	NC	16	NC
17	NC	18	NC
19	NC	20	NC
21	NC	22	NC
23	NC	24	NC
25	NC	26	NC

Section 5:
Periodic Maintenance

5.0 Periodic Maintenance

5.1 General

5.1.1 Handling Precautions

The laser printer is a piece of precision equipment. Daily inspection and periodic maintenance is indispensable to maintain high printing performance.

The following list of important precautions and action items pertain to maintenance and the periodic replacement of parts:

- Refrain from any operation, disassembly, or modifications that are not set out in this manual.
- Turn off the power and unplug the power cord prior to assembling or disassembling the printer.
- Whenever replacing any parts, confirm the replaced parts are in place prior to starting the printer.
- Adhere to any precaution or warning labels affixed to a printer component.
- Unless otherwise specified, precisely follow the reverse order of the disassembly procedures for re-assembly. Do not confuse different screw types and length.
- Do not use any solvent for cleaning the inside or outside of the printer.
- Do not dispose of waste toner with flammable substances. Do not throw toner into a fire.

5.1.1.1 List of Maintenance Tools

Table 5-1 below lists the maintenance tools for the printer.

Table 5-1

No.	Tool	Function
1	Phillips Screwdriver #1	For M3
2	Phillips Screwdriver #2	For M4
3	Phillips Screwdriver (short shank) #2	For M4
4	Slotted Screwdriver #1	For slotted screws
5	Slotted Screwdriver #2	For slotted screws
6	Needle-Nose Pliers	For general use
7	Precision Driver Set (#1 ~ #6)	For general use
8	Pliers for C Ring	Removal of C Rings
9	Ruler (150mm)	For general use
10	Digital Multimeter	For general use
11	Toner Cleaner	For cleaning
12	Soft Bristle Brush	For cleaning

5.1.1.2 List of Consumables for Maintenance

Table 5-2 below lists recommended consumables for maintenance.

Table 5-2

No.	Consumable	Quantity	Function
1	Toner Cartridge (Y)	1	Test Print
2	Toner Cartridge (M)	1	Test Print
3	Toner Cartridge (C)	1	Test Print
4	Toner Cartridge (K)	1	Test Print
5	Cleaning Roller/Oil Bottle	1	Test Print
6	OPC Belt Cartridge	1	Test Print
7	Recommended Paper	5	Test Print
8	Recommended OHP	2	Test Print
9	Lint Free Cotton Cloth	10 ~ 15	Cleaning
10	Cotton Swab	10 ~ 15	Cleaning
11	Molybdenum Grease	10g	M.G. 1PS265
12	Vinyl Bag	2	Disposal

5.2 Cleaning for Periodic Maintenance

See Table 5-3 for details of periodic maintenance cleaning to the following parts.

- Registration Roller
- Transfer Roller
- Paper Discharger
- Belt Cartridge
- Dustproof Glass of Optical Unit
- Printer Interior

WARNING

Before starting any maintenance work, unplug the power supply cord from the outlet.

There is a risk of electric shock if working while the printer is plugged in.

5.2.1 Periodic Maintenance Cleaning Cycle Table

Table 5-3

Part	Description	Ref. Page	Cleaning Cycle	Time ^a	Skill Level ^b
Registration Roller	<ol style="list-style-type: none"> 1. Open the transfer unit. 2. Clean the rollers using a dry cloth 	5-5	<ul style="list-style-type: none"> • Defective image • Smearred paper • Periodic maintenance 	2	A, B, or User
Transfer Roller	<ol style="list-style-type: none"> 1. Open the transfer unit. 2. Clean the rollers using a dry cloth. 	5-6	<ul style="list-style-type: none"> • Defective image • Smearred paper • Periodic maintenance 	2	A, B, or User
Paper Discharger	<ol style="list-style-type: none"> 1. Open the transfer unit. 2. Remove the paper discharger. 3. Clean the corona wire and case, using a cotton swab and dry cloth. 	5-7	<ul style="list-style-type: none"> • Defective image • Paper Jam • Periodic maintenance 	3	A, B, or User
Belt Cartridge	<ol style="list-style-type: none"> 1. Remove the belt cartridge. 2. Clean toner from the belt cartridge and cleaning blade. 3. Clean the corona wire with the brush. 	5-8	<ul style="list-style-type: none"> • Defective image quality • Periodic maintenance 	3	A, B, or User
Dustproof Glass (Optical Unit)	<ol style="list-style-type: none"> 1. Remove the toner cartridges. 2. Remove the belt cartridge. 3. Remove the dust-proof glass. 4. Clean the dust-proof glass with a dry cloth and cotton swab. 	5-9	<ul style="list-style-type: none"> • Defective image quality • Periodic maintenance 	3	B or C
Printer Interior	<ol style="list-style-type: none"> 1. Remove the toner cartridges and belt cartridge. 2. Clean the printer's base, using cleaner and dry cloth. 	5-10	<ul style="list-style-type: none"> • Defective image quality • Periodic maintenance 	5	B or C

a. Normal time (in minutes) for replacement of noted parts.

b. Technical level required for maintenance or replacement: A: Beginner; B: Experienced; C: Expert.

5.2.2 Periodic Maintenance Cleaning Procedures

5.2.2.1 Cleaning of Registration Roller

The Registration Roller should be cleaned according to the periodic maintenance cleaning cycle presented in Table 5-3.

Tools:

Lint-free cotton cloth (2 ~ 3 pieces)

Cleaning Procedures (see Fig. 5-1 and Fig. 5-2):

1. Turn off the power supply, and unplug the power cord.
2. Open the transfer unit.
3. Using a clean, lint-free cloth, clean the registration roller incorporated in the transfer unit.

CAUTION

Do not use alcohol or other solvents for cleaning the registration roller.

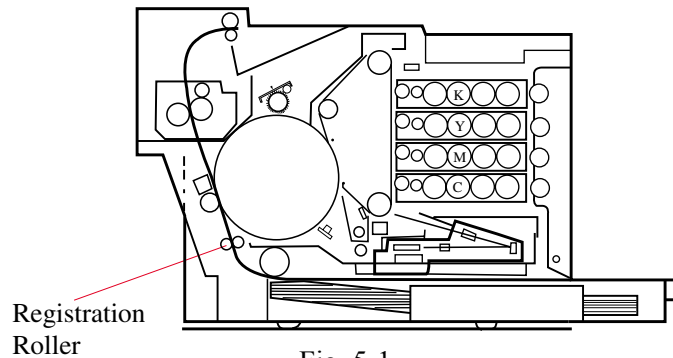

Fig. 5-1

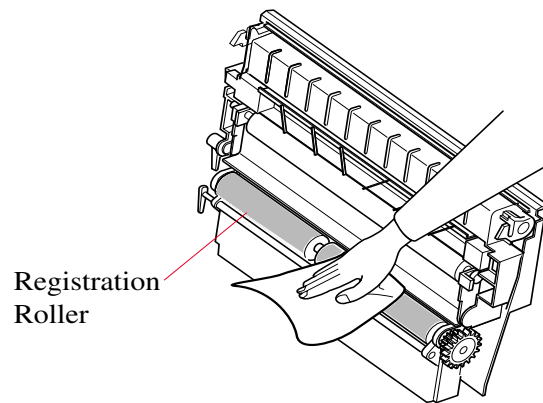

Fig. 5-2

5.2.2.2 Cleaning of the Transfer Roller

Transfer Roller should be cleaned according to the periodic maintenance cleaning cycle set out in Table 5-3.

Tools:

Lint-free cotton cloth (2 ~ 3 pieces)

Cleaning Procedures (see Fig. 5-3 and Fig. 5-4):

1. Turn off the power supply, and unplug the power cord.
2. Open the transfer unit.
3. Using a clean, lint-free cloth, clean the transfer roller.

CAUTION

Strictly refrain from using alcohol or other solvents for cleaning the transfer roller.

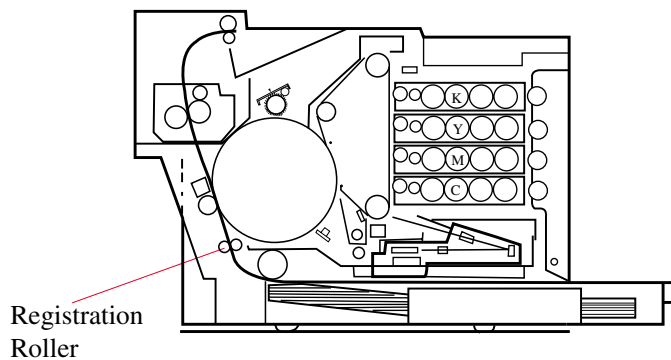

Fig. 5-3

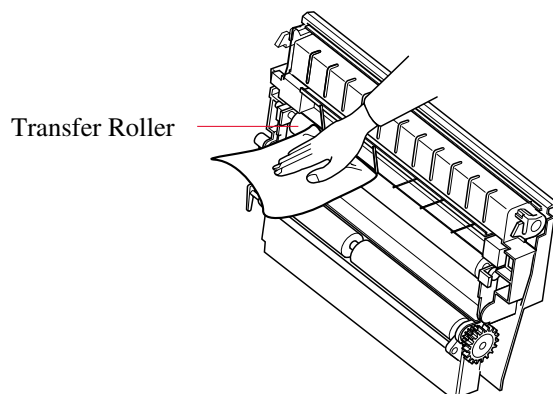

Fig. 5-4

5.2.2.3 Cleaning of the Paper Discharger /AC Charger

Paper Discharger should be cleaned according to the periodic maintenance cleaning cycle set out in Table 5-3.

Tools:

1. Lint-free cotton cloth (2 ~ 3)
2. Cotton swab (2 ~ 3).

5.2.2.4 Cleaning Procedures (see Fig. 5-5 and Fig. 5-6):

1. Turn off the power supply switch, and unplug the power cord.
2. Open the transfer unit.
3. Remove the paper discharger unit.

- a. Slide the AC charger in the direction of the arrow, and release it from the locking tab.
- b. Pull up the AC charger, and remove it from the transfer unit holder.

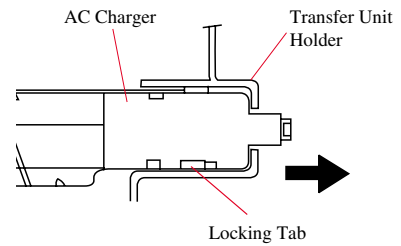

Fig. 5-5

4. Clean the charger case with a cotton cloth.
5. Clean the charger wire and inside of charger case with a cotton swab.
6. Install the charger unit in the transfer unit.

CAUTION

Do not cut the corona wire when cleaning the discharger unit.

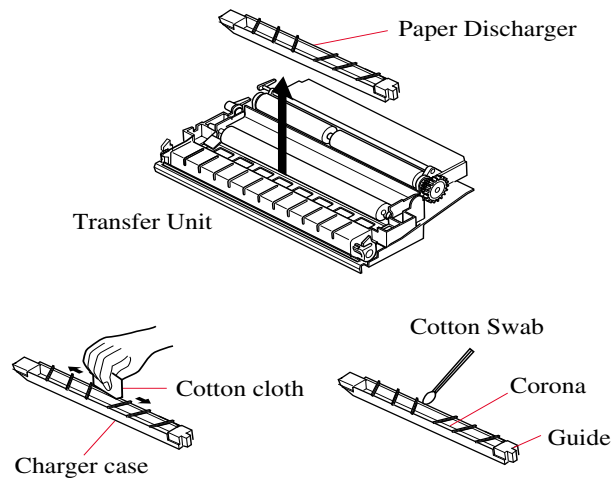

Fig. 5-6

5.2.2.5 Cleaning of the Belt Cartridge

Belt Cartridge shall be cleaned according to the periodic maintenance cleaning cycle presented in Table 5-3.

WARNING

Do not expose the OPC belt to light of more than 800 Lux (ordinary office light) for more than two minutes. Do not touch the surface of the OPC belt.

Supplies:

1. Lint-free cotton cloth (2 ~ 3)

Cleaning Procedures (see Fig. 5-7):

1. Turn off the power supply switch.
2. Open the top door.
3. Open the front door.
4. Release the belt cartridge lock levers.
5. Pull out the belt cartridge.
6. Clean the belt cartridge with a cotton cloth.
 - a. Clean the rear side of the belt cartridge.
 - b. Clean the corona wire with the wire brush. Slide the brush in the direction of the arrow several times.
 - c. Clean the belt cartridge case.

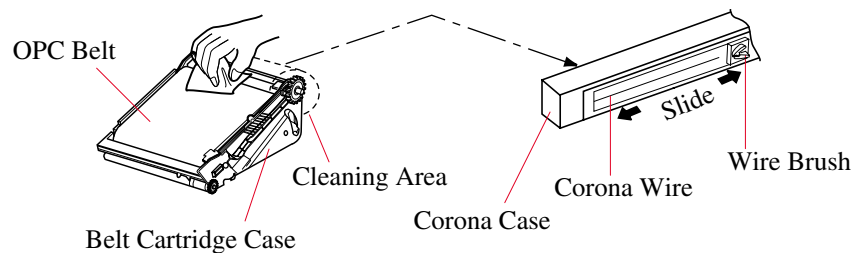

Fig. 5-7

5.2.2.6 Cleaning of the Dustproof Glass in the Optical Unit

The dustproof Glass of the Optical Unit should be cleaned according to the periodic maintenance cleaning cycle presented in Table 5-3.

Pay strict attention to the information on the laser WARNING label found on the laser unit (see Fig. 5-8).



Fig. 5-8

Supplies:

1. Lint-free cotton cloth (2 ~ 3)
2. Cotton swab (2 ~ 3).

Cleaning Procedures (see Fig. 5-9):

1. Turn off the power supply switch.
2. Open the top and front doors.
3. Remove the toner cartridges and the belt cartridge.
4. Open the shield on the dustproof glass covering the optical unit.
5. Clean the surface of the dustproof glass with a cotton swab or clean, lint-free cloth.
6. Lock the cover back over the dust-proof glass in the optical unit.

CAUTION

Do not use alcohol or other solvents for cleaning the dustproof glass. This will cause poor image quality.

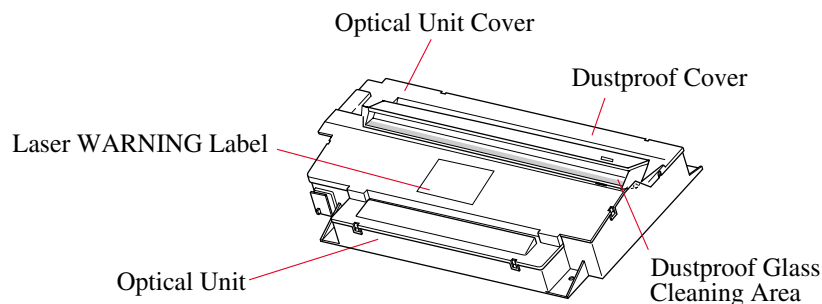

Fig. 5-9

5.2.2.7 Cleaning of the Printer Interior

The Printer Interior (bottom) should be cleaned according to the periodic maintenance cleaning schedule presented in Table 5-3.

CAUTION

Before cleaning the inside of printer, protect the transfer drum with paper so that the nozzle of the vacuum will not touch the transfer drum.

Tools and Supplies:

1. Toner Vacuum
2. Lint-free cotton cloth (2 ~ 3)

Cleaning Procedures (see Fig. 5-10):

1. Open the top door.
2. Open the front door.
3. Remove the toner cartridges.
4. Remove the OPC belt cartridge.
5. Vacuum the toner from the printer base with a toner vacuum.
6. Clean the printer interior with a lint-free cloth.
7. Reinstall the consumables.

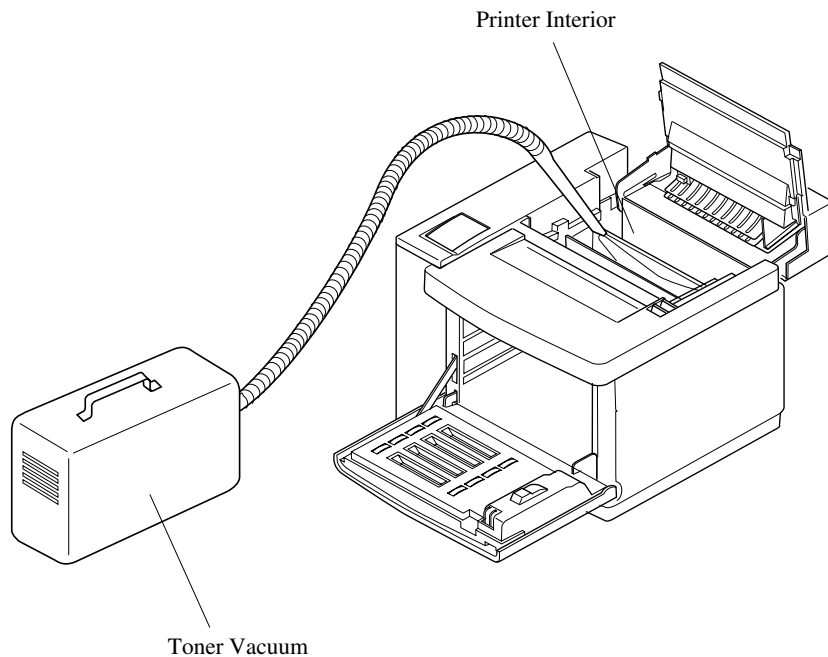

Fig. 5-10

5.3 Periodic Maintenance Cycles and Procedures

5.3.1 Periodic Maintenance Parts and Maintenance Cycle

Maintenance should be performed according to the information presented in Table 5-4.

Table 5-4: Periodic Maintenance Schedule

Part	Description	Sect.	Replacement Cycle ^a	Time ^b	Skill Level ^c
Fuser	To fix toner on a sheet of paper.	5.3.3	100K prints (Maintenance Code: "REPLACE FUSER" or C:FU)	4	A or B
OPC Belt Cartridge	To form an electrostatic latent image.	5.3.2	120K planes (Maintenance Code: "REPLACE BELT" or C:BC)	4	A or B
Transfer Roller	To transfer toner image from the transfer drum to a sheet of paper.	5.3.4	240K prints (Maintenance Code: "120K CHECKUP" or C:OW)	3	A or B
Paper Discharger	To separate paper from transfer drum.	5.3.5	120K prints (Maintenance Code: "120K CHECKUP" or C:OW)	2	A or B
Drum Cleaner	To clean residual toner from transfer drum.	5.3.6	240K prints (Maintenance Code: "120K CHECKUP" or C:OW)	2	A or B
Ozone Filter	To absorb ozone.	5.3.7	Every 12 months.	1	A or B
Paper Feeding Roller	To individually pick up paper from the paper cassette.	5.3.8	120K prints (No maintenance code)	20	B or C
Transfer Drum	To form the toner image and transfer it onto paper.	5.3.9	600K images (No maintenance code)	20	B or C

a. After completion of maintenance, clear the maintenance code displayed on the operator panel.

b. Normal time required for replacement of specific parts.

c. Technical level required for replacement and maintenance (A: Beginner; B: Experienced; C: Expert).

Table 5-5: Maintenance Codes

OEM Error Code	QMS Error Code	Explanation
C: F0	FUSER OIL EMPTY	Fuser Oil is empty.
C: FC	CHECK CLEANING ROLLER	Fuser Cleaning Roller should be replaced.
C: YT	YELLOW TONER EMPTY	Yellow Toner is empty.
C: MT	MAGENTA TONER EMPTY	Magenta Toner is empty.
C: CT	CYAN TONER EMPTY	Cyan Toner is empty.
C: KT	BLACK TONER EMPTY	Black Toner is empty.
C:BC	REPLACE BELT	Belt Cartridge should be replaced.
C: FU	REPLACE FUSER	Fuser should be replaced.
C: OW	120K CHECKUP	120K Page Maintenance Required
C: TD	120K CHECKUP	Transfer Drum should be replaced.
C: WT	CHECK WASTE TONER	The Waste Toner bottle is nearly full and should be replaced.
C: SF	OUTPUT BIN FULL	The output bin is nearly full and should be emptied.
C: PK	120K CHECKUP	120K Page Maintenance Required
C: P1	120K CHECKUP	120K Page Maintenance Required
C: P2	120K CHECKUP	120K Page Maintenance Required
C: PD	120K CHECKUP	120K Page Maintenance Required

5.3.2 Replacement of the OPC Belt Cartridge

5.3.2.1 Criterion of Replacement

The OPC Belt Cartridge should be replaced with a new cartridge at 120,000 pages or 12 months, whichever comes earlier. When the time is due for replacement of the OPC belt cartridge, the warning code “REPLACE BELT” appears on the operator panel.

CAUTION

Do not directly touch the OPC belt surface.

Do not expose the belt to room light for more than two minutes.



5.3.2.2 Procedure of Replacement (see Fig. 5-11 through Fig. 5-16).

1. Turn the power switch off.
1. Open the front door.
1. Open the top door.

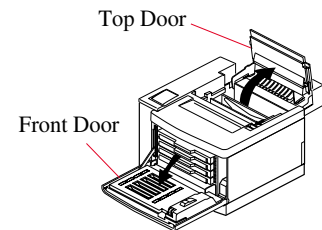
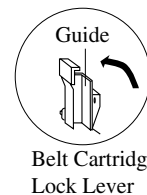

Fig. 5-11

1. Unlock the belt cartridge lock lever on both sides (left and right).



Belt Cartridge Lock Lever

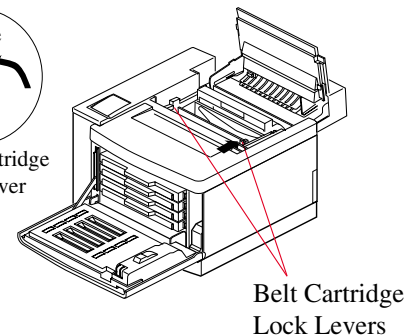

Fig. 5-12

1. Pull out the belt cartridge.

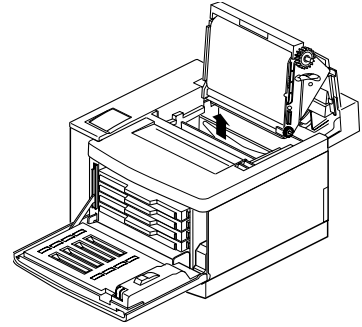

Fig.5-13

1. Prepare a new belt cartridge.
 - a. Pull out and remove the tension release pin.
 - b. Remove the protective sheet.

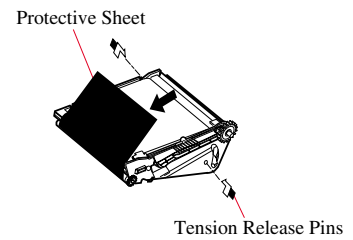

Fig. 5-14

1. Push the new belt cartridge along the guides into the printer body.

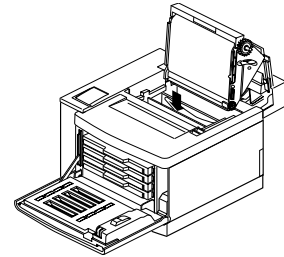

Fig. 5-15

1. Set the belt cartridge lock lever on both sides (left and right).
1. Close the front door.
1. Close the top door.
1. Turn the power switch on.
1. Clear the REPLACE BELT error via the Service Mode CLEAR CARE mode, or the ADMINISTRATION/CONSUMABLES/ITEM REPLACED menu.
1. The error message resets, and the warming-up process starts.

5.3.3 Replacement of the Fuser (see Fig. 5-17 through Fig. 5-19)

5.3.3.1 Criterion of Replacement

The fuser should be replaced with a new unit according to the periodic maintenance cycle set out in the Table 5-4. When it is time to replace the fuser, the warning code “REPLACE FUSER” appears on the LCD of the operator panel.

5.3.3.2 Purpose of Replacement

To prevent the print quality from declining due to the deterioration of fuser's roller.

5.3.3.3 Precaution

(see Fig. 5-16)

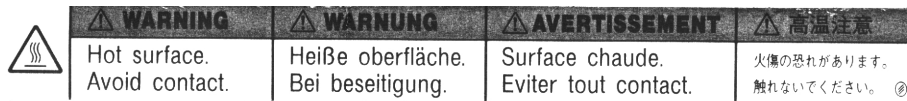

Fig. 5-16

WARNING

Allow the fuser to cool before performing this procedure.

5.3.3.4 Tools and Supplies:

1. Fuser
1. Lint-free cotton cloth (2 ~ 3)

5.3.3.5 Procedures

5.3.3.5.1 Fuser Removal Procedures:

1. After turning off the power switch, unplug the power cord from the outlet.
2. Open the paper exit unit.
3. Remove the two thumbscrews from the fuser (see Fig. 5-17).

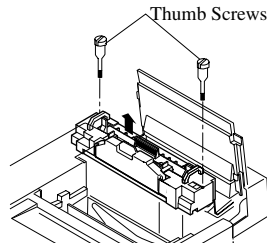

Fig. 5-17

4. Holding the handle provided on each side of the fuser, remove the fuser.

CAUTION

When removing the fuser, keep it level so that oil doesn't leak out. Use the siphon included with the cleaning roller to suck out all the remaining oil in the fuser. After siphoning, fill the oil pan with paper or tissue to ensure that no oil leaks out.

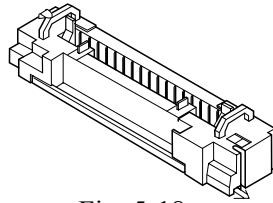

Fig. 5-18

5.3.3.5.2 Sequence of Replacement

1. Move the roller's tension-release levers in the direction indicated by the arrow.
2. Install the new fuser into the printer.

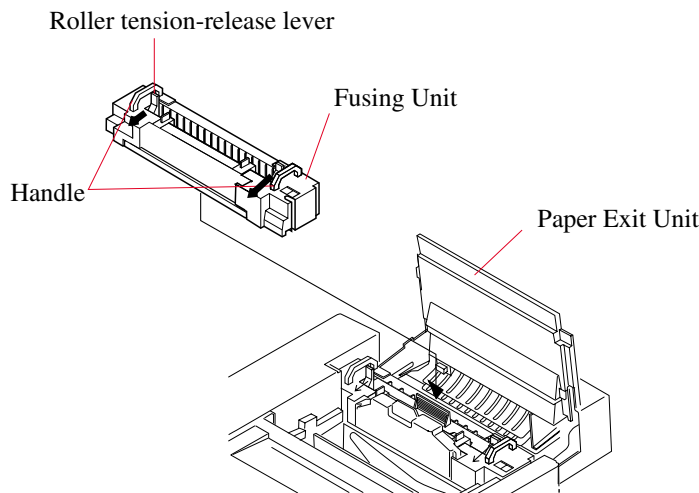

Fig. 5-19

3. Install the oil bottle and cleaning roller into the fuser.
 - a. After setting the fuser in place, lightly press down on the unit to firmly connect to the connector of base.
 - b. Secure the fuser with the thumbscrews.
4. After the warm-up process, clear the code "REPLACE FUSER" by the Service Mode "CLEAR CARE" mode or via

ADMINISTRATION/CONSUMABLES/ITEM
REPLACED/ FUSER.

5.3.4 Replacement of the Transfer Roller

5.3.4.1 Criterion of Replacement

The transfer roller should be replaced with a new transfer roller according to the periodic maintenance cycle set out in the Table 5-4. When it is time to replace the transfer roller, the warning code “120K CHECKUP” will appear in the operator panel.

5.3.4.2 Purpose of Replacement

To prevent image degradation due to the deterioration of the transfer roller.

5.3.4.3 Tools and Supplies:

1. Lint-free cloth.
1. Transfer unit (one)

5.3.4.4 Procedures

5.3.4.4.1 Sequence of Disassembling

1. After turning off the power, remove the power cord from the outlet.
2. Open the transfer door.

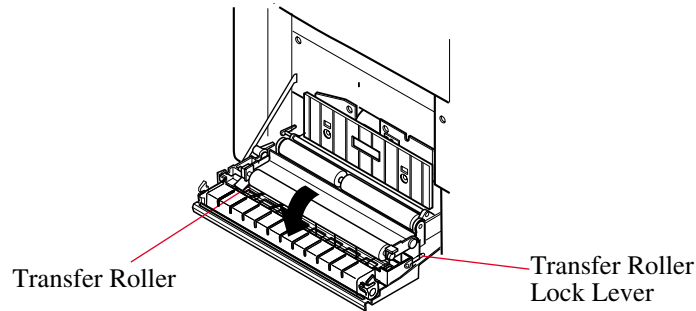

Fig. 5-20

5.3.4.4.2 Procedures of Replacement

1. Move the two lock levers in the 'A' direction (see Fig. 5-22).
2. While holding the lock levers, pull up the transfer roller.

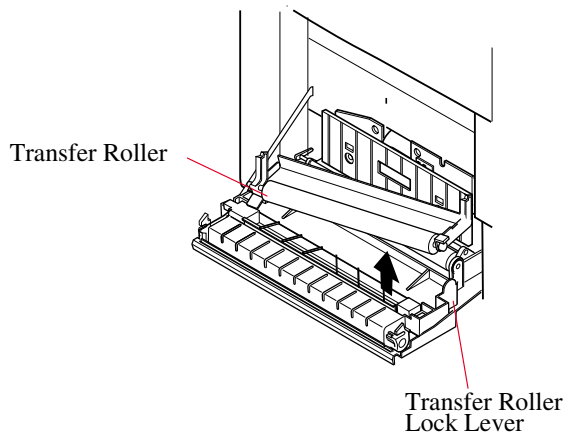

Fig. 5-21

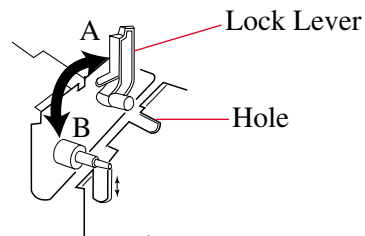

Fig. 5-22

5.3.4.4.3 Assembly Procedures

1. While holding the lock levers, align the shaft of both sides to the groove in the transfer base.
2. Press in the shaft of the transfer roller into the groove.
3. Move the lock lever in the 'B' direction, and secure the transfer roller (see Fig. 5-22).
4. Close the transfer door.
5. Plug the power cord in the outlet.
6. Push the power switch On.
7. Upon completion of warming-up, clear the code “120K CHECKUP” with Service Mode CLEAR CARE Mode or via “ADMINISTRATION/CONSUMABLES/PM SERVICE/120K PM SERVICE.”

5.3.5 Replacement of the Paper Discharger (see Fig. 5-23)

5.3.5.1 Criterion of Replacement

The paper discharger should be replaced with a new paper discharger according to the periodic maintenance cycle set out in the Table 5-4. When it is time to replace the paper discharger, a warning code “120K CHECKUP” will appear in the operator panel.

5.3.5.2 Purpose of Replacement

To prevent jamming due to deterioration of the paper discharger unit.

CAUTION

Do not touch the corona of the paper discharger unit.

5.3.5.3 Tools and Supplies:

1. Clean lint-free cloth (2 ~ 3)
2. Paper discharger (1)

5.3.5.4 Procedures

5.3.5.4.1 Disassembly Sequence

1. After turning the power off, disconnect the power cord from the outlet.
2. Open the transfer unit door.

5.3.5.4.2 Sequence of Replacement

1. Remove the paper discharger from the transfer unit.
2. Clean the area where the paper discharging unit will be mounted.
3. Install new paper discharger in the transfer unit (see Fig. 5-23).

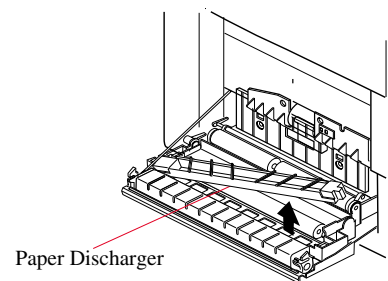

Fig. 5-23

5.3.5.4.3 Sequence of Assembly

1. Close the transfer unit door.
2. Upon completion of warming-up, clear the code “120K CHECKUP” with the Service Mode CLEAR CARE Mode or via “ADMINISTRATION/CONSUMABLES/PM SERVICE/120K PM SERVICE.”

5.3.6 Replacement of the Drum Cleaner
(see Fig. 5-24 through Fig. 5-26)

5.3.6.1 Criterion of Replacement

The drum cleaner should be replaced according to the periodic maintenance cycle set out in the Table 5-4. When it is time to replace the drum cleaner, a warning code “120K CHECKUP” will appear on the operator panel.

5.3.6.2 Purpose of Replacement

To prevent the cleaning efficiency from declining due to deterioration of the drum cleaner.

5.3.6.3 Tools and Supplies:

1. Clean lint-free cloth (2 ~ 3)
1. Drum cleaner (1)

5.3.6.4 Replacement Procedures

1. Turn off the power.
1. Open the top door.
1. Remove the cleaner cover (see Fig. 5-24).

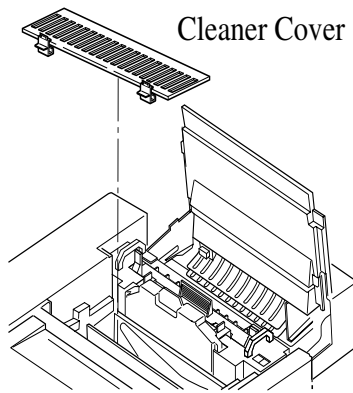

Fig. 5-24

1. Holding the knob and band located on the top of the drum cleaner, remove the drum cleaner. Pull both ends of the handle upward, and then remove the drum cleaner shaft from the bearing at the engine sides (see Fig. 5-25).

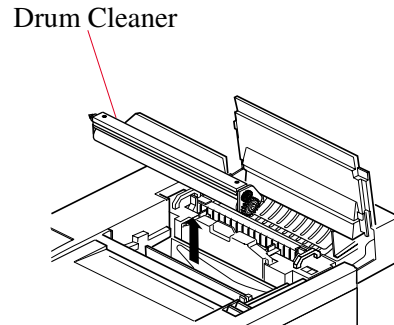

Fig. 5-25

2. Clean the area where the drum cleaner will be mounted.
3. Install a new drum cleaner in the printer (see Fig. 5-26). Push the drum cleaner into the printer, having both ends meet the bearing at the engine side.

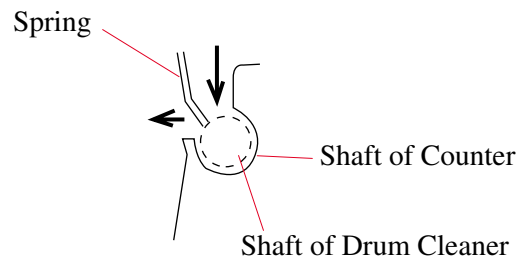

Fig. 5-26

4. Close the top door.
5. Turn on the power.
6. Upon completion of warming-up, clear the code "120K CHECKUP" with the Service Mode CLEAR CARE Mode or via "ADMINISTRATION/CONSUMABLES/PM SERVICE/120K PM SERVICE."

5.3.7 Replacement of the Ozone Filter (see Fig. 5-27)

5.3.7.1 Criterion of Replacement

The ozone filter should be replaced with a new filter according to the periodic maintenance cycle set out in the Table 5-4. This is to prevent ozone from being expelled due to the deterioration of the ozone filter.

CAUTION

The ozone filter should be replaced with a new filter every 12 months.

5.3.7.2 Tools and Supplies:

No special tools or equipment are necessary for the replacement of ozone filter.

5.3.7.3 Removal and Installation Procedures

1. Remove the ozone filter cover from the rear of the right side cover.
2. Remove the ozone filter from the ozone filter cover.
3. Install a new ozone filter in the filter cover.
4. Replace the new ozone filter cover.

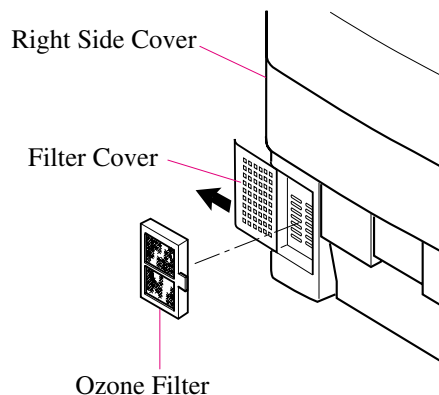

Fig. 5-27

5.3.8 Checking of the Paper Feeding Roller and Separator Pad

5.3.8.1 Replacement Criteria

Since the paper feeding roller and separator pad are defined as periodic replacement parts in Table 5-4, they should be replaced when frequent misfeed jams occur.

5.3.8.2 Replacement Procedures

1. Whenever frequent misfeed jams occur, confirm that the cause is the same as outlined in section 8.3, "Paper Transportation Errors."
1. If the feeding jam is caused by a paper feeding roller or separator pad, replace them according to the replacement procedures set out in section 7.6.4.

CAUTION

This procedure is a periodic replacement task, but it cannot be done by the customer. This should be done by a service technician upon request of the customer or at periodic maintenance.

After the replacement, confirm the feeding of media such as plain paper, OHP, and thick stock.

For proper performance of the optional lower feeding unit (LFU), the following parts should be replaced as noted.

Part Name	Part Code	Replacement Cycle
Paper Feeding Roller	825126142	Every 120k Prints
Separator Pad	825126528	Every 120k Prints

5.3.9 Replacement of the Transfer Drum

5.3.9.1 Replacement Criteria

Since the transfer drum is defined as a periodic replacement parts in Table 5-4, it should be replaced when a print quality failure occurs due to failed transfer drum. The warning code “TD” appears in the operator panel.

5.3.9.2 Replacement Procedures

1. Whenever the error occurs, confirm that the cause is the same as outlined in section 8.5 “Imaging Failures”.
1. If the failure is caused by the transfer drum, replace it according to the replacement procedures set out in the section 7.6.3.
1. Upon Completion of the warming-up process, clear the code “TD” by Service Mode CLEAR CARE mode.

CAUTION

This procedure is a periodic replacement task, but it cannot be done by the customer. This should be done by a service technician upon request of the customer or at periodic maintenance.

After the replacement, confirm the improvement of print quality by printing a test print.

Section 6:

Operation and Adjustments through the Operator Panel

6.0 Operation of and Adjustments through the Operator Panel

6.1 Panel Layout

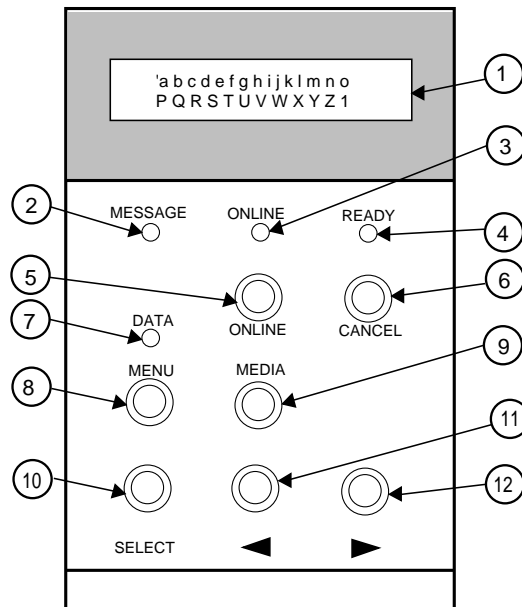

Fig. 6-1

Table 6-1

Number	Name of Key or Button
1	LCD: 16 characters by 2 lines
2	Message LCD
3	Online LCD
4	Ready LCD
5	Online Key
6	Cancel Key
7	Data LCD
8	Menu Key
9	Media key
10	Select Key
11	Scroll Key (Left)
12	Scroll Key (Right)

6.2 Display Modes

This printer has two modes (see Table 6-2 and Table 6-3) which allow for easy print engine operation status checks when performing maintenance.

6.2.1 Normal Mode

(see Table 6-2)

To provide the message indication function as to the drive status and the normal operation for which the operator is responsible.

Table 6-2: Normal Mode Messages²

Controller Message	MCTL Message ^a
IDLE	00 READY
WARMING UP	01 WAIT
INPUT IDLE PRINTING	02 PRINT
PUT "X" IN INPUT BIN or PUT "X" IN "Y" BIN ^b	CHK MEDIA TYPE
PUT "Z" IN INPUT BIN or PUT "Z" IN "Y" BIN ^c	NO MEDIA
ADJUST "INPUT" BIN	NO TRAY
OUTPUT BIN FULL	STACKER FULL
"COLOR ^d " TONER LOW or "COLOR" TONER EMPTY	REPLACE TONER
FUSER OIL LOW or FUSER OIL EMPTY	CHK FUSER OIL
CHECK CLEANING ROLLER	CHK CLEANING ROLLER
CHECK WASTE TONER	CHECK WASTE TONER PACK
"COLOR ^e " TONER MISINSTALLED	ALIGN TONER CG
FUSER MIS-INSTALLED	ALIGN FU UNIT
CLEANING ROLLER MISINSTALLED	ALIGN FUSER CL ROLLER
BELT CARTRIDGE MISINSTALLED	ALIGN BELT CG
TRANSFER UNIT MISINSTALLED	ALIGN TR ROLLER
OUTPUT BIN JAM	MEDIA JAM

Table 6-2: Normal Mode Messages²

Controller Message	MCTL Message ^a
FRONT DOOR OPEN	CLOSE PANEL FRONT
TOP DOOR OPEN	CLOSE PANEL TOP
REAR DOOR OPEN	CLOSE PANEL REAR
OPTIONAL BIN REAR DOOR OPEN	CLOSE PANEL LFU
DUPLEX UNIT PANEL OPEN	CLOSE PANEL DUP
ENERGY SAVER	SLEEP MODE
CALL FOR SERVICE “ERROR CODE ^f ”	SERVICE CALL

- a. Message on LCD when an error condition occurs while in Service Mode.
- b. “X” refers to media type (for example, transparency, thick stock, etc.); “Y” represents the name of the empty cassette.
- c. “Z” refers to the size of the media (for example, letter, legal, etc.); “Y” represents the name of the empty cassette.
- d. Refers to the color of toner to be replaced.
- e. Refers to the toner cartridge that is misinstalled.
- f. “Error Code” depends on the error. See section 8, “Troubleshooting” for complete list of error codes.

6.2.2 Service Mode

(see Fig. 6-2).

This is the maintenance mode for the service technician only.

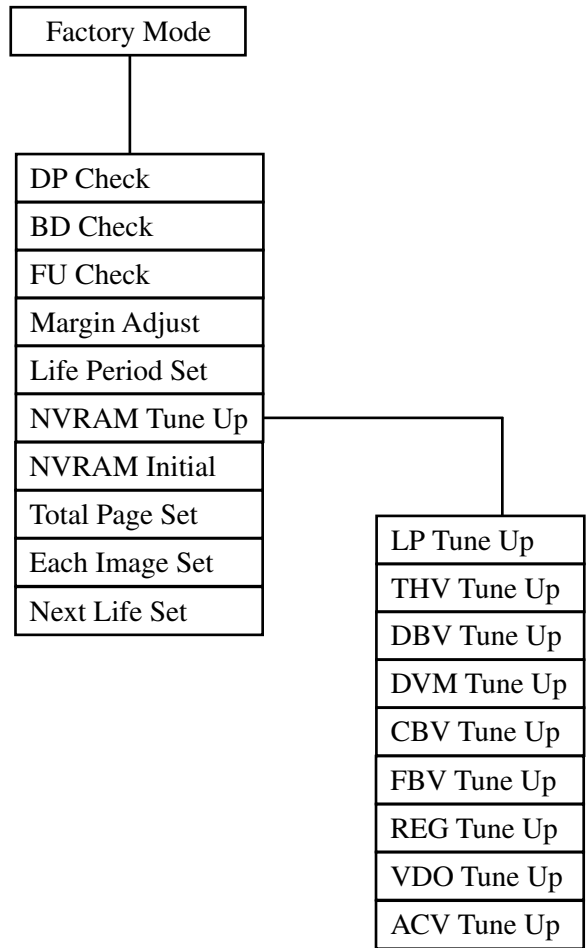

Fig. 6-2

6.3 Operation of Normal Mode

Normal Mode indicates the information which an operator requires for normal maintenance work.

See Table 6-3 for details on the messages in the Normal Mode.

6.3.1 Procedure for Entering Normal Mode Operation

1. Turn on the power to the printer.
2. The ONLINE LED is lit and the READY LED blinks.

6.3.2 Procedure for Normal Mode Operation

Table 6-3: Normal Mode Operations

Message in LCD	Description of Message
IDLE	<ul style="list-style-type: none">• READY LED is lit.• Engine has completed the warming-up process and is ready to print.• Engine is ready to receive a “PRREQ” signal from the controller.
WARMING UP	<ul style="list-style-type: none">• Ready LED blinks.• Engine is in the process of warming up.
INPUT IDLE PRINTING	<ul style="list-style-type: none">• ONLINE LED is on.• Engine is ready to print.
PUT “n” MEDIA IN ANY BIN or PUT “n” MEDIA IN “SELECTED” BIN	<ul style="list-style-type: none">• Engine is in standby mode.• Message LED is on.• Confirm that applicable paper cassette is loaded with the correct media (for example, transparency, thick stock, etc.).• Press Media Key if media is changed.• “n” Represents the type of media (for example, thick stock, paper, etc.) “Selected” represents the paper feed cassette (upper cassette, lower cassette, etc.)
PUT “SIZE” PAPER IN ANY BIN	<ul style="list-style-type: none">• Engine is in standby mode.• Message LED is on.• Refill empty cassette with the appropriate size media.

Table 6-3: Normal Mode Operations

Message in LCD	Description of Message
ADJUST "INPUT BIN"	<ul style="list-style-type: none"> • The specified cassette is missing or not inserted correctly. • Engine is in standby mode. • Message LED is on. • Reinstall the applicable paper cassette into the paper feeder indicated by the LCD.
OUTPUT BIN FULL	<ul style="list-style-type: none"> • The media in the output bin has exceeded its limit (such as over 250 sheets of 20 lb. [75 g/m] bond), • Engine is in standby mode. • Message LED is on. • Remove the paper from the output bin.
"COLOR" TONER LOW	<ul style="list-style-type: none"> • The noted toner is low. There is enough toner left to print approximately 100 pages before the printer stops. • Engine is idle. • Message LED is on. • Replace the indicated toner cartridge with a new toner cartridge. Use OPERATOR CONTROL/ CONSUMABLES/ITEM REPLACED/"COLOR" TONER to clear the message.
"COLOR" TONER EMPTY	<ul style="list-style-type: none"> • The noted toner is empty. • Engine is in standby mode. • Message LED is on. • Replace the indicated toner cartridge with a new toner cartridge. Use "OPERATOR CONTROL/ CONSUMABLES/ITEM REPLACED/"COLOR" TONER to clear the consumable count on the cartridge.
FUSER OIL LOW	<ul style="list-style-type: none"> • The oil bottle for the fuser unit is running low. There is enough oil left to print approximately 100 pages before the printer stops. • Engine is idle. • Message LED is on. • Replace the fuser oil bottle with a new bottle. Use OPERATOR CONTROL/CONSUMABLES/ITEM REPLACED/ FUSER OIL to clear the message.

Table 6-3: Normal Mode Operations

Message in LCD	Description of Message
FUSER OIL EMPTY	<ul style="list-style-type: none"> • The oil bottle for the fuser unit is empty. • Engine is in standby mode. • Message LED is on. • Replace the fuser oil bottle with a new bottle. Use OPERATOR CONTROL/CONSUMABLES/ITEM REPLACED/ FUSER OIL to clear the consumable count on the oil bottle.
CHECK CLEANING ROLLER	<ul style="list-style-type: none"> • Engine is idle. • Message LED is on. • Replace the cleaning roller with a new roller. Use OPERATOR CONTROL/CONSUMABLES/ITEM REPLACED/CLEANING ROLLER to clear the consumable count on the roller.
CHECK WASTE TONER PACK	<ul style="list-style-type: none"> • Either the waste toner pack is full and needs to be replaced, or it is incorrectly installed. • Engine is idle. • Message LED is on. • Replace the waste toner pack with a new one. Use OPERATOR CONTROL/CONSUMABLES/ITEM REPLACED/WASTE TONER PACK to clear the message.
FUSER MIS-INSTALLED	<ul style="list-style-type: none"> • The fuser is not installed, or it is not seated properly. • Engine is in standby mode. • Message LED is on. • Ensure the fuser is installed and/or fully seated. • This message will be automatically cleared after the fuser is properly installed.
CLEANING ROLLER MISINSTALLED	<ul style="list-style-type: none"> • The fuser cleaning roller isn't installed correctly. • Engine is in standby mode. • Message LED is on. • Remove and reinstall cleaning roller. • This message will be automatically cleared after the fuser cleaning roller is properly installed.
"COLOR" TONER MISINSTALLED	<ul style="list-style-type: none"> • The noted toner cartridge is not installed properly. • Engine is in standby mode. • Message LED is on. • Reinstall the toner cartridge correctly. • This message will be automatically cleared after closing the front door.

Table 6-3: Normal Mode Operations

Message in LCD	Description of Message
<p>BELT CARTRIDGE MISINSTALLED</p>	<ul style="list-style-type: none"> • The OPC belt cartridge is either missing or incorrectly installed. • Engine is in standby mode. • Message LED is on. • Ensure that the OPC belt cartridge is correctly installed. • This message will be automatically cleared after closing the front door.
<p>ALIGN TRANSFER ROLLER</p>	<ul style="list-style-type: none"> • The transfer unit is installed incorrectly. • Engine in standby mode and “ALIGN TRANSFER ROLLER” is displayed. • Message LED is on. • Check the transfer unit installation. • This message will be automatically cleared after closing the rear door.
<p>“LOCATION” JAM</p>	<ul style="list-style-type: none"> • The printer has experienced a jam. • Engine is in standby mode. • Message LED is on. • Location of the jam is as follows: DRUM JAM: Drum area. DUPLEX JAM: Duplexer. INNER JAM: OPC belt cartridge area. “INPUTBIN” BIN JAM: Jam in noted cassette. MISFEED JAM: Between the print engine and the input cassette. OUTER JAM: Between the print engine and the output tray. OUTPUT BIN JAM: Between the fuser and output tray rollers located near the top cover. • Locate and remove the jammed media. • Open and close the top door to clear the jam message.
<p>“NOTED” DOOR OPEN</p>	<ul style="list-style-type: none"> • An engine door is open (for example, Top, Front, Rear, or Optional Bin). • Engine halts and “DOOR OPEN” is displayed. • Message LED is on. • Close the indicated door, and the message will be cleared.

Table 6-3: Normal Mode Operations

Message in LCD	Description of Message
ENERGY SAVER	<ul style="list-style-type: none">• The printer is in Energy Saver mode to reduce power consumption during periods of inactivity.• Message LED is on and Ready LED blinks.• This mode is cleared by sending WAKE-UP command from controller.• Printer is ready to print after the warming-up process.
CALL FOR SERVICE “ERROR”	<ul style="list-style-type: none">• An error has been detected with the item indicated in the service message. See section 8, “Troubleshooting,” for full details of errors.• Engine is at standstill.• Message LED is on.

6.4 Service Mode

This Service Mode provides the function to check the operation of the print engine. Operation procedures for all functions are explained below:

6.4.1 Procedures

1. Press and hold the Scroll keys (left and right) and Menu key while you turn on the power.
2. By pressing the Scroll keys, Select key, and Media key, choose the mode necessary for maintenance from the tree shown in Fig. 6-2.

6.4.2 Procedures of Mode Designation

1. By pressing the Scroll keys, you can select one of the Service Modes (see Fig. 6-3).
2. After scrolling to the desired mode, press the Select key for execution.
3. Press the Media key if you want to cancel the present mode.

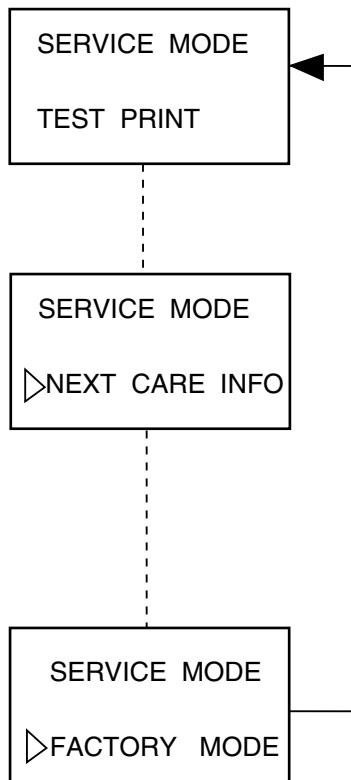

Fig. 6-3

6.4.3 Procedures for Service Mode Operation

6.4.3.1 Test Print

A grid pattern of a single or two colors (R, G, B) and a stripe pattern of full color can be printed with the test print.

Table 6-4: Test Print Procedure

Description of Procedure	Message in LCD
1. Turn off the printer. Holding down both scroll keys (Left and Right) and the MENU Key, turn on the printer.	<pre> graph TD A["A) SERVICE MODE ▷ TEST PRINT / NEXT"] --> B["B) 31 GRID PRT ▷ GRID / STRIPE"] B --> C["C) 31 GRID PRT ▷ Y / M / C / K / R / G / B"] C --> D["D) 31 GRID PRT DUP ▷ 1 / 2 / 3 / SIMP"] D --> E["E) 31 GRID PRT YM"] E --> F["F) MEDIA KEY"] F --> A </pre>
2. Press the SELECT key so that the display changes from screen A) to B).	
3. Select “GRID” with the SCROLL keys. Note that you could select the option of printing a “STRIPE” here.	
4. Press the SELECT key so that the display changes from screen B) to screen C).	
5. Select the color “R” (red) with the SCROLL keys. Note that you could select the option of printing yellow, magenta, cyan, black, red, green, or blue here.	
6. Press the SELECT key so that the display changes from screen C) to screen D). This screen will only appear when the optional duplexer is attached.	
7. Press the SELECT key so that the display changes from screen D) to screen E).	
8. Press the MEDIA key to stop the test print.	
9. Power up the printer to bring it back to normal printing mode.	

6.4.3.2 Next Care Information

Information about the replacement of maintenance parts can be obtained here, including the number of pages printed.

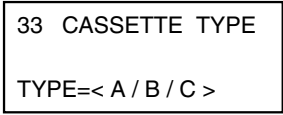

Table 6-5: Next Care Procedure

Step	Description of Procedure	Message in LCD
1	At "NEXTCARE INFO," press the Select Key. The LCD changes as shown in (a) ---> (b)	<p>(a)</p> <div style="border: 1px solid black; padding: 5px; width: fit-content; margin: 5px auto;"> SERVICE MODE ▷ NEXT CARE INFO </div>
2	<p>Using the Scroll key, select the desired information. The LCD changes as shown in (b)</p> <p>Codes for Next Care are as follows: 2: Fuser Cleaning Roller (FC) 7: Belt Cartridge (BL) 8: Fuser Unit (FU) 9: Transfer Drum (TD) 10: Replacement Kit every 240K (OW)</p>	<p>(b)</p> <div style="border: 1px solid black; padding: 5px; width: fit-content; margin: 5px auto;"> 32 NEXT CARE No.=<▲,2,3,4,5,6,7,8,9> </div> <p>(c)</p> <div style="border: 1px solid black; padding: 5px; width: fit-content; margin: 5px auto;"> NEXT FC ROLL 018000P </div> <p>(d)</p> <div style="border: 1px solid black; padding: 5px; width: fit-content; margin: 5px auto;"> NEXT BL UNIT 12000P </div>
3	After selecting the desired information code, press the Select key. Then, the number of images or pages corresponding to the selected code is displayed. The LCD changes as shown in (b) ---> (c) through (g)	<p>(e)</p> <div style="border: 1px solid black; padding: 5px; width: fit-content; margin: 5px auto;"> NEXT FU UNIT 100000P </div> <p>(f)</p> <div style="border: 1px solid black; padding: 5px; width: fit-content; margin: 5px auto;"> NEXT TR DRUM 600000P </div>
4	<p>To clear screens (c) through (g) press the Media key several times.</p> <p>Press the Media key again at screen (b) to return to the Service Mode. The LCD changes as shown in (b) ---> (a)</p>	<p>(g)</p> <div style="border: 1px solid black; padding: 5px; width: fit-content; margin: 5px auto;"> NEXT 240K KIT 240000P </div>

6.4.3.3 Cassette Type



Desired paper feeding cassette can be selected.

Table 6-6: Cassette Type Procedure

Step	Description of Procedure	Message in LCD
1	Press the Select key after selecting Screen (a) "CASSETTE TYPE." The LCD changes as shown in (a) ---> (b)	(a) 
2	Using the Scroll key, select the applicable code for the desired cassette (A: US; B: Europe; or C: Japan), and then press the Select key.	(b) 
3	Press the Clear key to clear the screen (b). The LCD changes as shown in (b) ---> (c)	(c) 

6.4.3.4 Total Page
Total page count.

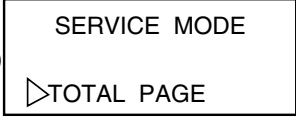
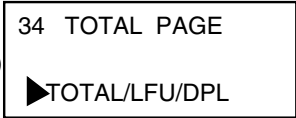
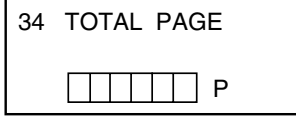
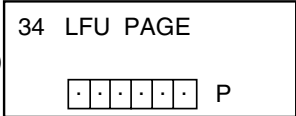
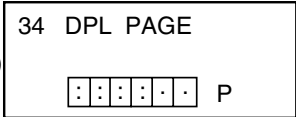
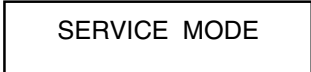

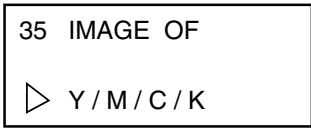
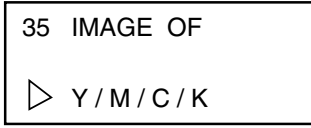

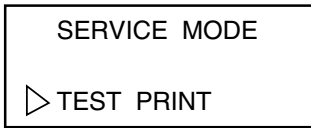

Table 6-7: Total Page Procedures

Step	Description of Procedure	Message in LCD
1	Press Select key after selecting TOTAL PAGE mode. LCD changes as shown in (a) ----> (b)	(a) 
2	Select the type of page from among TOTAL PAGE, LFU PAGE, and DPL PAGE (b)----->(c/d/e).	(b)  (c) 
3	A six digit number is displayed (c). This number represents the total number of pages that have been printed. The LCD changes as shown in (c).	(d)  (e) 
4	Press the Media key to clear the screen (c). The total page count can also be changed for the LFU (d) and the Duplexer (e) ---> (f)	(f) 

6.4.3.5 Each Image

Number of images, per color, can be confirmed.

Table 6-8: Each Image Procedure

Step	Description of Procedure	Message in LCD
1	Press the Select key after selecting EACH IMAGE mode. The LCD changes as shown in (a) ---> (b)	(a) 
2	Using the Scroll key, select the color, and then press the Select key. The LCD changes as shown in (b) ---> (c)	(b) 
3	The number of images per selected color is displayed. The LCD changes as shown in (c)	(c) 
4	Press the Media key to clear the screen (c). The LCD changes as shown in (c) ---> (d)	(d) 
5	Using the Scroll key, select another color, and then use the select key to confirm the number of images per color.	
6	Press the Media key to return to the Service mode. The LCD changes as shown in (d) ---> (e)	(e) 
		

6.4.3.6 Clear Care

The Care Code message displayed in the LCD can be cleared. Make sure to replace the item displayed in the CLEAR CARE menu before using this menu.

Table 6-9: Clear Care Procedure

Step	Description of Procedure	Message in LCD
1	<p>Press the Select key after selecting CLEAR CARE mode. The LCD changes as shown in (a) ---> (b)</p> <p>Codes for Clear Care are as follows: 2: Fuser Cleaning Roller (FC) 7: Belt Cartridge (BL) 8: Fuser Unit (FU) 9: Transfer Drum (TD) 10: Replacement Kit every 240K (OW)</p>	<p>(a) SERVICE MODE ▷ CLEAR CARE</p> <p>(b) 36 CLEAR CARE No.=< FC, BL, FU, OW></p> <p>(c) CARED FC ROLL ? ▷ YES/NO</p>
2	<p>Using Scroll key, select the applicable CARE code, and then press Select key. The LCD changes as shown in (b) ---> (c)</p>	<p>(d) CARED BL UNIT ? ▷ YES/NO</p> <p>(e) CARED FU UNIT ? ▷ YES/NO</p>
3	<p>Use the Scroll key to select YES, and then press the Select key (c)----->(g).</p>	<p>(f) CARED TR DRUM ? ▷ YES/NO</p> <p>(g) CARED 240K KIT ? ▷ YES/NO</p>
4	<p>Press the Media key to clear the CLEAR CARE mode. The LCD changes as shown in (h) ---> (i)</p>	<p>(h) 36 CLEAR CARE No.=< FC, BL, FU, OW></p> <p>(i) SERVICE MODE ▷ TEST PRINT</p>

6.4.3.7 Media Manage

The signal from the OHP sensor can be ignored at the media select (OHP). However, this mode should not be used under normal circumstances.

Table 6-10: Media Manage Procedure

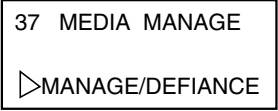
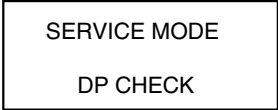
Step	Description of Procedure	Message in LCD
1	Select MEDIA MANAGE and the LCD will change as shown in (a) ---> (b)	(a)  (b) 
2	Select DEFIANCE, and then press the Select key if the OHP sensor signal should be ignored. The LCD changes as shown in (b) ---> (c) In the normal operation, the mode is preset to MANAGE.	(c) 

6.4.3.8 Factory Mode

This mode consists of ten modes for the confirmation of operations and resetting functions necessary for maintenance.

Table 6-11: Factory Mode Menu

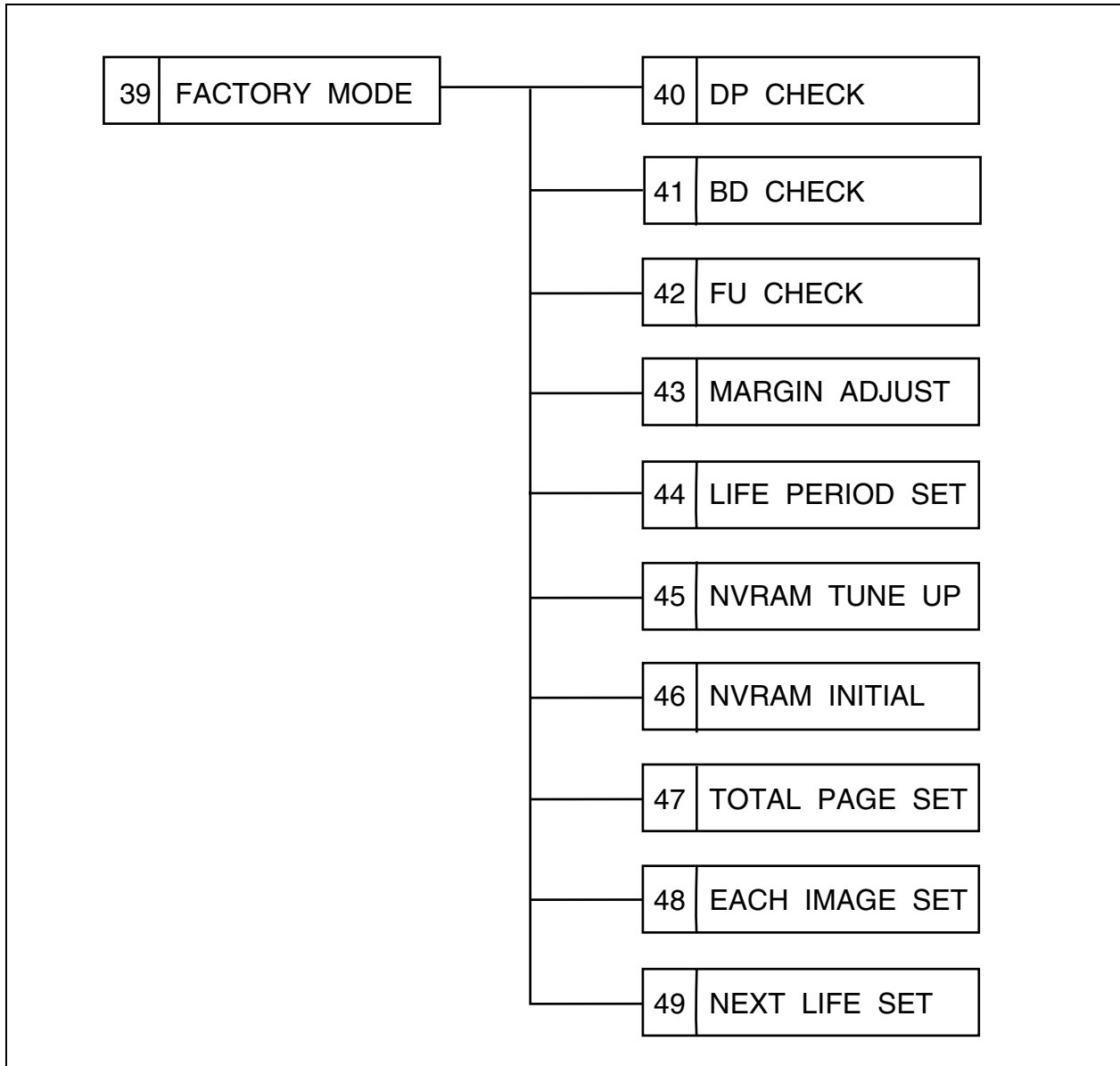

6.4.3.8.1 DP Check

The drive of each toner cartridge can be checked.

Table 6-12: DP Check Procedure

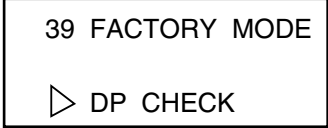
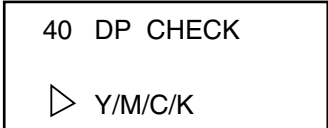
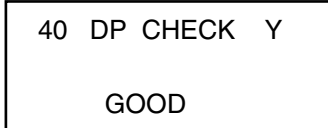
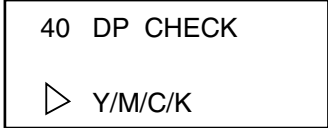
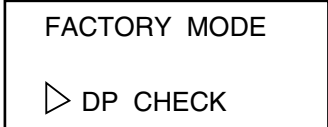
Step	Description of Procedure	Message in LCD
1	Select the DP CHECK. The LCD changes as shown in (a) ---> (b)	(a) 
2	Using the Scroll key, select the desired color, and press Select key. The LCD changes as shown in (b) ---> (c)	(b) 
3	When the yellow toner cartridge is driven and no error is observed by the toner sensor, "GOOD" will be displayed on the panel, otherwise, "FAIL". The LCD changes as shown in (c). Operation of the toner cartridge will be halted automatically after 60 seconds. The LCD changes as shown in (c) ---> (d)	(c)  (d) 
4	Press the Media key to stop the DP CHECK mode. The LCD changes as shown in (d) Press the Media key one more time to return to the status of screen (a). The LCD changes as shown in (d) ---> (e)	(e) 

6.4.3.8.2 BD Check

The laser beam position and laser power can be confirmed.

Table 6-13: BD Check Procedures

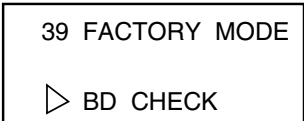
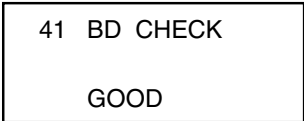
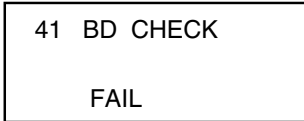
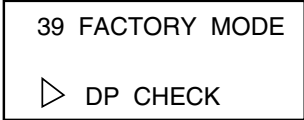
Step	Description of Procedure	Message in LCD
1	<p>Select BD CHECK. The LCD changes as shown in (a) ---> (b)</p>	<p>(a) </p>
2	<p>The Scanner motor scans the laser beam as it is rotating. If the scanning position of the laser beam is normal, "GOOD" is displayed in the LCD, otherwise, "FAIL" is displayed. The LCD changes as shown in (b) or (c)</p> <p>Scanner motor automatically halts to rotate 60 seconds after initial rotation. The LCD changes as shown in (d)</p>	<p>(b) </p> <p>(c) </p>
3	<p>Press the Media key to stop the BD CHECK mode. The LCD changes as shown in (b) ---> (d)</p>	<p>(d) </p>

6.4.3.8.3 FU Check

Availability of oil in the fuser unit can be confirmed.

Table 6-14: FU Check Procedure

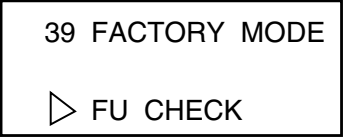
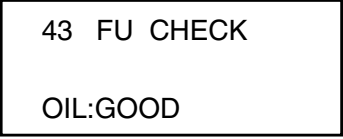
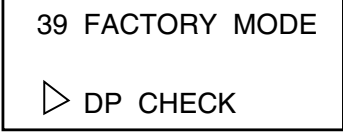
Step	Description of Procedure	Message in LCD
1	Select FU CHECK. The LCD changes as shown in (a) ---> (b)	(a) 
2	Once FU CHECK is selected, the fuser unit starts to heat up and checks the availability of fuser oil. If oil is available in the fuser unit, "GOOD" is displayed in the LCD, otherwise, "FAIL" is displayed. The LCD changes as shown in (b)	(b) 
3	Press the Media key to stop the FU CHECK mode. The LCD changes as shown in (b) ---> (c)	(c) 

6.4.3.8.4 Margin Adjust

The positions of the top and left margins can be confirmed and adjusted within the range between ± 3.5 mm maximum.

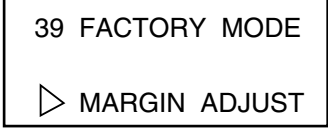
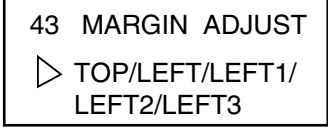
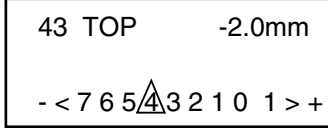
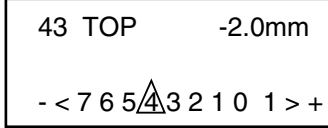
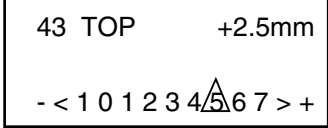
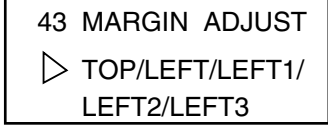
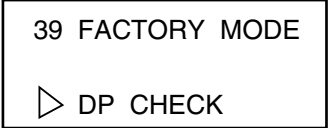

Table 6-15: Margin Adjust Procedure

Step	Description of Procedure	Message in LCD
1	Select MARGIN ADJUST. The LCD changes as shown in (a) ---> (b)	
2	Using the Scroll key, select either TOP or LEFT1/ LEFT2/LEFT3, and then, press Select key. The LCD changes as shown in (b) ---> (c) TOP : For adjustment of the left edge of the upper cassette. LEFT1 : For adjustment of the left edge of the lower cassette (1). LEFT2 : For adjustment of the left edge of the lower cassette (2). LEFT3 : For adjustment of the left edge from the duplex unit.	(a)  (b)  (c) 
3	Margins can be adjusted by 3.5 mm maximum at both ends (left and right) incremental by 0.5 mm. Using the Scroll key, select the amount of adjustment by selecting a number displayed in screen (c) or (d). In this instance, the amount of adjustment selected will be displayed at the upper-right corner of screen (c) or (d). After confirming the desired amount of adjustment is displayed, press Select key to set the adjustment.	(c)  (d)  (e) 
4	Press the Media key to terminate MARGIN ADJUST mode. The LCD changes as shown in (d) ---> (e) Press the Media key again to return to FACTORY MODE. The LCD changes as shown in (e) ---> (f)	(f) 

6.4.3.8.5 Life Period Set

Note: These are factory settings and should not be changed.
The replacement life of the periodical replacement parts can be set.

Table 6-16: Life Period Set Procedure

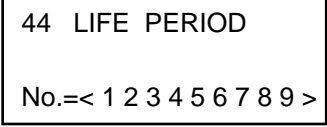
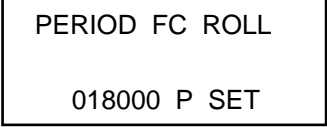
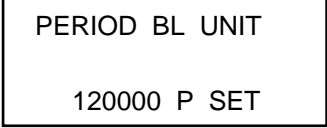
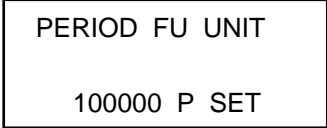
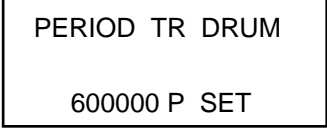
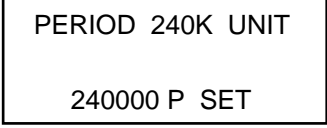
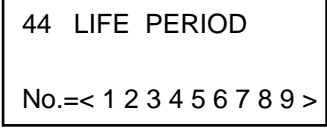
Step	Description of Procedure	Message in LCD
1	<p>Select LIFE PERIOD mode.</p> <p>The LCD changes as shown in (a) ---> (b)</p>	<p>(a)  </p>
2	<p>Using the Scroll key, select the desired code and then press the Select key.</p> <p>2: Fuser Cleaning Roller [see (b) ---> (c)] 7: Belt Cartridge [see (d)] 8: Fuser Unit [see (e)] 9: Transfer Drum [see (f)] 10: 240K Replacement Kit [see (g)]</p>	<p>(b) </p> <p>(c) </p>
3	<p>Use the Scroll key to designate or change the desired digit.</p> <p>Use the Select key to input values to the blinking digit.</p> <p>After the new values are defined, use the scroll key to move the cursor to SET displayed in the LCD, and then, press the Select key to register the set value.</p>	<p>(d) </p> <p>(e) </p> <p>(f) </p>
4	<p>Press the Media key to complete the setting work.</p> <p>The LCD changes as shown in (g)</p> <p>Press the Media key one more time to return to FACTORY MODE.</p> <p>The LCD changes as shown in (g) ---> (h)</p>	<p>(g) </p> <p>(h) </p>

6.4.3.8.6 NVRAM Tune Up

Note: These are factory settings and should not be changed.

This mode is not used in normal operation, but is used when fine adjustments of values are required. This mode consists of following nine modes:

Table 6-17: NVRAM Tune Up Menu

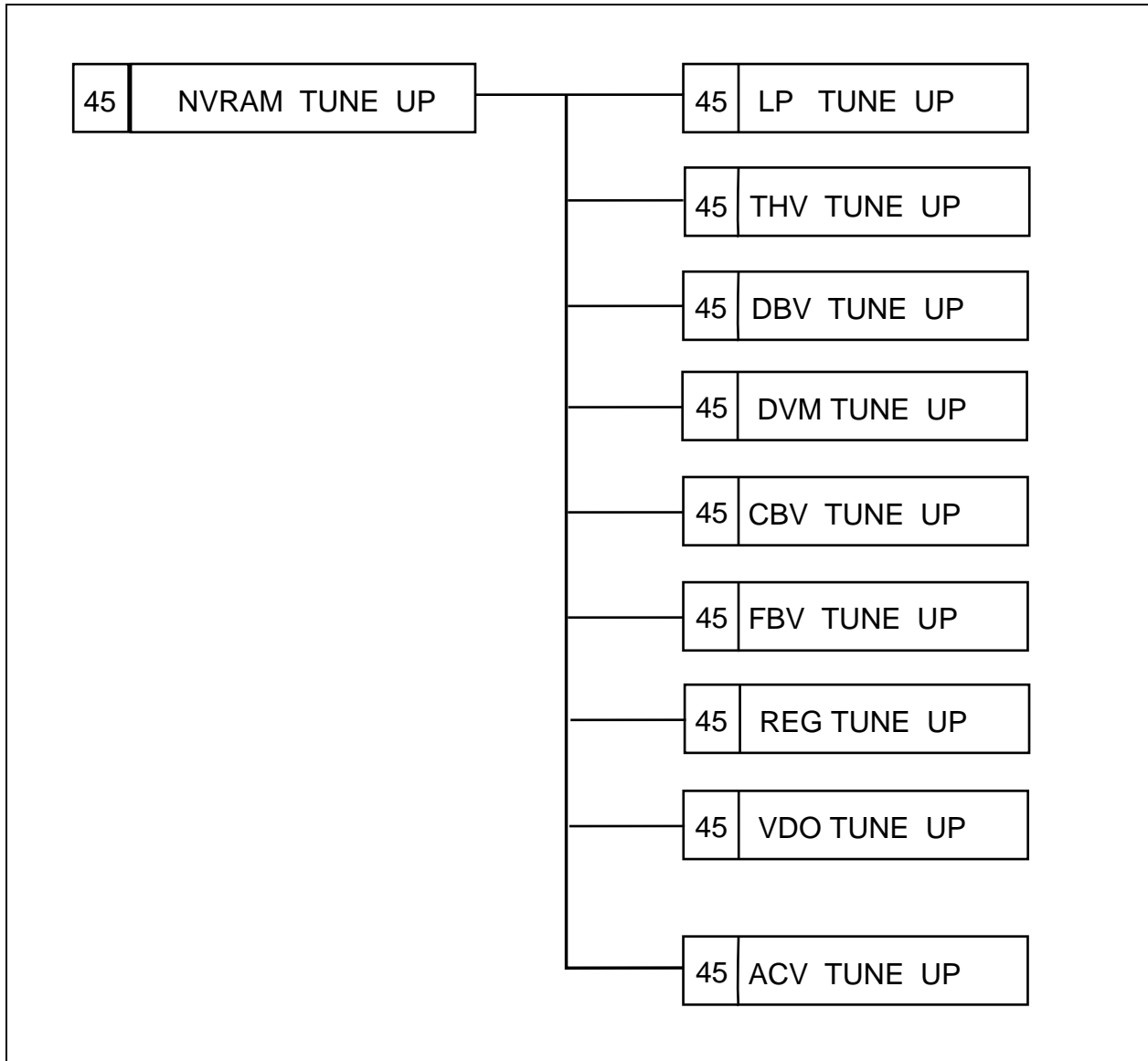

6.4.3.8.6.1 LP Tune Up

Note: These are factory settings and should not be changed.

This mode should be used when optical density, line thickness and/or color reproduction need to be adjusted. The adjustment will be made by changing the laser power against a reference value 0 (zero) between a range of -4 and +4.

Table 6-18: LP Tune Up Procedure

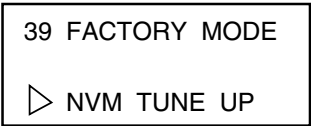
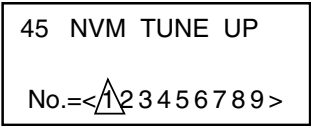
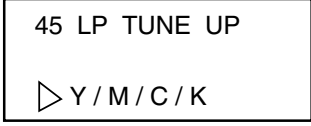
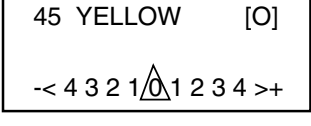
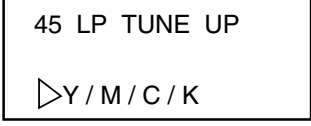
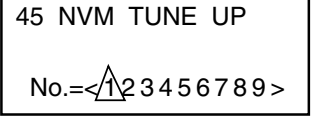
Step	Description of Procedure	Message in LCD
1	Select NVM TUNE UP. The LCD changes as shown in (a) ---> (b)	(a) 
2	After selecting LP TUNE UP Code 1, press the Select key. The LCD changes as shown in (b) ---> (c)	(b) 
3	After selecting the color to be altered, press the Select key. The LCD changes as shown in (c) ---> (d)	(c) 
4	Tune Up value can be adjusted by 8 increments between -4 and +4. After selecting a given number, press the Select key. The LCD changes as shown in (d)	(d) 
5	Press the Media key to end this procedure for the yellow toner. The LCD changes as shown in (d) ---> (e) Repeat steps 3 through 5 whenever adjustment is required for each toner color.	(e) 
6	Press the Media key to complete the tune-up work. The LCD changes as shown in (e) ---> (f)	(f) 

6.4.3.8.6.2 THV Tune Up

Note: These are factory settings and should not be changed.

This mode shall be used when the transfer voltage needs to be adjusted due to the errors such as transfer failure on the media. The adjustment changes the transfer voltage, subject to the media to be used, against a reference value 0 (zero) between a range of -4 and +4.

Table 6-19: THV Tune Up Procedure

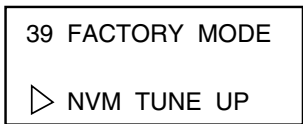
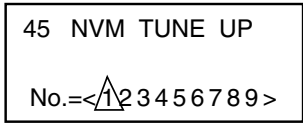
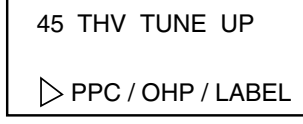
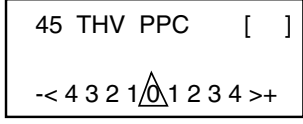
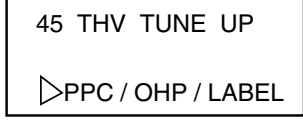
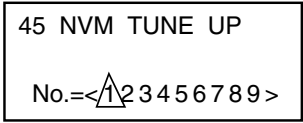
Step	Description of Procedure	Message in LCD
1	Select THV TUNE UP. The LCD changes as shown in (a) ---> (b)	(a) 
2	After selecting THV TUNE UP Code 2, press Select key. The LCD changes as shown in (b) ---> (c)	(b) 
3	After selecting the media to be corrected, press Select key. (Ex. PPC) The LCD changes as shown in (c) ---> (d)	(c) 
4	Tune Up value can be adjusted within 8 increments between -4 and +4. After selecting a given number, press Select key. The LCD changes as shown in (d)	(d) 
5	Press the Media key to finish this procedure. The LCD changes as shown in (d) ---> (e) Repeat steps 3 through 5 for other media such as OHP or Label.	(e) 
6	Press the Media key to end this procedure. The LCD changes as shown in (e) ---> (f)	(f) 

6.4.3.8.6.3 DBV Tune Up

Note: These are factory settings and should not be changed.

This mode shall be used when image optical density needs to be adjusted. Adjustment is made to the developer bias voltage against a reference value 0 (zero) between a range of -4 and +4.

Table 6-20: DBV Tune Up Procedure

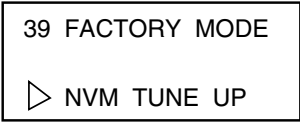
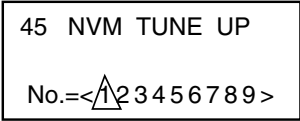
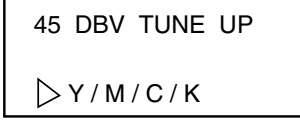
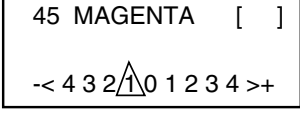
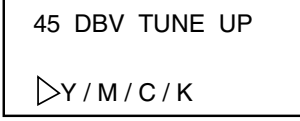
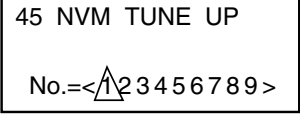
Step	Description of Procedure	Message in LCD
1	Select DBV TUNE UP. The LCD changes as shown in (a) ---> (b)	(a) 
2	After selecting DBV TUNE UP Code 3, press the Select key. The LCD changes as shown in (b) ---> (c)	(b) 
3	After selecting the color to be tuned up, press the Select key The LCD changes as shown in (c) ---> (d)	(c) 
4	Tune Up value can be adjusted in 8 increments between -4 and +4. After selecting a given number, press the Select key. The LCD changes as shown in (d) ---> (e)	(d) 
5	Press the Media key to finish this procedure for Magenta. The LCD changes as shown in (d) ---> (e) Repeat the step 3 through 5 for each color.	(e) 
6	Press the Media key to finish this procedure. The LCD changes as shown in (e) ---> (f)	(f) 

6.4.3.8.6.4 CBV Tune Up

Note: These are factory settings and should not be changed.

This mode is used when the image defects attributing to OPC belt need to be improved. An adjustment is made to the OPC belt bias voltage against a reference value 0 (zero) between a range of -4 and +4.

Table 6-21: CBV Tune Up Procedure

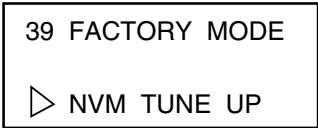
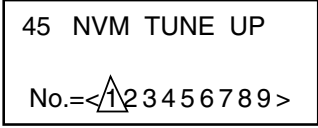
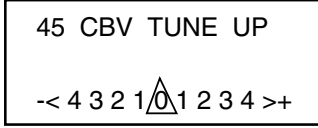
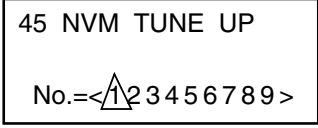
Step	Description of Procedure	Message in LCD
1	Select CBV TUNE UP The LCD changes as shown in (a) ---> (b)	(a) 
2	After selecting CBV TUNE UP Code 5, press the Select key. The LCD changes as shown in (b) ---> (c)	(b) 
3	Tune Up value can be adjusted by 9 increments between -4 and +4. After selecting a given number, press the Select key. The LCD changes as shown in (c)	(c) 
4	Press the Media key to complete this procedure. The LCD changes as shown in (c) ---> (d)	(d) 

6.4.3.8.6.5 FBV Tune Up

Note: These are factory settings and should not be changed.

This mode should be used when image defects attributed to the transfer drum need to be corrected. An adjustment is made to the drum cleaner bias voltage against a reference value 0 (zero) between a range of -4 and +4.

Table 6-22: FBV Tune Up Procedure

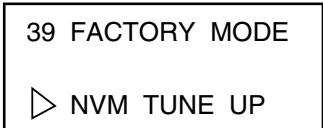
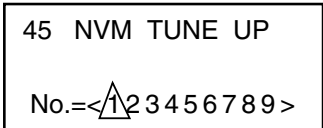
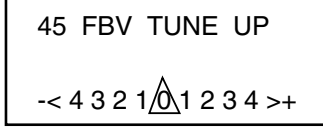
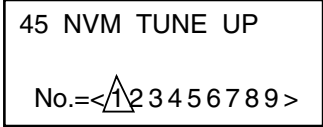
Step	Description of Procedure	Message in LCD
1	Select FBV TUNE UP. The LCD changes as shown in (a) ---> (b)	(a) 
2	After selecting FBV TUNE UP Code 6, press the Select key. The LCD changes as shown in (b) ---> (c)	(b) 
3	Tune Up value can be adjusted within 8 steps between the step -4 and +4. After selecting a given number, press the Select key. The LCD changes as shown in (c)	(c) 
4	Press the Media key to wrap up the tune-up work for FBV. The LCD changes as shown in (c) ---> (d)	(d) 

6.4.3.8.6.6 ACV Tune Up

Note: These are factory settings and should not be changed.

This mode shall be used to improve an insufficient separation of the paper from the transfer drum (when a winding jam has occurred around the drum). By using this mode, you can adjust the bias voltage of the paper discharging output from the high voltage power supply unit (HVU). This adjustment is made between a range of -4 and +4.

Table 6-23: ACV Tune Up Procedure

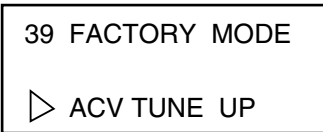
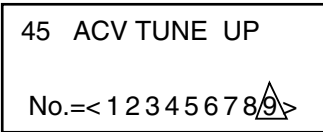
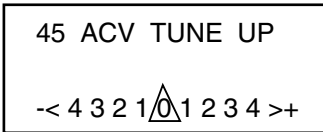
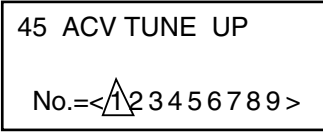
Step	Description of Procedure	Message in LCD
1	Select ACV TUNE UP. The LCD changes as shown in (a) ---> (b)	(a) 
2	After selecting ACV TUNE UP Code 9, press the Select key. The LCD changes as shown in (b) ---> (c)	(b) 
3	Tune Up value can be adjusted within 9 steps between the step -4 and +4. After selecting a given number, press the Select key. The LCD changes as shown in (c)	(c) 
4	Press the Media key to complete this procedure. The LCD changes as shown in (c) ---> (d)	(d) 

6.4.3.8.6.7 NVRAM Initialization

Note: These are factory settings and should not be changed.

This mode can clear all the data of NVRAM on MCTL PWB, and can also execute NVRAM CLEAR to clear C3 error when it occurs.

WARNING

NVRAM INITIAL is not used under normal circumstances! Execution of this mode will result in the loss of all the data in NVRAM. Therefore, all the data in NVRAM should be recorded prior to executing NVRAM INITIAL.

Table 6-24: NVRAM Initialization Procedure

Step	Description of Procedure	Message in LCD
1	Select NVRAM INITIAL. The LCD changes as shown in (a) ---> (b)	
2	Select YES if NVRAM should be executed. If not, select NO. Press the Select key so that NVRAM INITIAL will be executed. (All the data will be cleared.) The LCD changes as shown in (b) ---> (c)	(a) <div style="border: 1px solid black; padding: 5px; display: inline-block;">39 FACTORY MODE ▷ NVRAM INITIAL</div>
3	The following modes shall be executed to set the RAM data. 43 MARGIN ADJUST 44 LIFE PERIOD SET 45 NVRAM TUNE UP 47 TOTAL PAGE SET 48 EACH IMAGE SET 49 NEXT LIFE SET When setting NVRAM TUNE UP, LP TUNE UP should be set at "+4".	(b) <div style="border: 1px solid black; padding: 5px; display: inline-block;">46 NVRAM INITIAL ▷ YES / NO</div> (c) <div style="border: 1px solid black; padding: 5px; display: inline-block;">39 FACTORY MODE ▷ DP CHECK</div>

6.4.3.8.6.8 Total Page Reset

Note: These are factory settings and should not be changed.

This mode can reset the number of total pages in NVRAM whenever executing NVRAM INITIAL or replacing the MCTL PWB.

Table 6-25: Total Page Reset Procedure

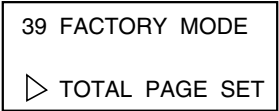
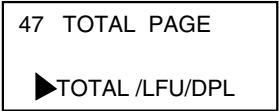
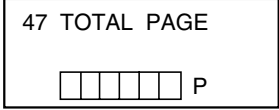
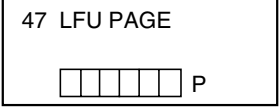
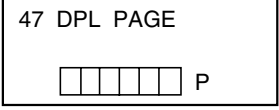
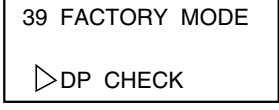
Step	Description of Procedure	Message in LCD
1	<p>Select TOTAL PAGE SET.</p> <p>The LCD changes as shown in (a) ---> (b)</p>	<p>(a) </p> <p>(b) </p>
2	<p>Select the type of page (for example, TOTAL PAGE, LFU PAGE, or DPL PAGE).</p> <p>The LCD changes as shown in (b) ---> (c)</p>	<p>(c) </p> <p>or</p> <p>(c) </p>
3	<p>Use the Scroll key to designate or change the desired digits. Use the Select key to select a digit.</p> <p>After selecting the values to be set, use the scroll key to move the cursor to SET displayed in the LCD, and then press the Select key to select the value.</p> <p>The LCD changes as shown in (c) ---> (d)</p>	<p>(c) </p> <p>or</p> <p>(d) </p>

6.4.3.8.6.9 Each Image Reset

Note: These are factory settings and should not be changed.

This mode resets the number of total planes/ images printed for each color in NVRAM when executing NVRAM INITIAL or replacing the MCTL PWB.

Table 6-26: Each Image Reset Procedure

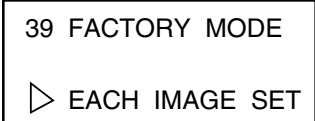
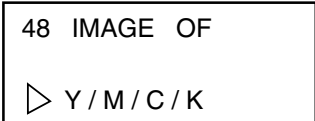
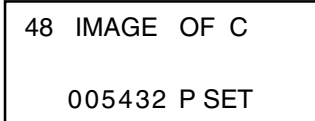
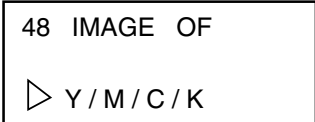
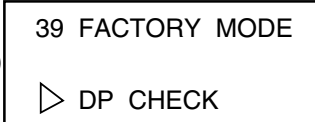
Step	Description of Procedure	Message in LCD
1	<p>Select EACH IMAGE SET.</p> <p>The LCD changes as shown in (a) ---> (b)</p>	<p>(a) </p>
2	<p>Select the desired color for EACH IMAGE SET.</p> <p>The LCD changes as shown in (b) ---> (c)</p>	<p>(b) </p>
3	<p>Use the Scroll key to designate or change the desired digits.</p> <p>Use the Select key to select a digit.</p> <p>After selecting the values to be set, use the Scroll key to move the cursor to SET, and then press the Select key to select the value.</p> <p>The LCD changes as shown in (c) ---> (d)</p>	<p>(c) </p> <p>(d) </p>
4	<p>Press the Media key to exit from the EACH IMAGE SET mode.</p> <p>The LCD changes as shown in (d) ---> (e)</p>	<p>(e) </p>

6.4.3.8.6.10 Next Life Set

Note: These are factory settings and should not be changed.

This mode sets the replacement timing (number of prints) for the periodic replacement of maintenance parts.

Table 6-27: Next Life Set Procedure

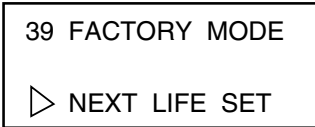
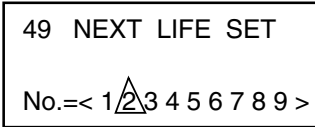
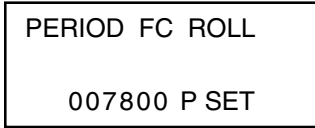
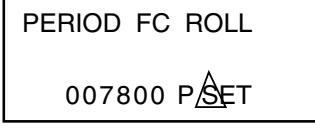
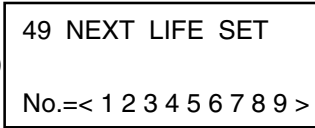
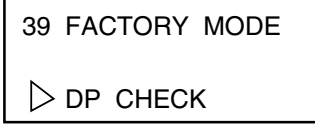
Step	Description of Procedure	Message in LCD
1	Select NEXT LIFE SET.	
2	<p>After selecting the code to be set, press the Select key (for example, Fuser Cleaning Roller).</p> <p>2: Fuser Cleaning Roller LCD changes as shown in (a) ---> (b)</p> <p>7: Belt Cartridge 8: Fuser Unit 9: Transfer Drum 10: 240K Volume Stack Kit</p>	<p>(a) </p> <p>(b) </p>
3	<p>Designate or change the value with Scroll key.</p> <p>The LCD changes as shown in (b) ---> (c)</p> <p>Use the Select key to input the number to the blinking value (for example, 7800).</p> <p>After inputting the desired number (for example, 7800), move the cursor to SET with the Scroll key. Then, press the Select key to complete the registration of desired number (for example, 7800).</p> <p>The LCD changes as shown in (c) ---> (d)(e)</p>	<p>(c) </p> <p>(d) </p> <p>(e) </p>
4	<p>Press the Media key to complete the procedure of NEXT LIFE SET.</p> <p>The LCD changes as shown in (e) ---> (f)</p>	<p>(f) </p>

6.5 Adjustment Procedures

6.5.1 Adjustment of Top and Left Margins

The top and left margins can be adjusted at the operator panel.

6.5.1.1 Purpose

If there is no top margin or left margin for the imageable area or when MCTL PWB is replaced, the adjustment of top and left margins is required.

6.5.1.2 Adjustment Procedure

1. Execute “GRID PRINT” in the SERVICE MODE.
2. Measure the position ‘A’ and ‘B’ of leading edge top margin.
(A + B) / 2 Default Value $\delta 4.0 \pm 1.5\text{mm}$
3. Measure the position ‘C’ and ‘D’ of left margin.
(C + D) / 2 Default Value $\delta 3.0 \pm 1.5\text{mm}$
4. If the specification value is not met, implement the following adjustment. Execute “43 MARGIN ADJUST” in the FACTORY MODE.
5. After the above adjustment, execute “GRID PRINT” and confirm the margin.

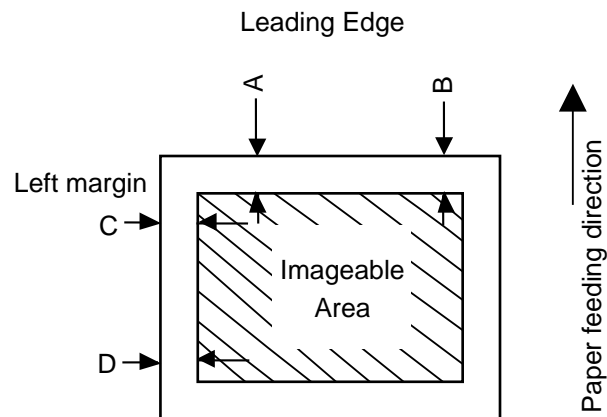

Fig. 6-4

6.5.1.3 Adjustment of Left Margin if Duplexer is Installed

When installing a duplexer, it may be required to adjust the left margin. Confirm and adjust the left margin according to the following procedure:

6.5.1.3.1 Purpose

To print within the guaranteed print area of paper.

6.5.1.3.2 Timing

At addition of the option, At the replacement of MCTL PWB.

6.5.1.3.3 Specification value of the adjustment

$l=3.0\pm 1.5\text{mm}$.

6.5.1.3.4 Procedure

1. Measure the left margin position C and D of paper.
2. Confirm if measurements meet the specification value.
 $(C+D)/2 < \text{Default Value } \delta 3.0 \pm 1.5\text{mm}$.
3. If measurements do not meet the specification value, implement the Adjustment Method described in section 6.5.1.4.

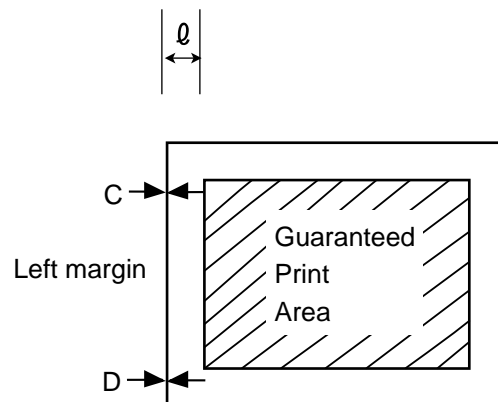

Fig. 6-5

6.5.1.4 Adjustment Method

There are two adjustment methods (see Table 6-28).

1. Make the adjustment in Normal Mode. See the Operation Manual for complete instructions.
2. Make the adjustment in Service Mode (for authorized service personnel only). This manual explains about the “adjustment from the operator panel” as follows:

Table 6-28: Left Margin Adjustment Methods

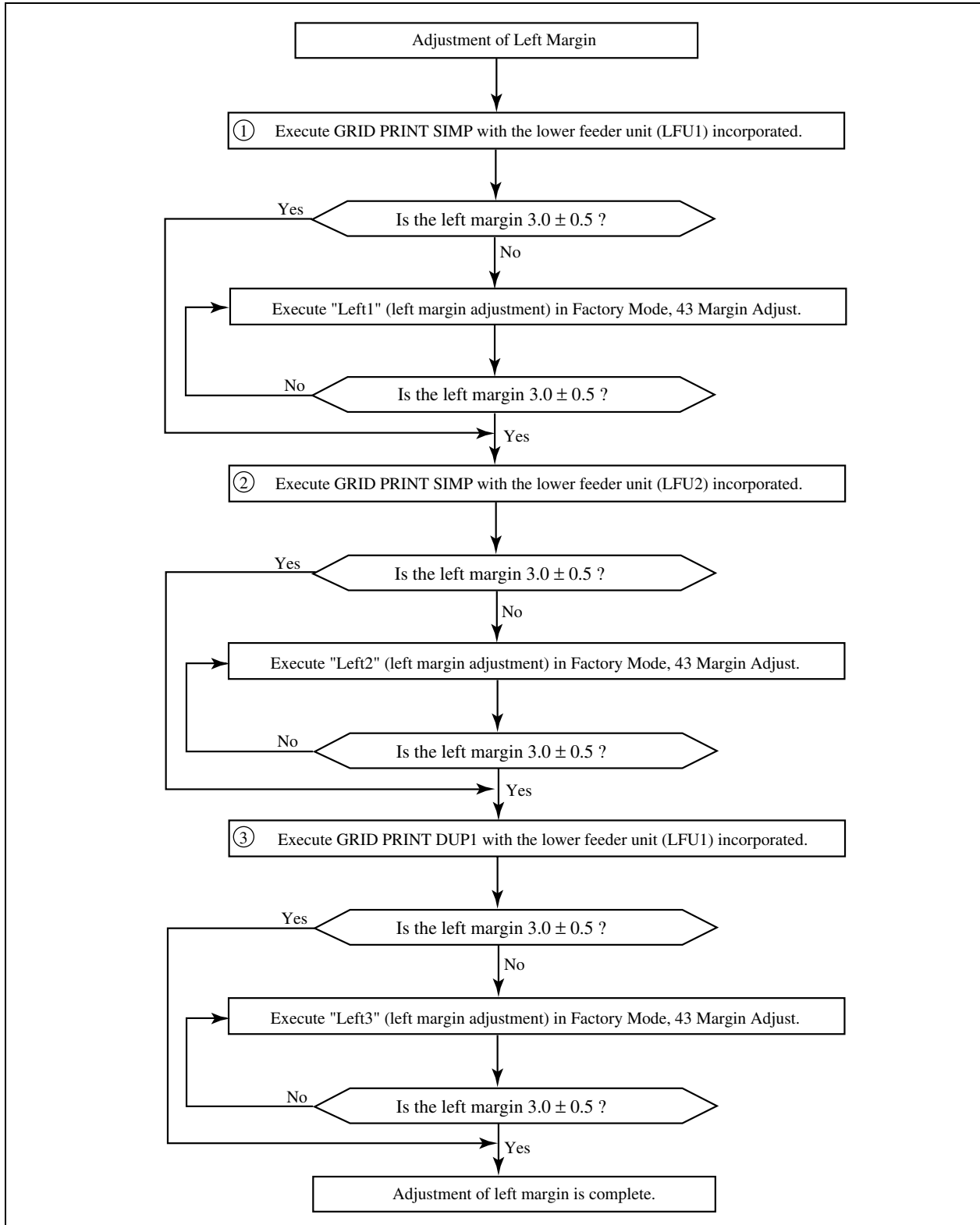

6.5.2 Setting of RAM Data

As Data in RAM has been preset to the optimum value at the factory, it is not necessary to change the preset value under normal conditions. However, fine adjustment may be required subject to media or operational conditions.

6.5.2.1 Purpose:

Print quality can be improved by changing the preset value in RAM.

6.5.2.2 Procedures:

1. Follow the procedures set out in 6.4 Service Mode.
2. Select RAM TUNE UP mode.
3. Select the desired TUNE UP mode.
4. Adjust the preset value to the appropriate value (step).
5. Implement the test print to confirm the print quality.

6.5.2.3 TUNE UP Modes

Table 6-29: Tune Up Modes

Mode	Adjustment	Purpose
LP TUNE UP	Adjustment of laser power	Optical density
THV TUNE UP	Adjustment of transfer voltage	Transfer efficiency
DBV TUNE UP	Adjustment of developer bias	Optical density
CBV TUNE UP	Adjustment of OPC belt bias	Development efficiency
FBV TUNE UP	Adjustment of cleaning roller bias	Drum cleaning efficiency
ACV TUNE UP	Adjustment of paper discharging output bias	Drum jam prevention

6.5.3 Confirmation and Setting of the Total Number of Printouts

The total number of printouts is stored in the RAM. Confirmation and setting of the total number of printouts can be checked and reset through the operator panel.

6.5.3.1 Purpose

The total number of printouts will be reset when changing the MCTL PWB or executing the NVRAM INITIAL.

6.5.3.2 Procedure

1. Execute 47 TOTAL PAGE in the Factory Mode.
2. Reset the total number of printouts.
3. Execute 34 TOTAL PAGE to confirm that the desired number of printouts is now set.

6.5.4 Setting of the Number of Images Per Color

The number of printouts of each color (4 colors) is stored in RAM. Confirmation and setting of the total number of printouts can be checked and reset through the operator panel.

6.5.4.1 Purpose

The number of images per color should be reset when changing the MCTL P.W.B. or executing the NVRAM INITIAL.

6.5.4.2 Procedure

1. Execute 48 EACH IMAGE in the Factory Mode.
2. Reset the number of printouts for each color.
3. Execute 35 EACH IMAGE to confirm that the desired number of images is now set.

6.5.5 Initial Setting of RAM

Implement the initial setting after the replacement of MCTL P.W.B. and clearing the contents of RAM.

6.5.5.1 Purpose

Contents of NVRAM must be reset after changing the MCTL P.W.B. or executing the NVRAM INITIAL.

6.5.5.2 Procedure

1. Prior to replacing the MCTL P.W.B., confirm the contents of RAM (see Table 6-30).
2. Execute 46 NVRAM INITIAL in the FACTORY MODE.
3. After implementing the NVRAM INITIAL, input the value confirmed in step 1 above into RAM to complete the setting.

Table 6-30: Factory Mode

Code	Subject	Confirmation Value
43	MARGIN ADJUST	Top Margin Set Value
43	MARGIN ADJUST	Left Margin Set Value
45	LP TUNE UP	Adjustment Value (“+4” normally)
45	THV TUNE UP	Adjustment Value (“0” normally, “-2” for labels)
45	DBV TUNE UP	Adjustment Value (“0” normally)
45	CBV TUNE UP	Adjustment Value (“+1” normally)
45	FBV TUNE UP	Adjustment Value (“0” normally)
45	ACV TUNE UP	Adjustment Value (“0” normally)
47	TOTAL PAGE SET	Total Print Count
47	LFU PAGE SET	Print Count from LFU
47	DPL PAGE SET	Print Count from Duplex
48	EACH IMAGE SET	Formed Image Count of 4 Colors
49	NEXT LIFE SET	Print Count for Maintenance Replacement Parts

Section 7:
Replacement Procedures

7.0 Replacement Procedures

Adhere to the procedures and precautions described below for maintenance.

1. Do not implement any operation, disassembly, and modification etc., which is not set out in this manual.
2. Turn the power supply OFF and unplug the power supply cable from the outlet prior to starting disassembly or check.
3. This printer incorporates the dangerous parts subject to the warnings such as “High Temperature,” “High Voltage”, and “Laser Radiation.” Before starting any work on this printer, read and understand the warnings set out in this manual.
4. Collect and dispose the waste toner or toner. However, strictly refrain from dumping them into a fire.
5. Remove grounding when replacing or removing Low Voltage Power Supply. After completing the replacement work, confirm that the ground wire is put back and connected to the earth ground.
6. Confirm the orientation of parts and length of screws in the replacement of the maintenance parts (see Table 7-1).
7. Do not use any solvent such as alcohol for the maintenance of this printer.
8. Confirm that all the parts and covers are installed or assembled properly prior to starting the test run after replacement of the maintenance parts.
9. When handling any P.W.B. use ESD precautions.

NOTE:

See section 8.0 “Troubleshooting,” and section 9.0, “Spare Parts Break-down,” for reference.

Table 7-1: Table of Applicable Screws

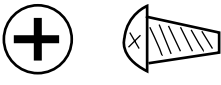
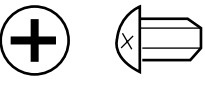
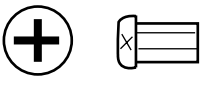
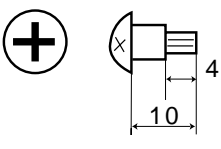
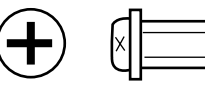
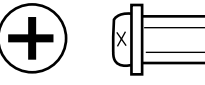
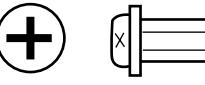
Class Code	Name of Screw	M-Thread TS	Length	Shape	Remarks
BT3 x 8	Cross-recessed head-tapping screw	T3	8 mm		For installation of plastic parts
BT3 x 12		T3	10 mm		
		T4	6 mm		
BT4 x 8		T4	8 mm		
BT4 x 10		T4	10 mm		
ST3 x 6	S tight screw	ST	6 mm		For installation of parts to steel plate
ST4 x 6					
M4 x 6	Cross-recessed head-tapping screw (Pan head)	M4	6 mm		For frame and GND
SP3	Unique screw for heater connector	M3	10 mm		For fuser connector
F3 x 6	Cross-recessed head screw with flange	M3	6 mm		
F4 x 6	Cross-recessed head screw with flange	F4	6 mm		For fuser
FST3 x 10	Cross-recessed head S tight screw with flange	FST	10 mm		For fuser

7.1 Replacement of Covers

Cover Names (see Fig. 7-1 and Fig. 7-2)

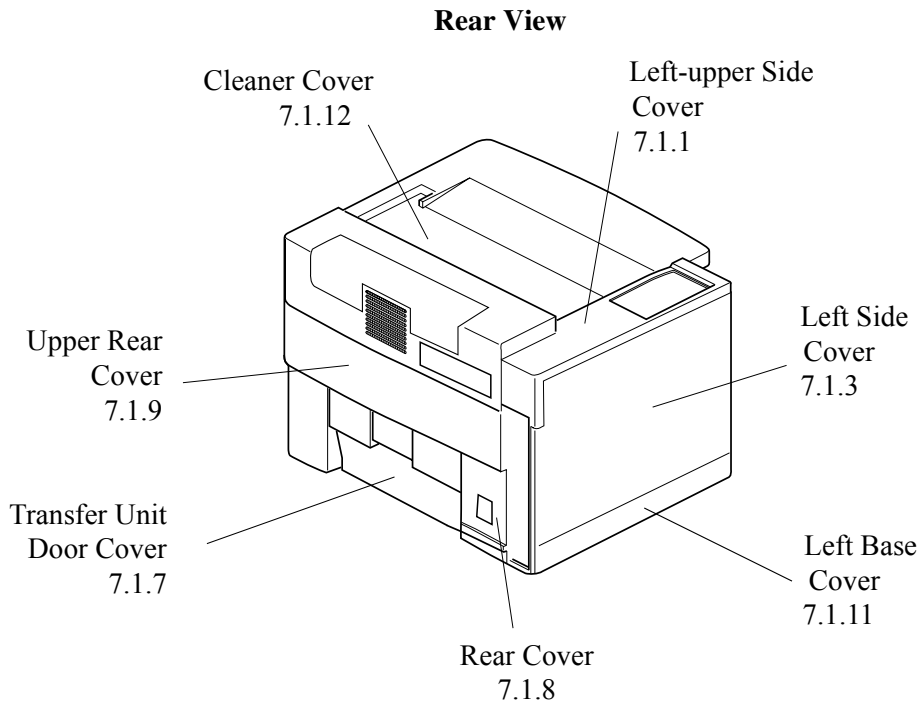
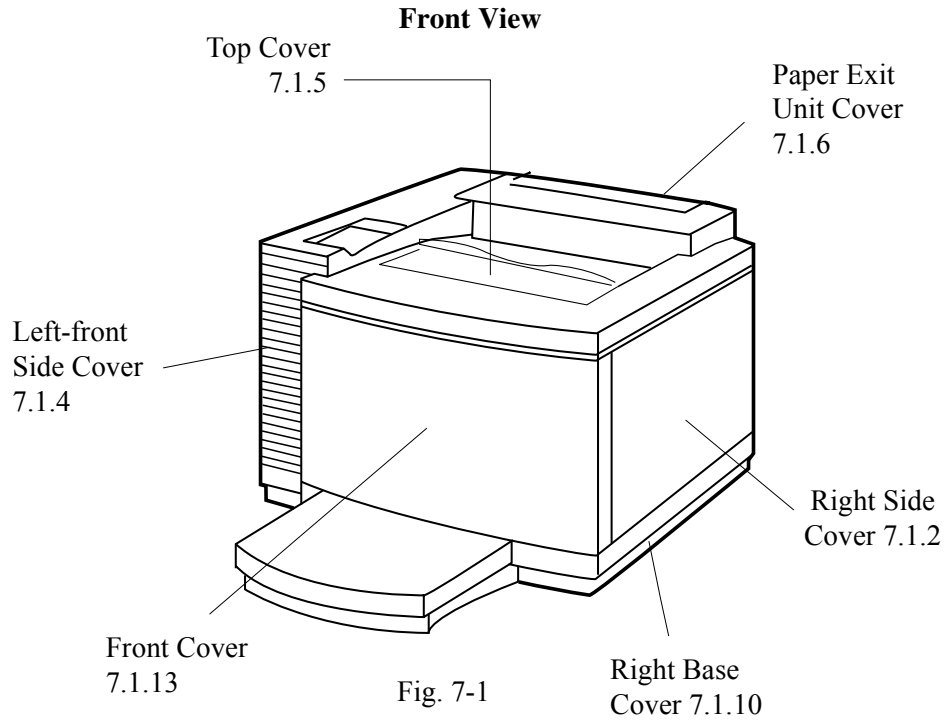

7.1.1 Left-upper Side Cover

7.1.1.1 Tools

#2 Phillips Screwdriver

7.1.1.2 Disassembly Procedures

(see Fig. 7-3 and Fig. 7-4)

1. Open the paper exit unit.
2. Remove one set screw (BT4X10) from left-upper side cover.
3. By pressing the exterior of the left side cover, unlatch the three interlocks from the Left-upper side cover.

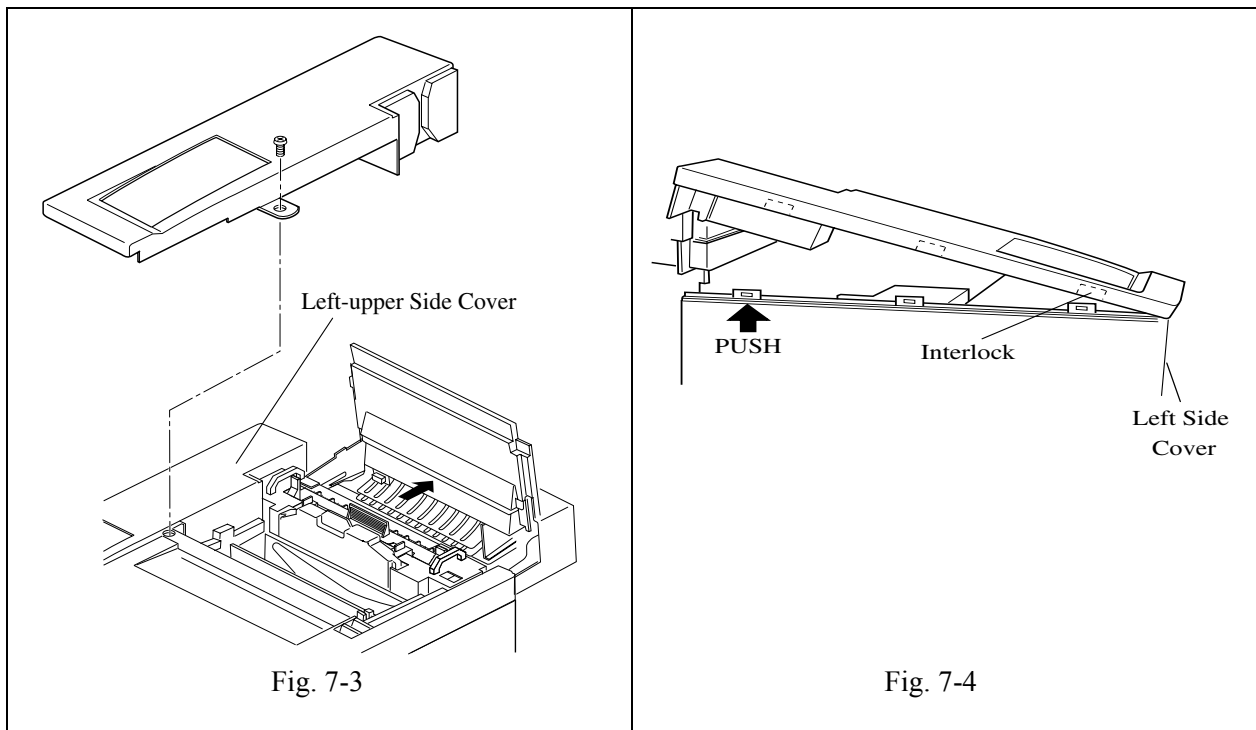

7.1.1.3 Assembly Procedures

1. Assemble the left-upper side cover in reverse order of disassembly.

7.1.2 Right Side Cover

7.1.2.1 Tools

#2 Phillips Screwdriver

7.1.2.2 Disassembly Procedures

1. Open the front door.
2. Remove one set screw (BT4X10) from right side cover (see Fig. 7-5).
3. Slide the right side cover to the arrow direction (see Fig. 7-6).
4. Remove the right side cover.

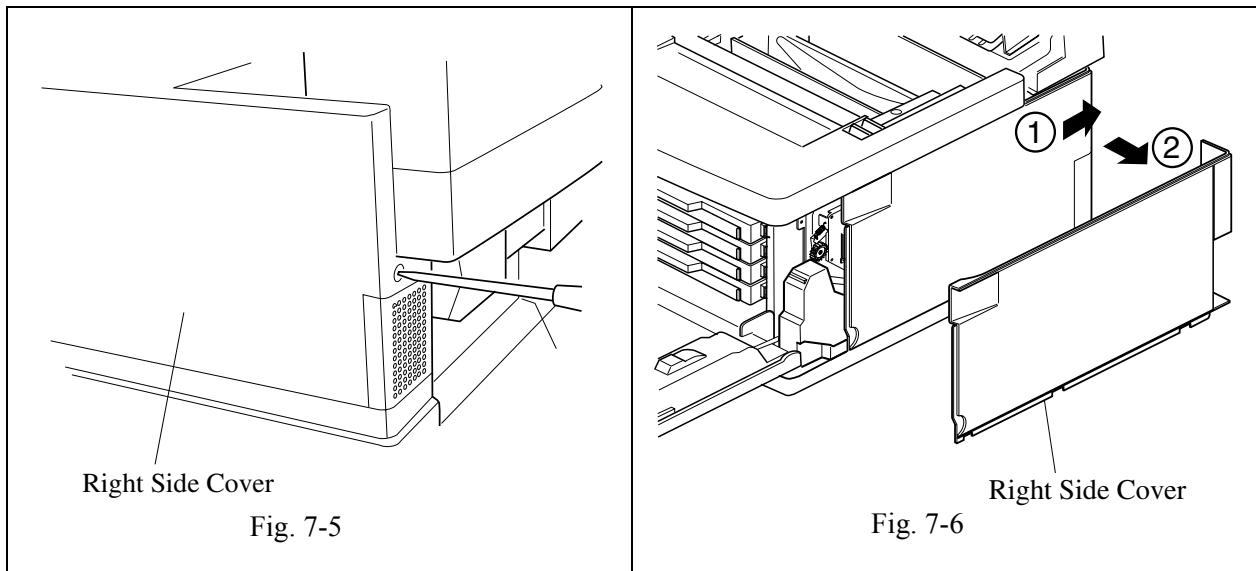

7.1.2.3 Assembly Procedures

1. Reinstall the right side cover in reverse order of disassembly.

7.1.3 Left Side Cover

7.1.3.1 Tools

#2 Phillips Screwdriver

7.1.3.2 Disassembly Procedures

(see Fig. 7-7)

1. Open the top door.
2. Remove the left-upper side cover (see section 7.1.1)
3. Remove two set screws (BT4X10) from the left side cover.
4. Remove the left side cover. Slowly pull up the left side cover, and unhook the hook from the top cover.

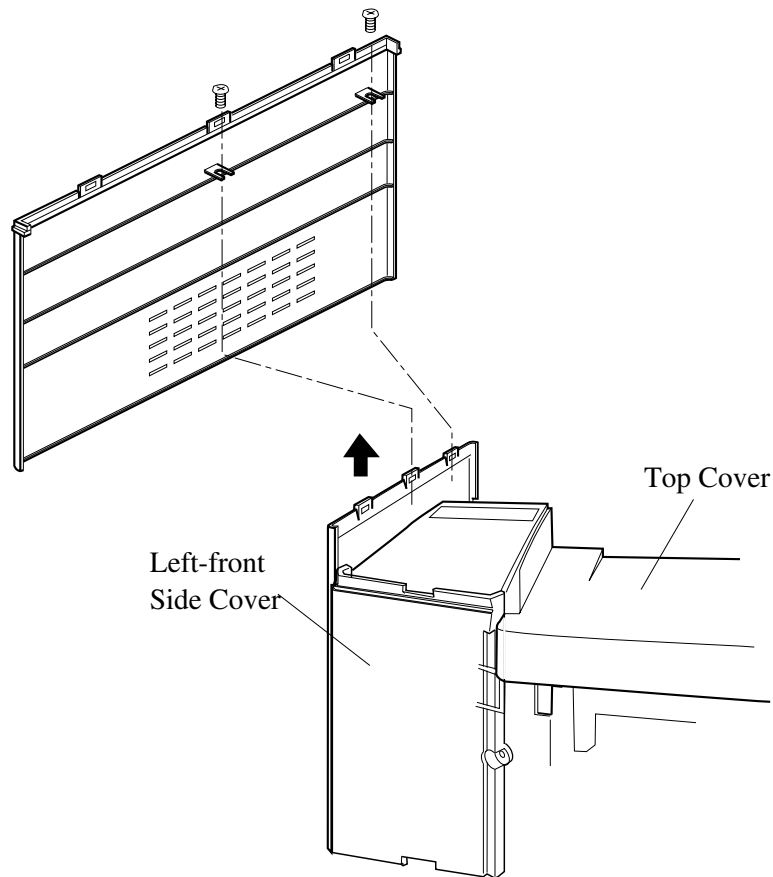

Fig. 7-7

7.1.3.3 Assembly Procedures

1. Reinstall the left side cover in reverse order of disassembly.

7.1.4 Left-front Side Cover

7.1.4.1 Tools

#2 Phillips Screwdriver

7.1.4.2 Disassembly Procedures

(see Fig. 7-8)

1. Open the top and front doors.
2. Remove the left-upper side cover (see section 7.1.2).
3. Remove the left side cover (see section 7.1.3).
4. Remove the top cover (see section 7.1.5).
5. Remove one set screw (TS4x8) from the left front side cover.
6. Pulling the left front side cover upward, remove the hook from the frame.
7. Remove the left front side cover.

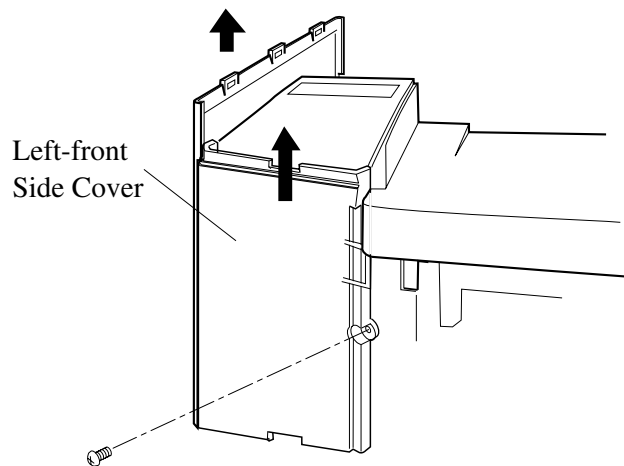

Fig. 7-8

7.1.4.3 Assembly Procedures

1. Reinstall in the reverse order of disassembly.

7.1.5 Top Cover

7.1.5.1 Tools

#2 Phillips Screwdriver

7.1.5.2 Disassembly Procedures

(see Fig. 7-9)

1. Open the front and top doors.
2. Remove the left-upper side cover (see section 7.1.1).
3. Remove the right side cover (see section 7.1.2).
4. Remove two screws (BT4X10) (upper side and at right side) from the left side cover.
5. Remove the top cover.

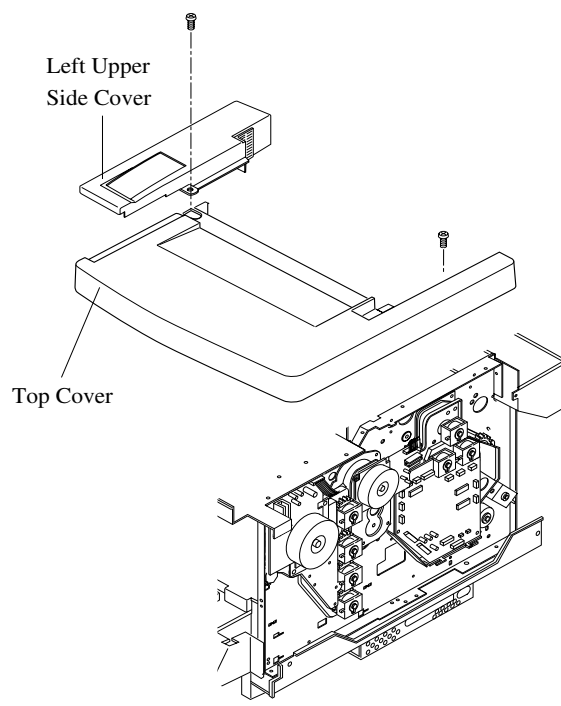

FIG 7-9

7.1.5.3 Assembly Procedures

1. Reinstall the top cover in reverse order of disassembly.

7.1.6 Paper Exit Cover / Paper Exit Front Cover

7.1.6.1 Tools

#1 and #2 Phillips Screwdrivers

7.1.6.2 Disassembly Procedures

(see Fig. 7-10)

1. Open the paper exit unit.
2. Remove the paper exit unit (see section 7.6.6).
3. Remove two set screws (BT3x8) and two set screws (ST3X6) from the paper exit front cover.
4. Remove the paper exit front cover from the paper exit unit.
5. Remove four set screws (BT3x12) from the paper exit cover.
6. Remove the paper exit cover assembly from the paper exit unit.

7.1.6.3 Assembly Procedures

1. Reassemble in reverse order of disassembly.

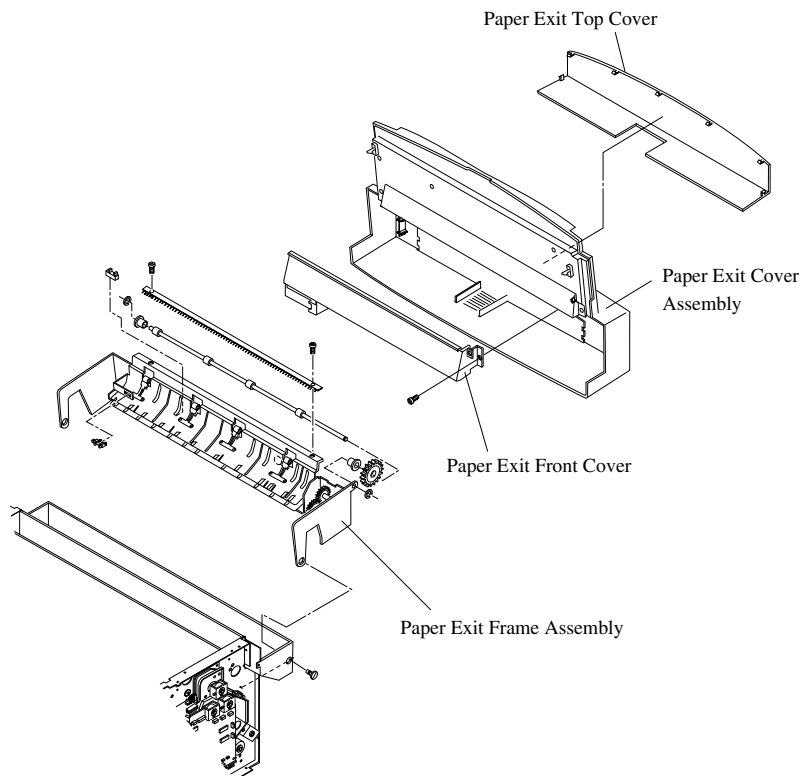

Fig. 7-10

7.1.7 Transfer Unit Door Cover

7.1.7.1 Tools

#1 and #2 Phillips Screwdrivers

7.1.7.2 Disassembly Procedures

(see Fig. 7-11)

1. Open the transfer unit.
2. Remove one fixing screw (BT4x10) from the band securing the transfer unit.
3. Holding the transfer unit horizontally, slide it out from the left edge of the TR support.
4. Remove the transfer unit.
5. Remove four fixing screws (BT3x8) from the back cover.
6. Remove the back cover from the transfer unit.

7.1.7.3 Assembly Procedures

1. Reassemble in reverse order of disassembly.

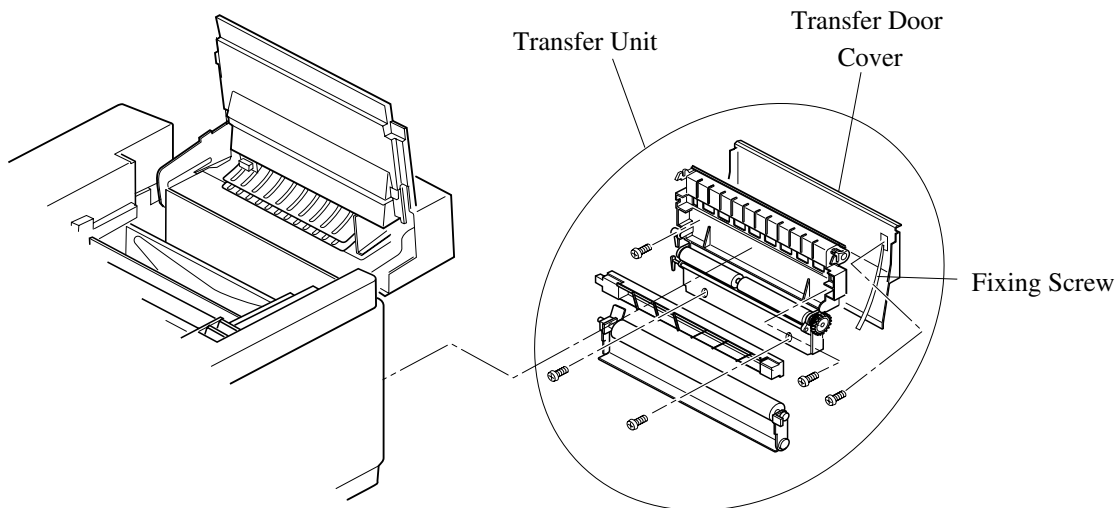

Fig. 7-11

7.1.8 Rear Cover

7.1.8.1 Tools

#2 Phillips Screwdriver

7.1.8.2 Disassembly Procedures

(see Fig. 7-12)

1. Unplug the power cable.
2. Remove one set screw (BT4x10) from the rear cover.

7.1.8.3 Assembly Procedures

1. Install a new rear cover.
2. Plug in the power cable.

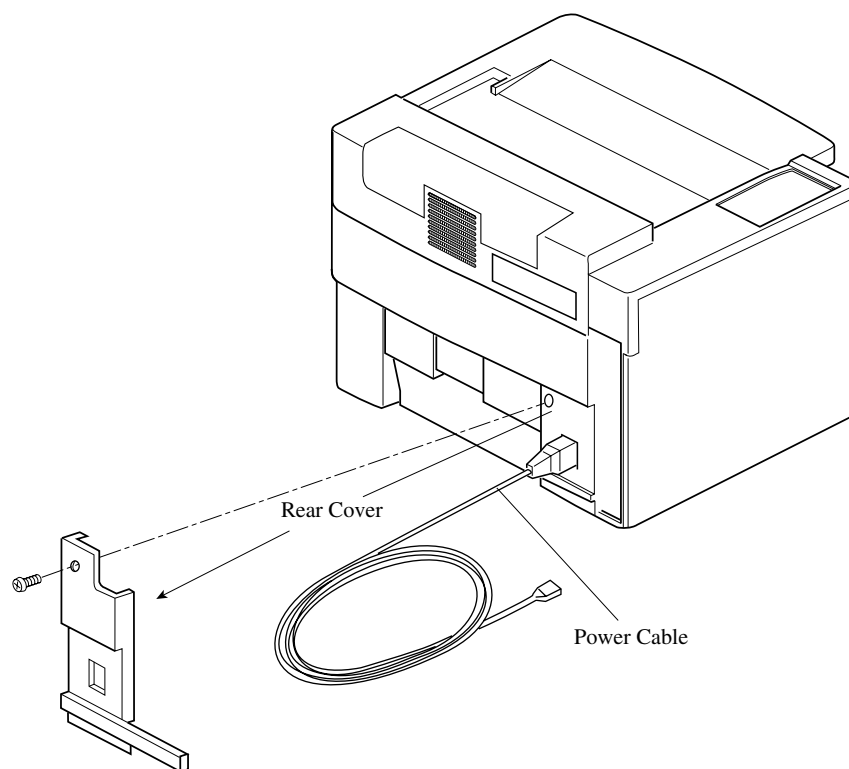

Fig. 7-12

7.1.9 Upper-rear Cover

7.1.9.1 Tools

#2 Phillips Screwdriver

7.1.9.2 Disassembly Procedures

(see Fig. 7-13)

1. Unplug the power cable from the outlet.
2. Open the transfer unit door.
3. Remove the right side cover (see section 7.1.2).
4. Remove the rear cover (see section 7.1.8).
5. Remove two hooks from the Upper-rear cover.
6. Remove the Upper-rear cover.

7.1.9.3 Assembly Procedures

1. Install a new upper rear cover.
2. Reassemble in reverse order of disassembly.

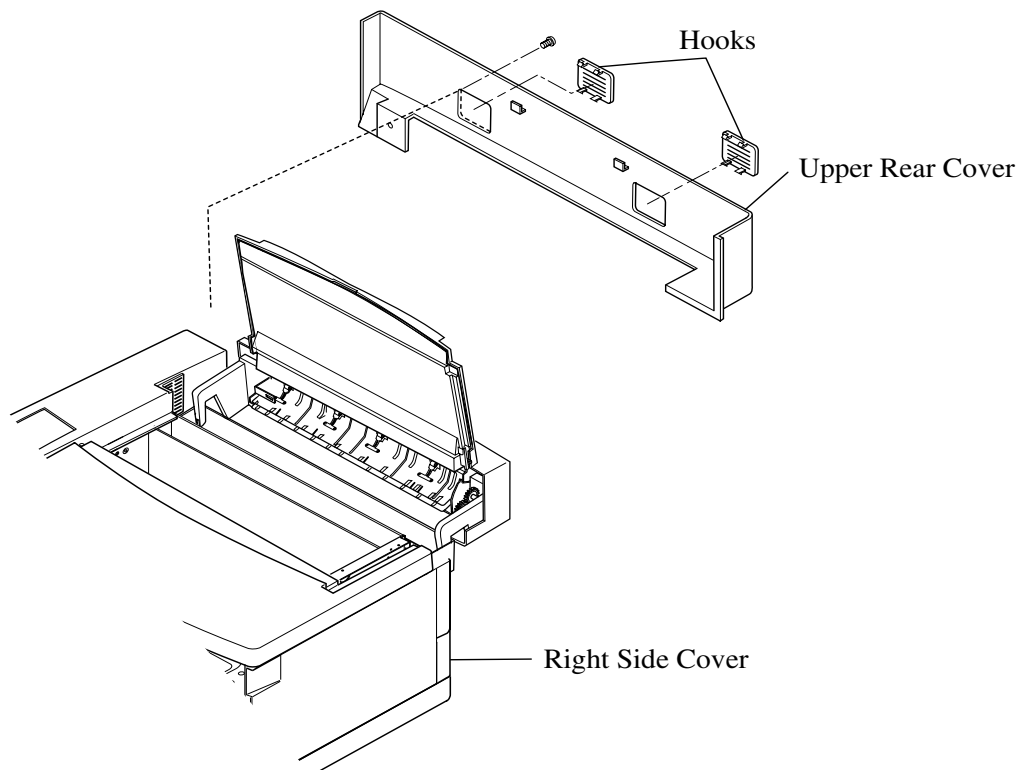

Fig. 7-13

7.1.10 Right Base Cover

7.1.10.1 Tools

#2 Phillips Screwdriver

7.1.10.2 Disassembly Procedures

(see Fig. 7-14)

1. Remove the right side cover (see section 7.1.2).
2. Remove two screws (BT4x10) from the right base cover.
3. Remove the right base cover from front to back.

7.1.10.3 Assembly Procedures

1. Reinstall the new right base cover in reverse order of disassembly.

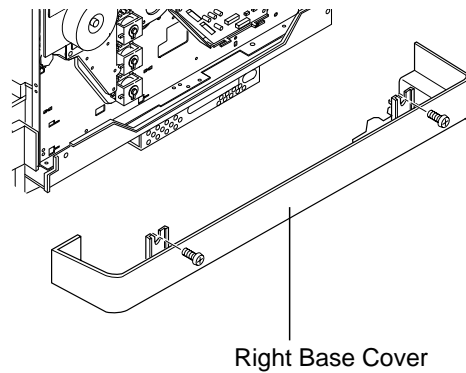

Fig. 7-14

CAUTION:

When assembling the base cover, insert the leading edge of right base cover into the two hooks located at the bottom (left and right) of the base plate (see Fig. 7-15).

Join the projecting part of right base cover meet the 3 hole locations in the base plate bottom (see Fig. 7-15).

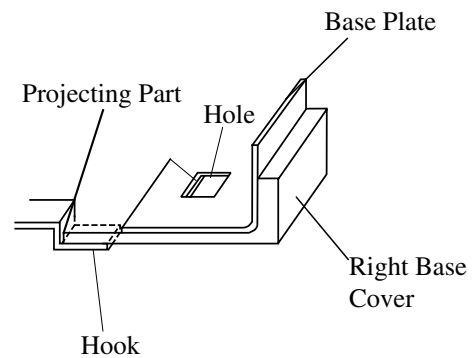

Fig. 7-15

7.1.11 Left Base Cover

7.1.11.1 Tools

#2 Phillips Screwdriver

7.1.11.2 Disassembly Procedures

(see Fig. 7-16)

1. Remove the left side cover (see section 7.1.3)
2. Remove two set screws (BT4x10) from the left base cover.
3. Remove the left base cover from front to back.

7.1.11.3 Assembly Procedures

1. Assemble the new left base cover in reverse order of disassembly.

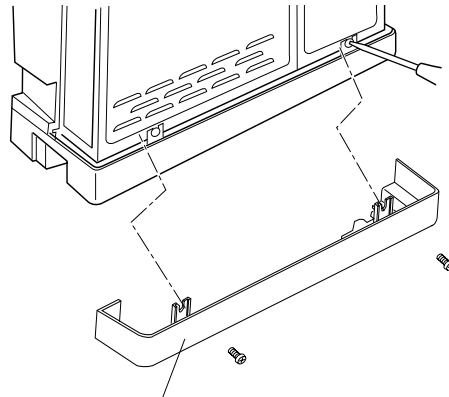

Left Base Cover

Fig. 7-16

CAUTION:

When assembling the base cover, insert the leading edge of left base cover into the two hooks at the bottom (left and right) of the base plate (see Fig. 7-17). Join the projecting part of left base cover to the 3 hole locations in the base plate bottom (see Fig. 7-17).

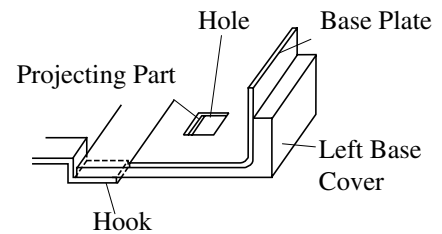

Fig. 7-17

7.1.12 Cleaner Cover

7.1.12.1 Tools

No special tools are required.

7.1.12.2 Disassembly Procedures

(see Fig. 7-18)

1. Open the top door.
2. Holding the tabs, remove the cleaner cover.

7.1.12.3 Assembly Procedures

1. Install a new cleaner cover.
2. Close the top door.

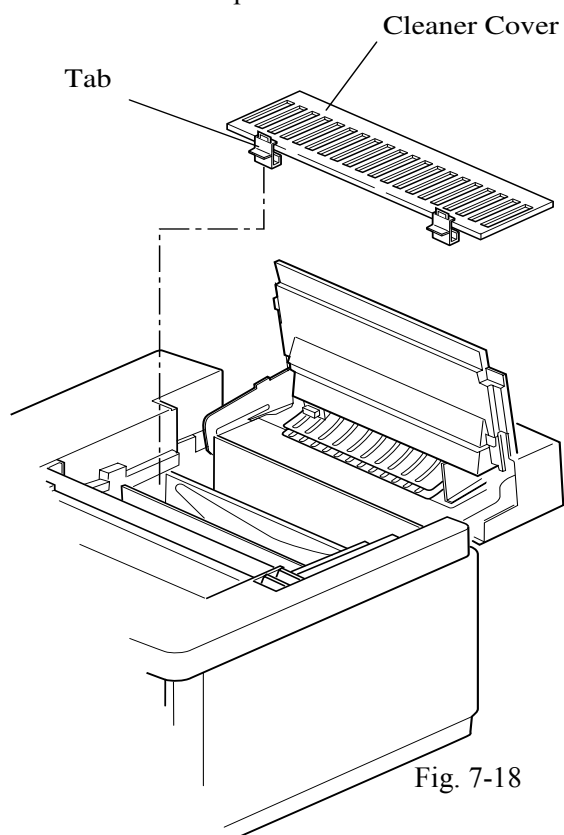

Fig. 7-18

7.1.13 Front Cover

7.1.13.1 Tools

#2 Phillips Screwdriver

7.1.13.2 Disassembly Procedures

(see Fig. 7-19 and Fig. 7-20)

1. Open the front door.
2. Remove two set screws (BT4x10) from the front cover.
3. Unhook the hook (5 locations, left and right), and remove the front cover from the front frame unit.

7.1.13.3 Assembly Procedures

1. Install the front cover to the front frame unit.
2. Attach the front cover with the two screws.

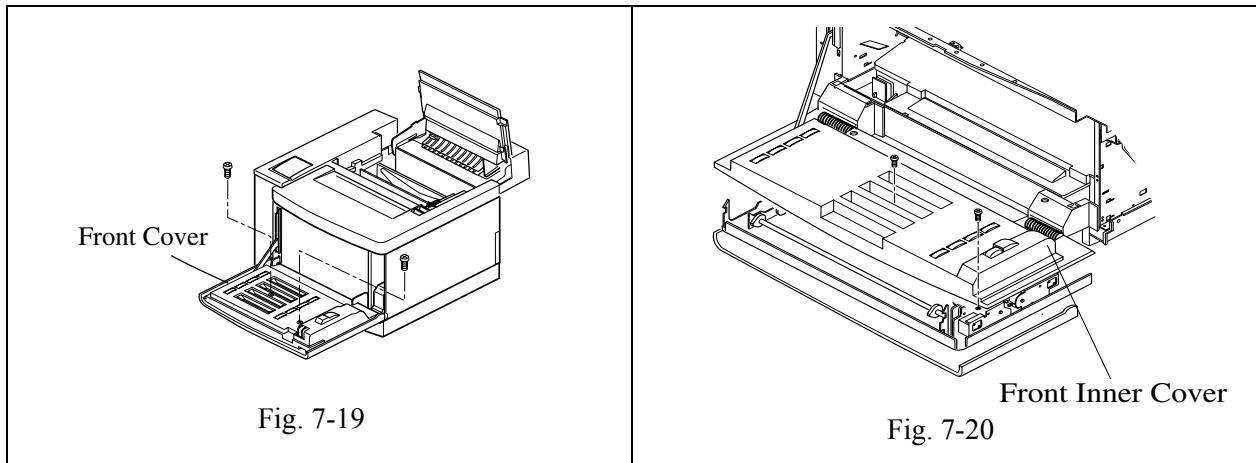

7.2 Replacement of Printed Wire Boards (P.W.B)
Layout of Printed Wire Boards

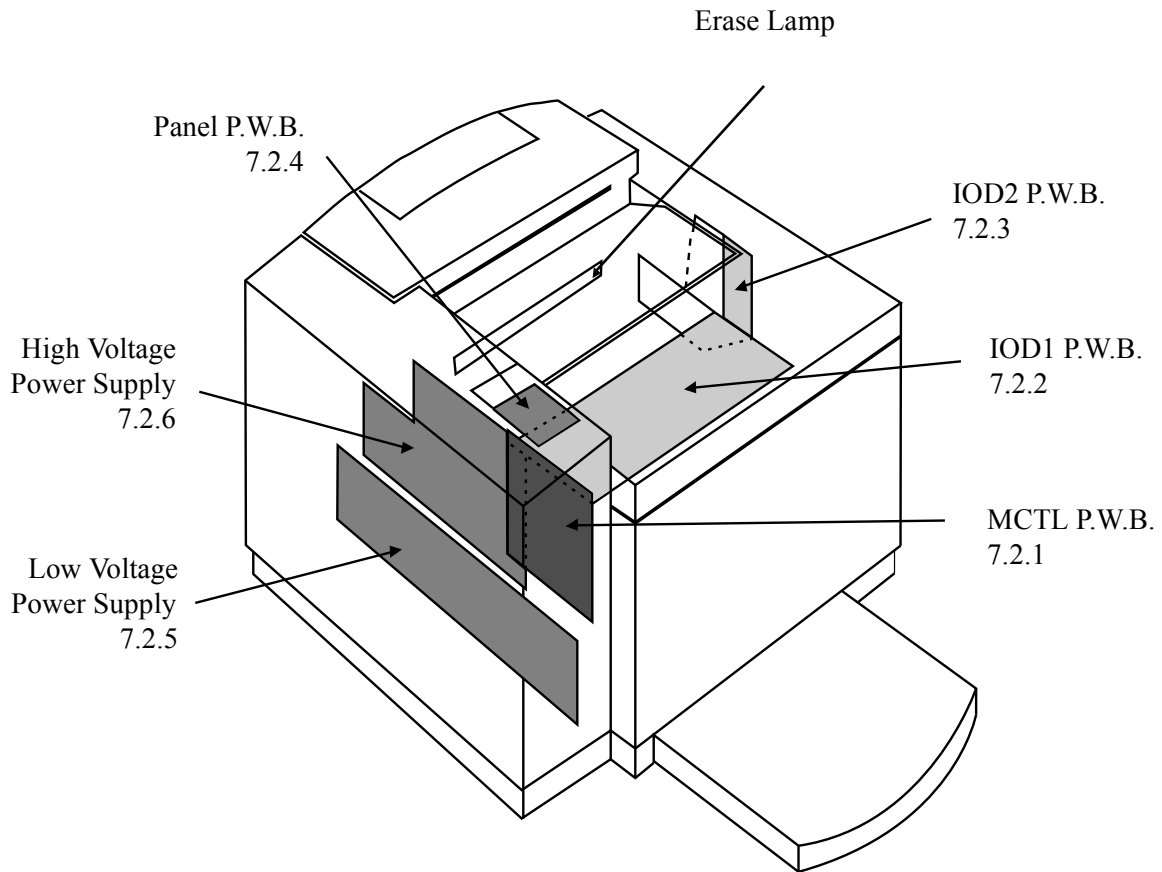

Fig. 7-21

7.2.1 MCTL P.W.B.

7.2.1.1 Tools

Phillips Screwdrivers #1 and #2

CAUTION

Read the information contained in the NVRAM prior to replacing the MCTL P.W.B.

When handling the MCTL P.W.B. use E.S.D. handling precautions.

7.2.1.2 Disassembly Procedures

(see Fig. 7-22)

1. Remove the upper-left side cover (see section 7.1.1).
2. Remove the left side cover (see section 7.1.3).
3. Remove one set screw (TS3x6) from the shield cover B.
4. Disconnect seven harness connectors connected to the MCTL.
5. Remove four set screws (TS3x6) from the MCTL.
6. Remove the MCTL.

7.2.1.3 Assembly Procedures

1. Assemble a new MCTL P.W.B.
2. After above assembling, follow the reverse order of above disassembly procedures.
3. Upon completion of the set-up, connect the power supply cable.
4. Turn on the power switch of the printer.
5. Execute the RAM Clear in Service Mode.
6. Input content of RAM before replacement in Service Mode (see section 6.5.2).
7. Confirm the operation and print quality by implementing the test print.
8. Input the previous information (before replacement) to the RAM of MCTL P.W.B. as necessary (see section 6.4 for the details).

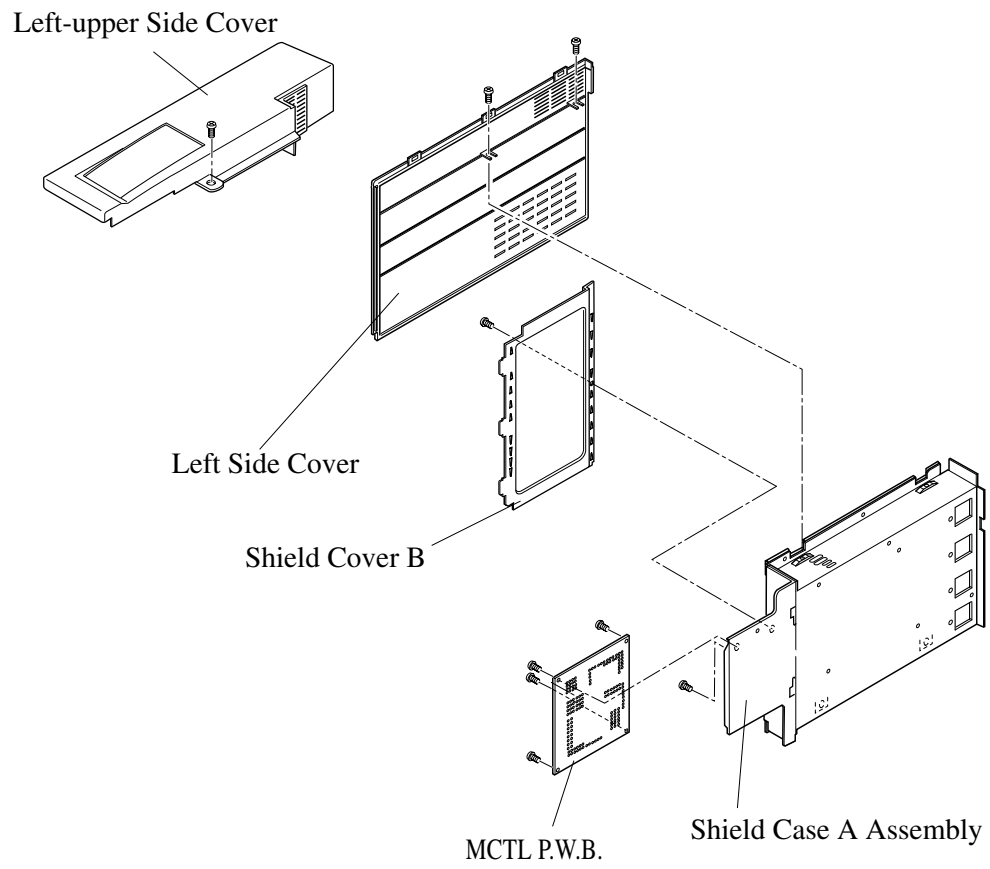

Fig. 7-22

7.2.2 IOD1 P.W.B.

7.2.2.1 Tools

Phillips Screwdrivers #1 and #2

CAUTION:

When handling any P.W.B. use ESD precautions.

7.2.2.2 Disassembly Procedures

(see Fig. 7-23)

1. Remove the left-upper side cover (see section 7.1.1).
2. Remove the top cover (see section 7.1.5).
3. Remove four set screws (ST3x6) from the shield (upper).
4. Remove the shield (upper).
5. Disconnect all the harness connectors (14 pcs.) connected with the IOD1 P.W.B.
6. Remove six set screws (ST3x6) of IOD1 P.W.B.
7. Remove the IOD1 P.W.B.

7.2.2.3 Assembly Procedures

1. Assemble a new IOD1 P.W.B. Remove the factory plug located at DCN3 from the old IOD1 P.W.B. and install it on the new IOD1 P.W.B.
2. Reinstall in reverse order of disassembly.
3. Upon completion of assembly, connect the power supply cable.
4. Turn on the power switch of the printer.
5. Execute the test print in Service Mode.
6. Confirm the operation and print quality of printer.

CAUTION

When replacing the IOD1 P.W.B, pay attention that no damage is caused by electrostatic charge.

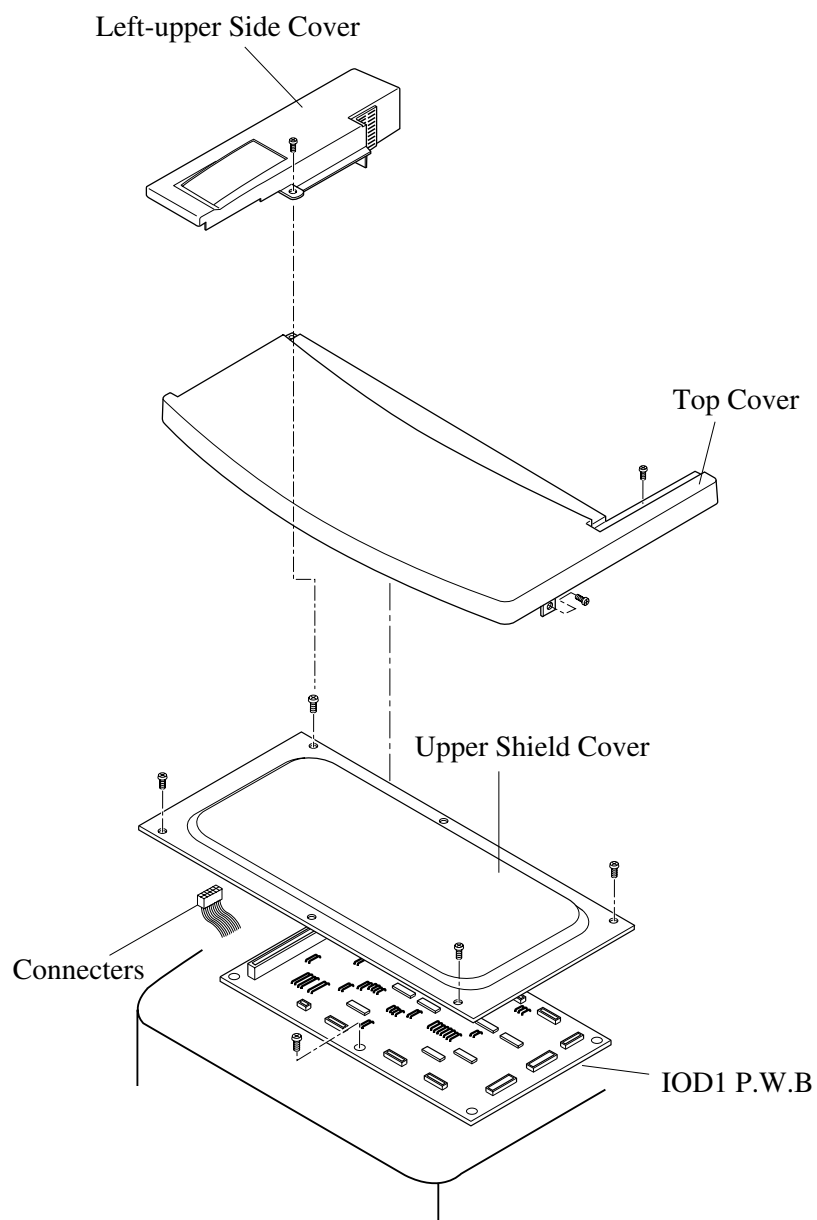

Fig. 7-23

7.2.3 IOD2 P.W.B.

7.2.3.1 Tools

Phillips Screwdrivers #1 and #2

CAUTION:

When handling any P.W.B. use ESD precautions.

7.2.3.2 Disassembly Procedures

(see Fig. 7-24)

1. Remove the right side cover (see section 7.1.2).
2. Remove 16 harnesses connected to the IOD2 P.W.B.
3. Remove one fixing screw (ST3x6) from the IOD2 P.W.B with base.
4. Remove the IOD2 P.W.B from the engine. The IOD2 P.W.B is fixed by hooks at 3 locations.

7.2.3.3 Assembly Procedures

1. Reinstall in reverse order of disassembly.
2. Connect the power supply cable.
3. Turn on the power supply switch of printer.
4. Run the test print in the service mode.
5. Confirm the printer operation and print quality.

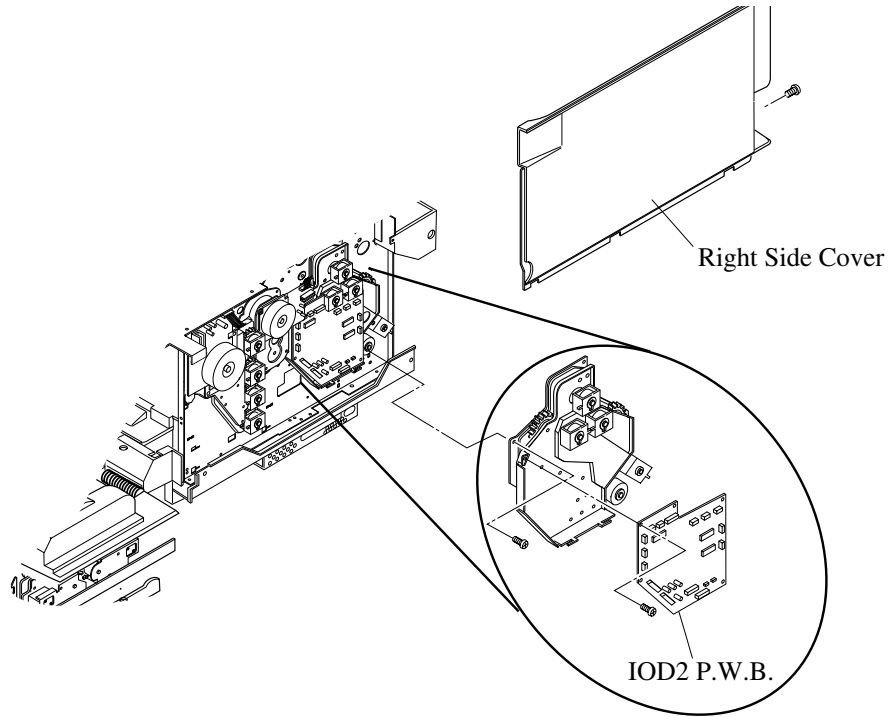

Fig. 7-24

7.2.4 Panel P.W.B. (LCD inclusive)

7.2.4.1 Tools

Phillips Screwdrivers #1 and #2

CAUTION:

When handling any P.W.B. use ESD precautions.

7.2.4.2 Disassembly Procedures

(see Fig. 7-25)

1. Remove the left-upper side cover (see section 7.1.1).
2. Remove the set screw [SP4x9 (1 pc.)] from the panel case assembly.
3. Disconnect the connector.
4. Remove four set screws (BT3x8) from the panel P.W.B. and LCD from the panel case assembly.
5. Upon removal of the panel P.W.B., and the shield plate, remove the panel button and panel shield as shown in Fig. 7-25.

7.2.4.3 Assembly Procedures

1. Assemble a new panel P.W.B. (LCD inclusive) in the panel case.
2. Install each part that has been removed in the disassembly procedures.
3. Connect the connector.
4. Install the panel case to the top cover.
5. Connect the power supply cable.
6. Turn on the power switch of the printer.
7. Execute the test print in Service Mode.
8. Confirm the panel switch and indicator.

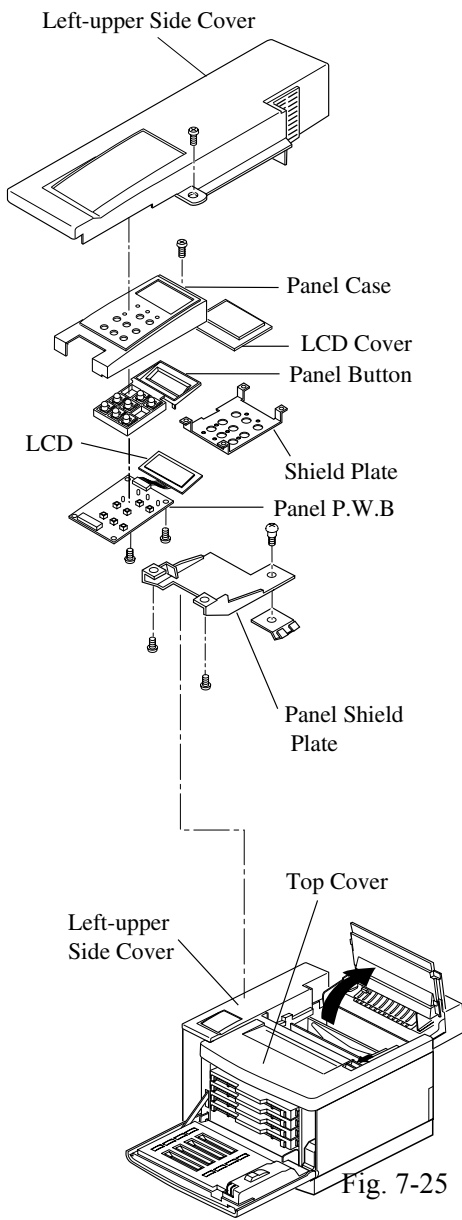

Fig. 7-25

7.2.5 Low Voltage Power Supply (LVPS)

7.2.5.1 Tools

Phillips Screwdrivers #1 and #2
Slotted Screwdriver #1

CAUTION:

When handling any P.W.B. use ESD precautions.

7.2.5.2 Disassembly Procedures

(Fig. 7-26)

1. Remove the left-upper side cover (see section 7.1.1).
2. Remove the left side cover (see section 7.1.3).
3. Remove the left-front side cover (see section 7.1.4).
4. Remove two screws (ST3x6) from the shield cover B.
5. Remove three screws (ST3x6) from the shield cover A.
6. Remove the upper shield cover.
7. Remove the switch button.
8. Remove two screws (ST3x6) from the shield cover F.
9. Disconnect all the harness connectors connected to the MCTL P.W.B.
10. Remove the left base cover (see section 7.1.11).
11. Remove one screw (ST3x6) from the controller fan assembly; remove the fan.
12. Remove four set screws (ST3x6) from the shield case A assembly.
13. Remove the shield case A assembly, and then, the power supply duct.
14. Remove the rear cover (see section 7.1.8).
15. Remove three set screws (ST3x6) from the right-bottom stay (R).
16. Disconnect five harness connectors connected to the LVPS.
17. Remove two set screws (ST3x6) from the outlet base.
18. Remove the set screw (M4x6 brass, with washer) from the ground wire.
19. Remove three set screws (ST3x6) from the LVPS.
20. Remove the LVPS from the printer engine.

7.2.5.3 Assembly Procedures

1. Reinstall the LVPS in reverse order of disassembly
2. Confirm the ground wire is connected to the frame.
3. Connect the power supply cable.
4. Turn the power supply switch On.
5. Confirm the print operation and print quality.

WARNING

The ground wire is very important to the safety of users. Upon removal of the LVPS, confirm that the ground wires (green and yellow color) are securely connected to grounding point.

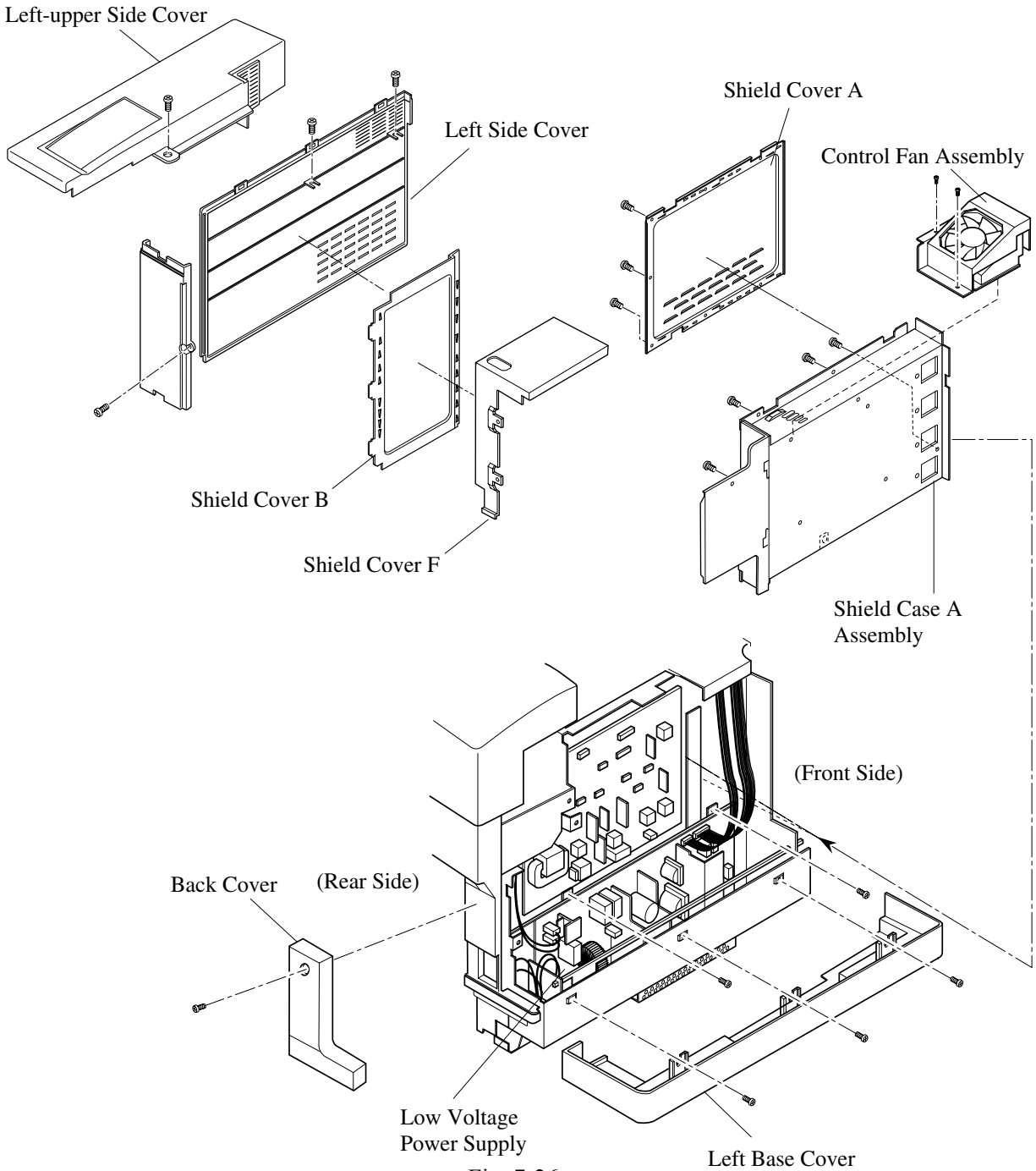

Fig. 7-26

7.2.6 High Voltage Power Supply (HVPS)

7.2.6.1 Tools

Phillips Screwdrivers #1 and #

CAUTION:

When handling any P.W.B. use ESD precautions.

7.2.6.2 Disassembly Procedures

(see Fig. 7-27)

1. Remove the left-upper side cover (see section 7.1.1).
2. Remove the left side cover (see section 7.1.3).
3. Remove the shield cover A.
4. Remove the shield cover B.
5. Disconnect seven harness connectors connected from the MCTL P.W.B.
6. Remove one screw (ST3x6); remove the controller fan assembly, including the case (see section 7.1.3).
7. Remove four set screws (ST3x6) from the shield case A assembly.
8. Remove the power supply fan duct.
9. Disconnect four harness connectors connected to the high voltage power supply.
10. Remove one set screw (ST3x6) and eight tapping screws (BT3x8) from the high voltage power supply and remove the HVPS.

7.2.6.3 Assembly Procedures

1. Install a new HVPS.
 - a. When installing the unit, pull each electrode terminal through the holes of P.W.B. from the back.
 - b. Align the set holes for the electrode to the installation hole of P.W.B, affix both with a screw.
2. Assemble the high voltage power supply (HVPS) in reverse order of disassembly.
3. Connect the power supply cable and turn the power switch On.
4. Run a test print in Service Mode to confirm the printing operation and print quality.

WARNING

The High Voltage Power Supply generates high voltage (5kV). You may get shocked if you touch the unit while it is powered on. Therefore, turn on the unit only after having installed the left side cover.

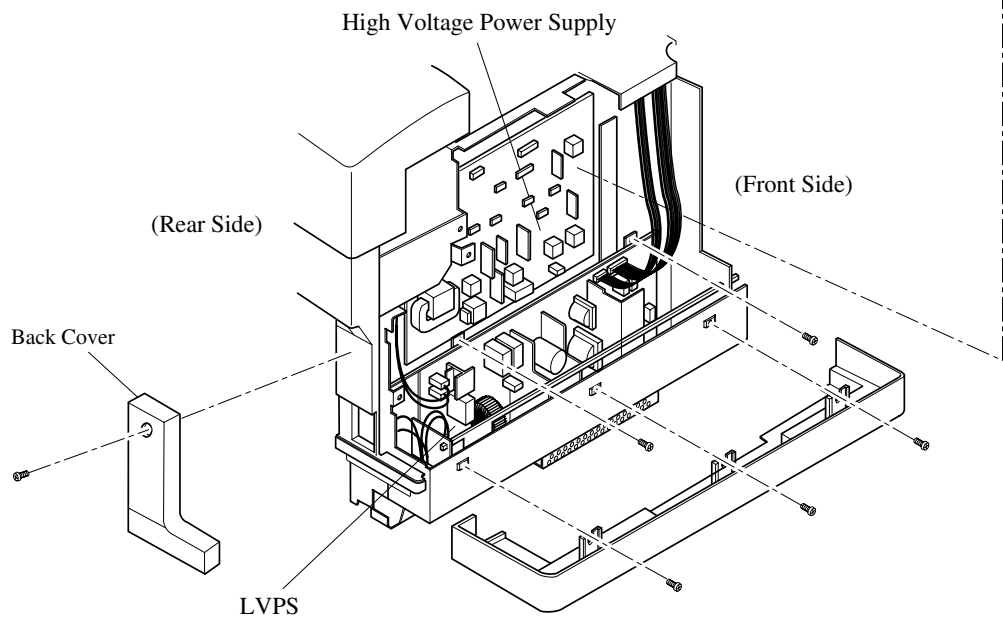
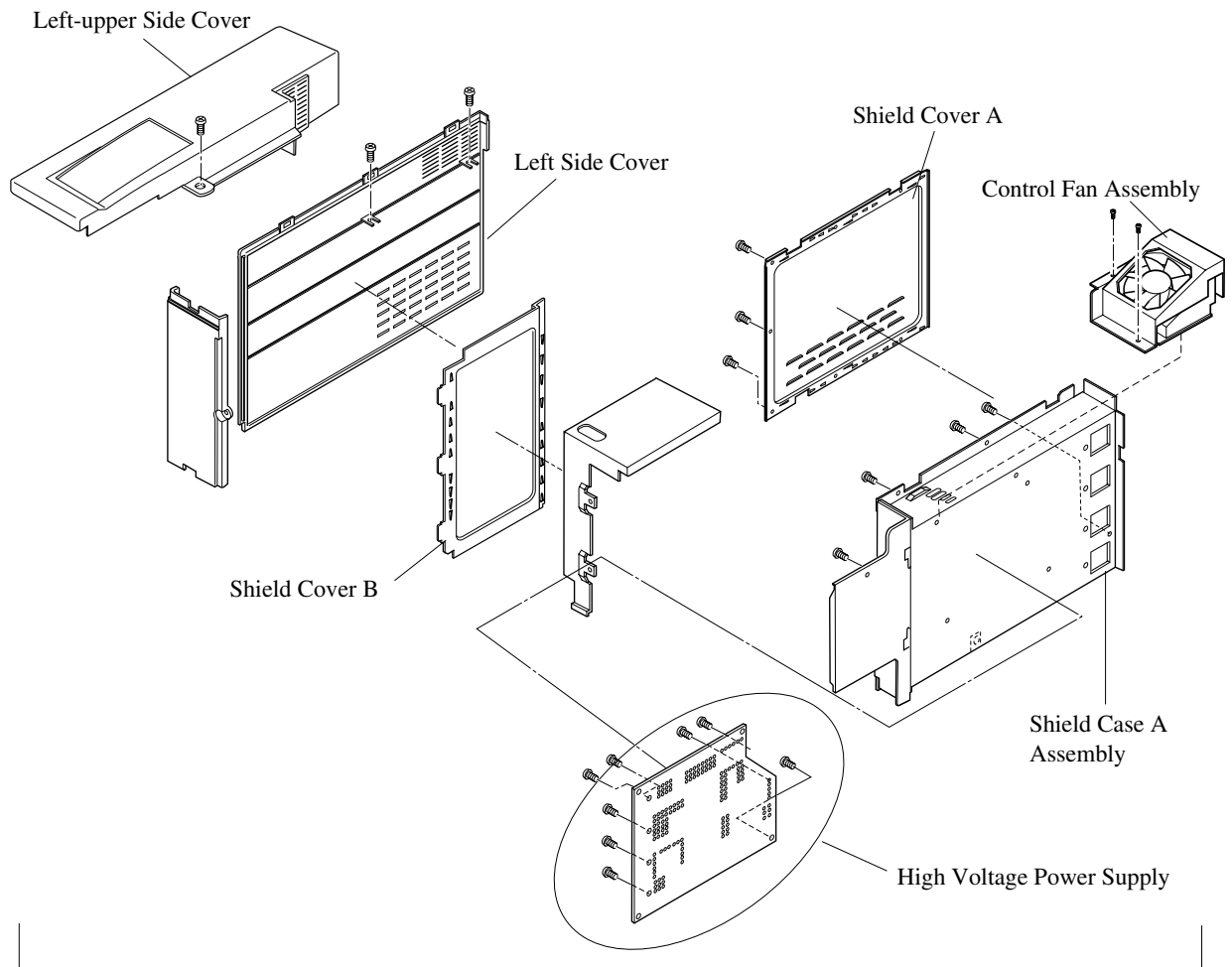

Fig. 7-27

7.2.7 Erase Lamp

7.2.7.1 Tools

No special tools are required.

CAUTION:

When handling any P.W.B. use ESD precautions.

7.2.7.2 Disassembly Procedures

(see Fig. 7-28)

1. Open the front and top doors.
2. Remove the toner cartridges and the belt cartridge.
3. Remove the erase lamp P.W.B. from the holder (3 locations) at the front side.
4. Disconnect the connection of erase lamp harness connector.
5. Remove the erase lamp.

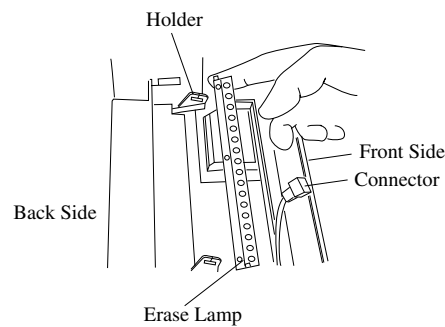

Fig. 7-28

7.2.7.3 Assembly Procedures

1. Install the erase lamp into the base frame.
2. Reassemble all items in reverse order of disassembly.
3. Connect the power supply cable.
4. Turn the power supply switch On.
5. Run a test print in Service Mode.
6. Confirm the print operation and print quality.

CAUTION

The erase lamp has directional characteristics. If it is installed in the wrong direction, the transfer drum may be damaged.

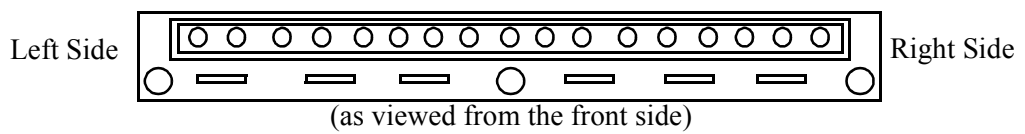

Fig. 7-29

7.3 Replacement of Motor Units
Layout of Motors

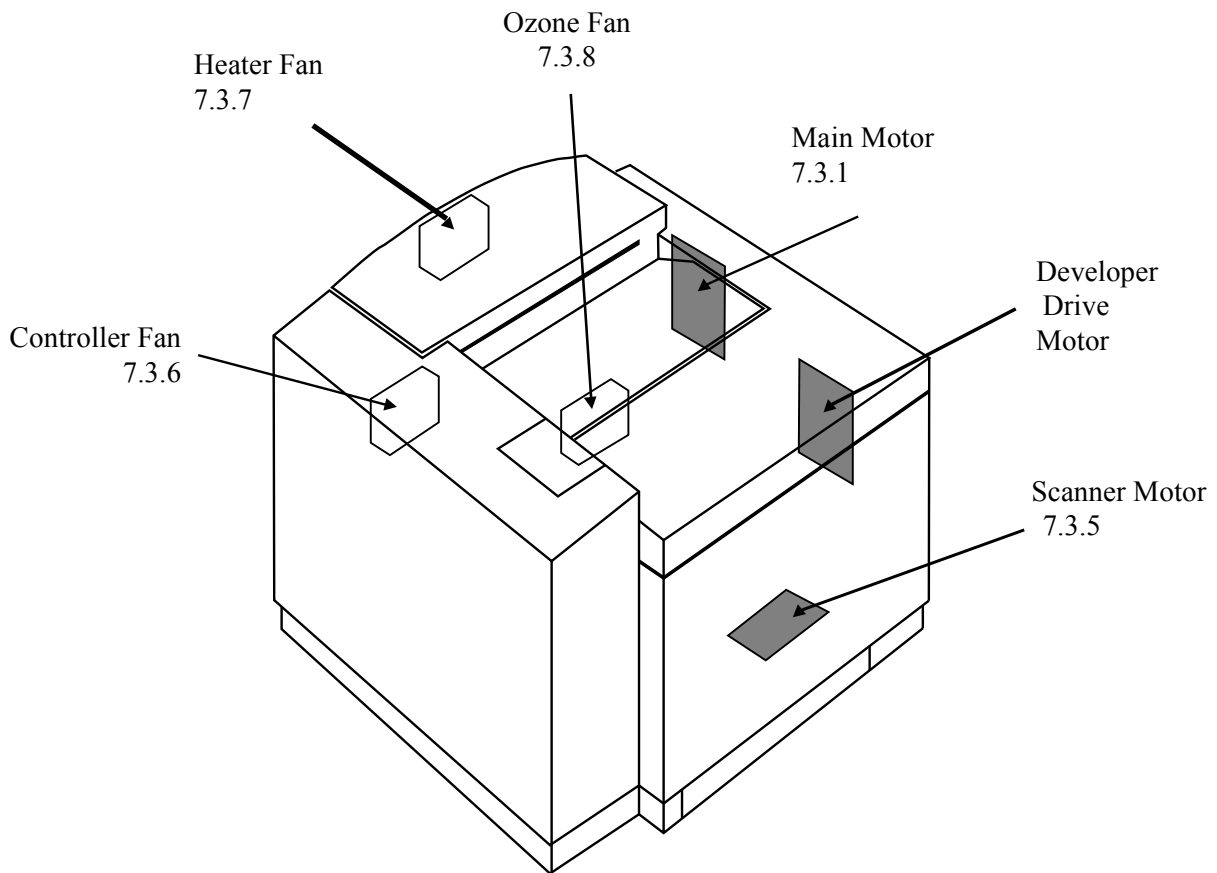

Fig. 7-30

7.3.1 Main Motor / Main Motor Assembly

7.3.1.1 Tools

#1 Phillips Screwdriver

7.3.1.2 Disassembly Procedures

(see Fig. 7-31)

1. Remove the right side cover (see section 7.1.2).
2. Remove the top cover (see section 7.1.5).
3. Remove the connector connected with the main motor.
4. Remove three fixing screws (ST3x6) from the main motor assembly.
5. Remove the main motor assembly from the frame.
6. Remove four fixing screws (ST3x6) from the main motor.
7. Remove the main motor from the main motor assembly. Separate the motor and BD Gear Unit.

7.3.1.3 Assembly Procedures

1. Install the main motor assembly to the engine frame.
2. Reassemble in reverse order of disassembly.

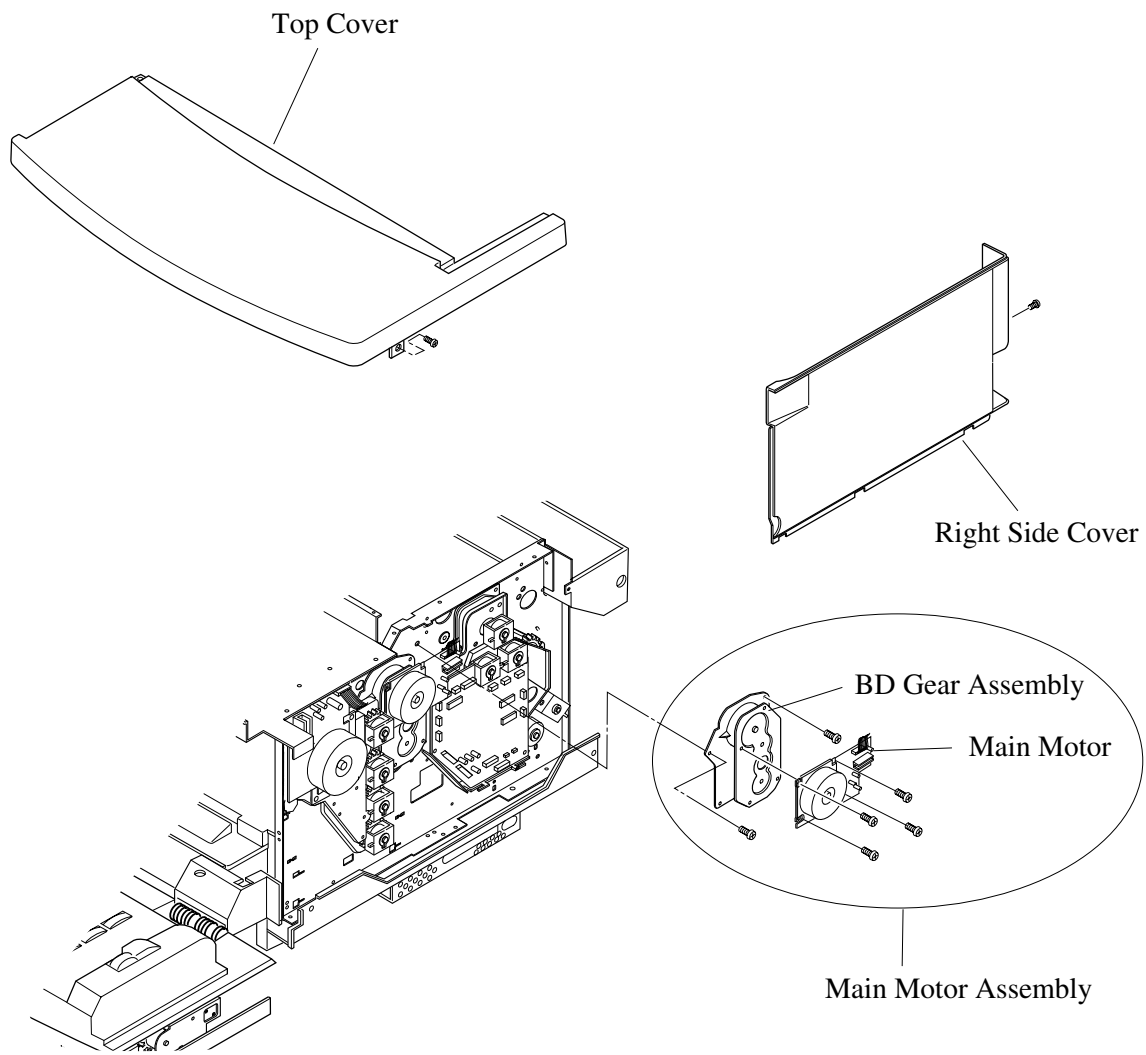

Fig. 7-31

7.3.2 Main Gear Unit

7.3.2.1 Tools

Phillips Screwdrivers #1 and #2
Small Screwdriver

7.3.2.2 Disassembly Procedures

(see Fig. 7-32)

1. Remove the fuser.
2. Remove the main motor assembly (see section 7.3.1).
3. Remove the right base cover (see section 7.1.10).
4. Remove the IOD2 P.W.B. (see section 7.2.3).
5. Remove the ozone fan duct assembly (see section 7.3.8).
6. Remove four set screws (ST3x6) from the main drive unit.
7. Remove the main gear unit from the frame.

7.3.2.3 Assembly Procedures

1. Install the main drive unit on the engine frame.
2. Reassemble in reverse order of disassembly.

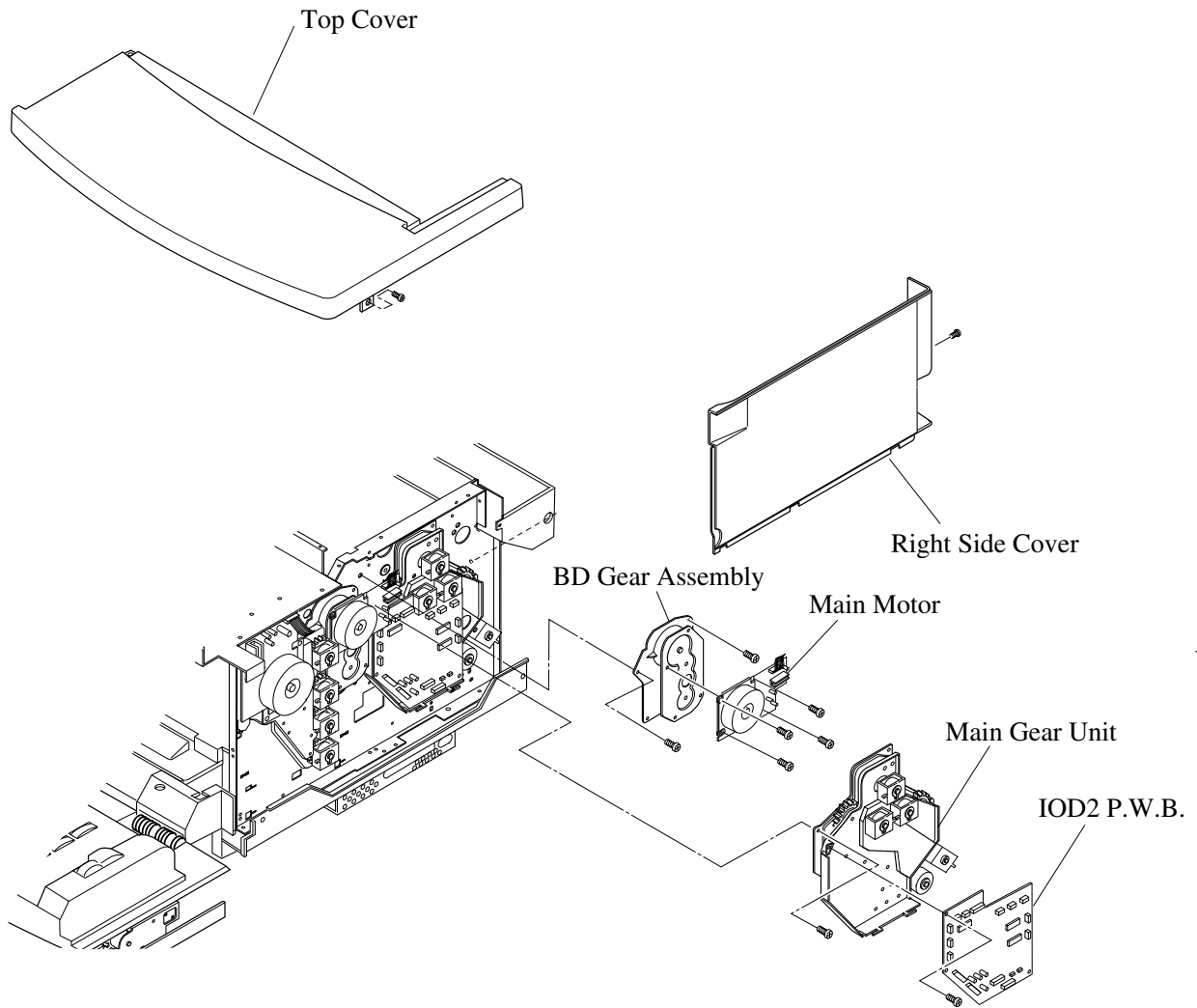

Fig. 7-32

7.3.3 Developer Motor (DM)

7.3.3.1 Tools

#1 Phillips Screwdriver
Small Screwdriver

7.3.3.2 Disassembly Procedures (see Fig. 7-33)

1. Remove the toner cartridge.
2. Remove the top cover.
3. Disconnect one connector (CN1) from the developer motor P.W.B.
4. Remove four fixing screws (ST3x6) from the developing motor.
5. Remove the developing motor from the developer driving unit.

7.3.3.3 Assembly Procedures

1. Reassemble in reverse order of disassembly.

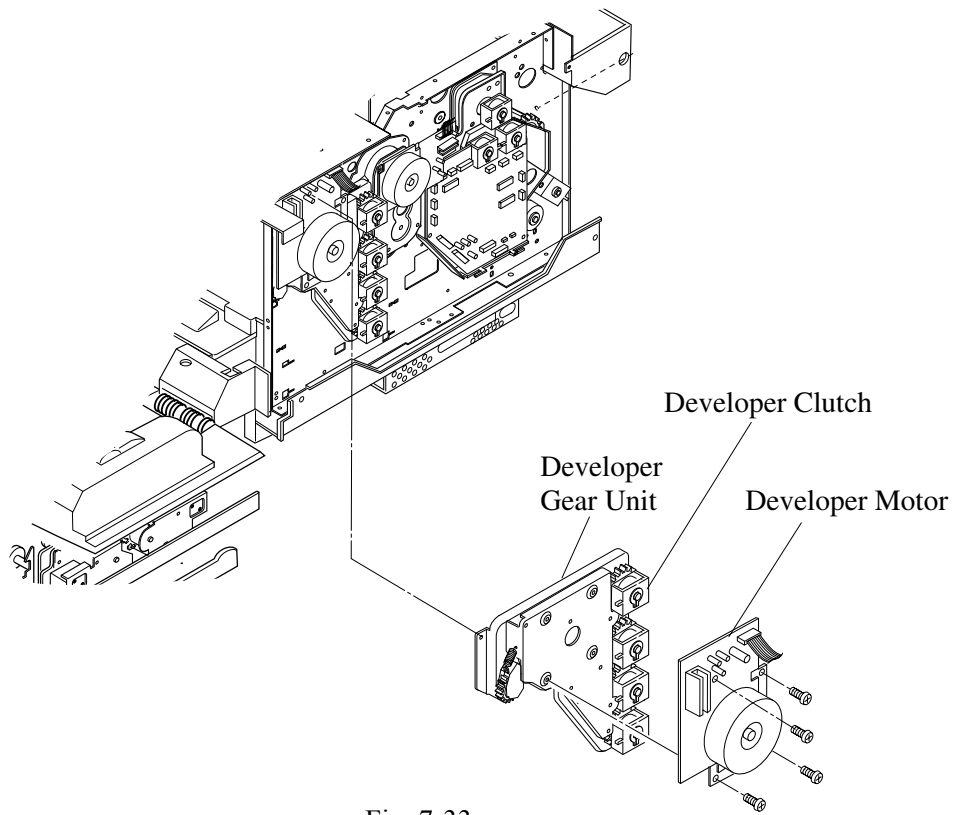

Fig. 7-33

7.3.4 Developer Gear Unit

7.3.4.1 Tools

Phillips Screwdrivers #1 and #2
Small Screwdriver

7.3.4.2 Disassembly Procedures

(see Fig. 7-34)

1. Remove the toner cartridge.
2. Remove the waste toner bottle.
3. Remove the top cover (see section 7.1.5).
4. Remove one screw (ST3x6) from the back cover (RF); remove the back cover (RF).
5. Remove two screws [one set screw (ST3x6), and one screw (ST4x6)] from the front stay (R) RF.
6. Remove one set screw (ST3x6) from the waste toner bottle holder.
7. Remove the waste toner bottle holder.
8. Disconnect the connectors between the developer motor and the IOD2 where each clutch is connected.

Note: When removing the developer gear, special spacers on the toner shafts may fall out.

9. Remove three set screws (ST3x6) from the developer gear unit and remove one set screw (ST3x6) from the MD stopper.
10. Remove the developer gear unit from the frame.

7.3.4.3 Assembly Procedures

1. Install the clutches and cam clutches to the developer gear unit.
2. Reassemble in reverse order of disassembly.

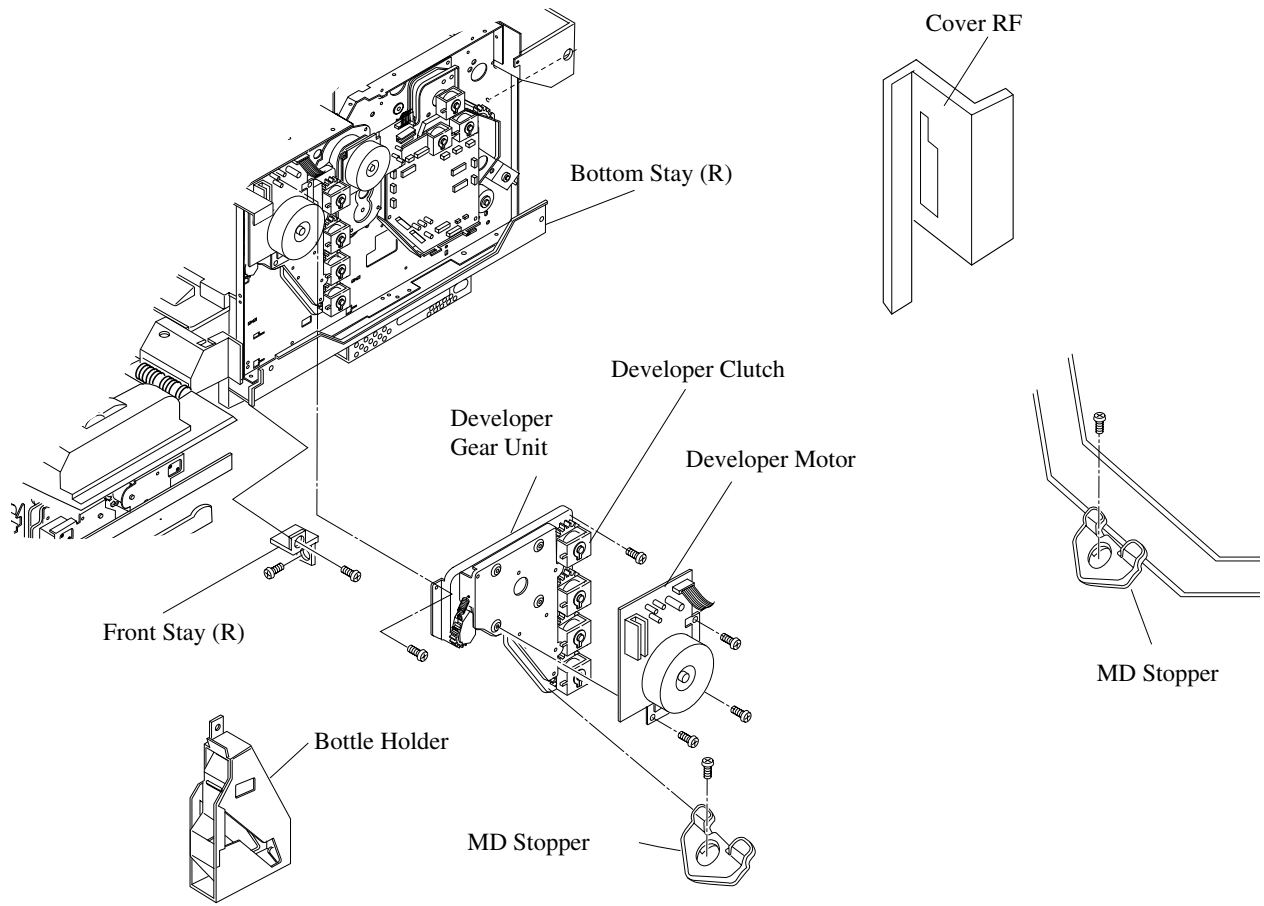

Fig. 7-34

7.3.5 Optical Unit (Including Scanner Motor)

7.3.5.1 Tools

Phillips Screwdrivers #1 and #2

7.3.5.2 Disassembly Procedures

(see Fig. 7-35)

1. Remove the toner cartridge.
2. Remove the belt cartridge.
3. Remove two fixing screws (ST3x6) from cover "C".
4. Pull the cover "C" toward you and remove the cover from the inside of printer. Unlatch the hooks (2 locations) at the front side.
5. Remove three fixing screws (ST3x6) from the optical unit.
6. Disconnect the connector from the optical unit.
7. Remove the optical unit from the inside of printer.

7.3.5.3 Assembly Procedures

1. Install the new optical unit onto the printer base.
2. Reassemble in reverse order of disassembly.

CAUTION:

There is a Class IIIa laser within the optical unit. Do not attempt to disassemble the optical unit.

The optical unit is replaced as a whole unit; no adjustment is required.

Confirm that all the covers have been installed before testing or operating the printer. This will prevent accidental laser exposure.

Laser WARNING Label

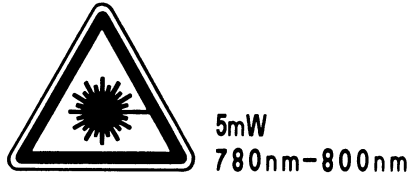

DANGER – INVISIBLE LASER RADIATION WHEN OPEN.
AVOID DIRECT EXPOSURE TO BEAM.

VORSICHT–UNSICHTBARE LASERSTRAHLUNG. WENN ABDECKUNG
GEÖFFNET UND SICHERHEITVERRIEGELUNG
ÜBERBRÜCKT. NICHT DEM STRAHL AUSSETZEN.

DANGER – RAYON LASER INVISIBLE LORS DE L'OUVERTURE.
EVITER L'EXPOSITION DIRECTE.

PELIGRO – RADIACION LASER INVISIBLE AL ABRIR. EVITAR
LA EXPOSICION DIRECTA AL HAZ.

危険 開けたときレーザー放射の危険あり。
ビームに直接当たらないように注意して下さい。 **MAS**

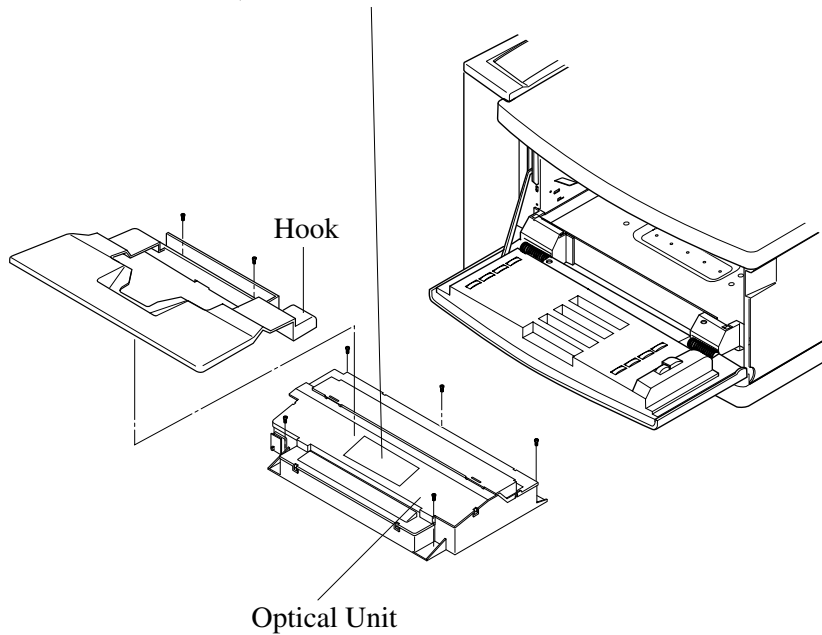

Fig. 7-35

7.3.6 Controller Fan (CTFAN)

7.3.6.1 Tools

#1 Phillips Screwdriver

7.3.6.2 Disassembly Procedures

(see Fig. 7-36 and Fig. 7-37)

1. Remove the left-upper side cover (see section 7.1.1).
2. Remove the left side cover (see section 7.1.3).
3. Remove the top cover (see section 7.1.5).
4. Remove the upper shield cover by removing 4 screws (ST3x6).
5. Remove one set screw (ST3x6) from the control fan case.
6. Disconnect the harness connector (IOD1 CN) from the controller fan.
7. Open the fan case by unhooking one latch, and remove the fan motor.

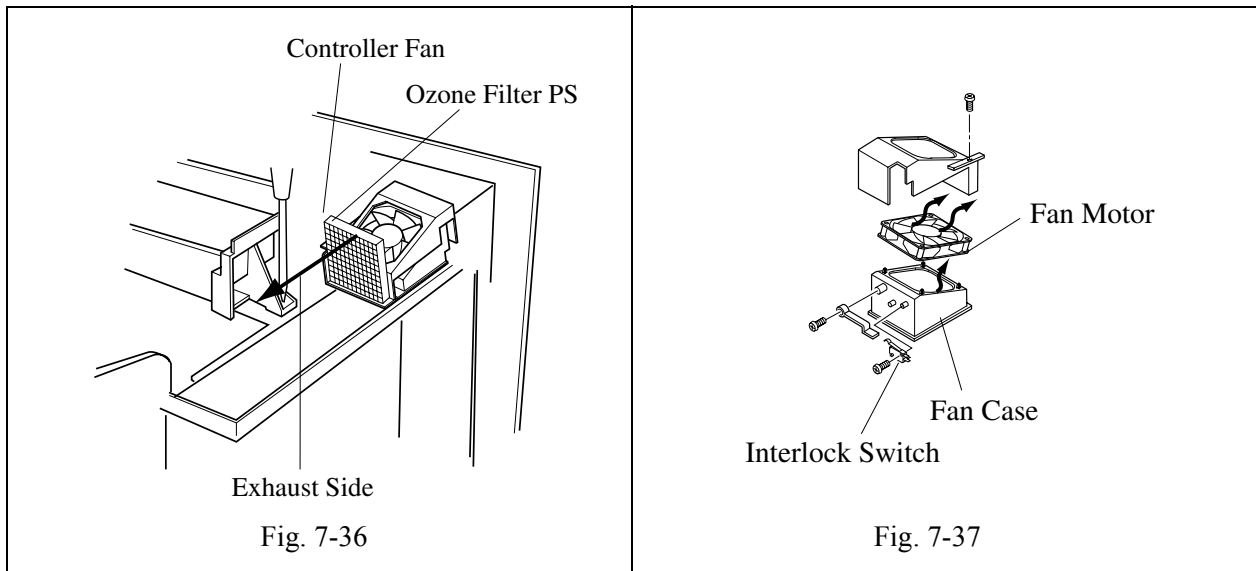

7.3.6.3 Assembly Procedures

1. Install the fan motor into the fan case.
2. Reassemble in reverse order of disassembly.

7.3.7 Heater Fan (HTFAN)

7.3.7.1 Tools

#1 Phillips Screwdriver

7.3.7.2 Disassembly Procedures

(see Fig. 7-38)

1. Remove the paper exit front cover (see section 7.1.6).
2. Remove the fuser fan motor from the paper exit frame assembly. This assembly is fixed by a hook.
3. Disconnect the connections from the fan motor.

7.3.7.3 Assembly Procedures

1. Assemble the fan motor and paper exit frame assembly.
2. Reassemble in reverse order of disassembly.

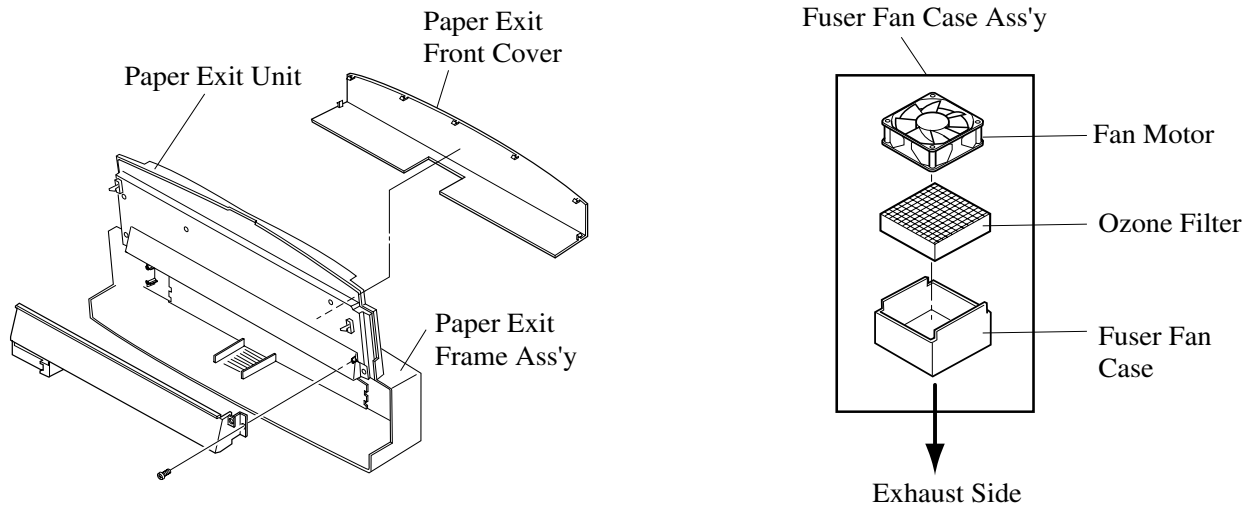

Fig. 7-38

CAUTION:

When installing the fan motor, make sure the label of the motor faces towards the exhaust side.

7.3.8 Ozone Fan (OZ FAN) / Ozone Duct Assembly

7.3.8.1 Tools

Phillips Screwdrivers #1 and #2

7.3.8.2 Disassembly Procedures

(see Fig. 7-39 and Fig. 7-40)

1. Remove the right side cover (see section 7.1.2).
2. Remove the right base cover (see section 7.1.10).
3. Remove three fixing screws (ST3x6) from the stay (R).
4. Remove the stay (R) from the frame.
5. Remove the ozone fan duct.
6. Disconnect the ozone fan connector (DCN5) from the IOS2 P.W.B.
7. Remove one fixing screw (ST3x6) from the ozone fan case.
8. Remove the ozone fan case.
9. Open the ozone fan case, and remove the ozone fan motor.

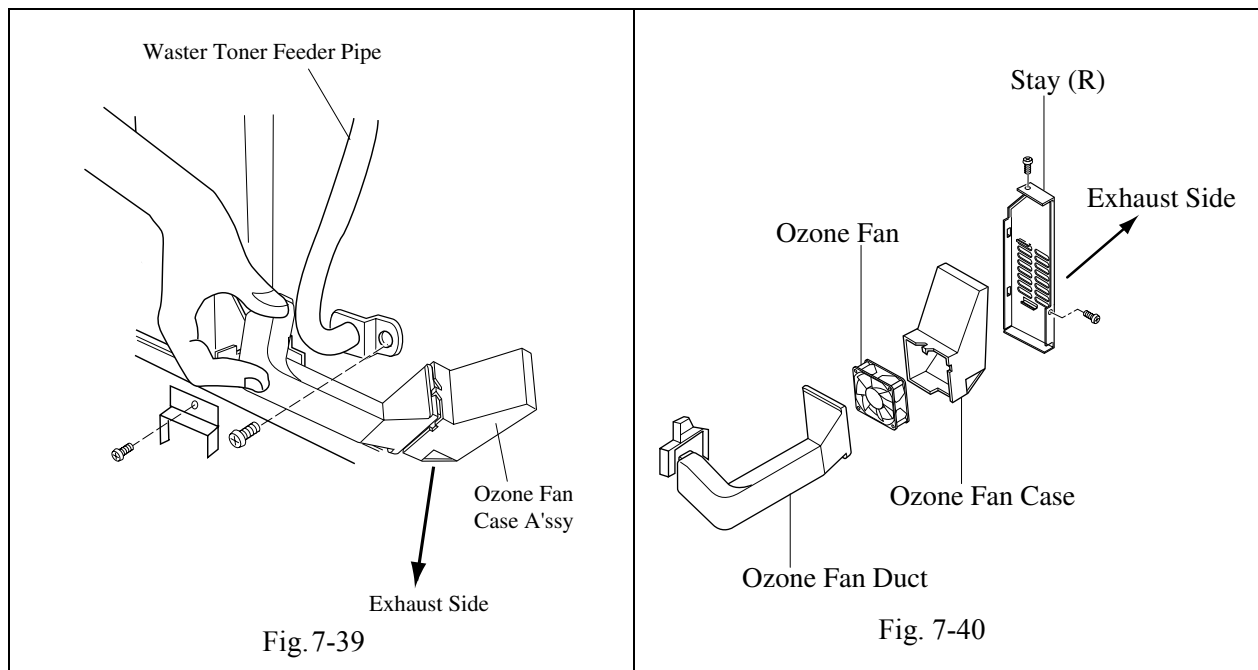

7.3.8.3 Assembly Procedures

1. Reassemble in reverse order of disassembly.

7.4 Replacement of Clutches
Layout of Clutch

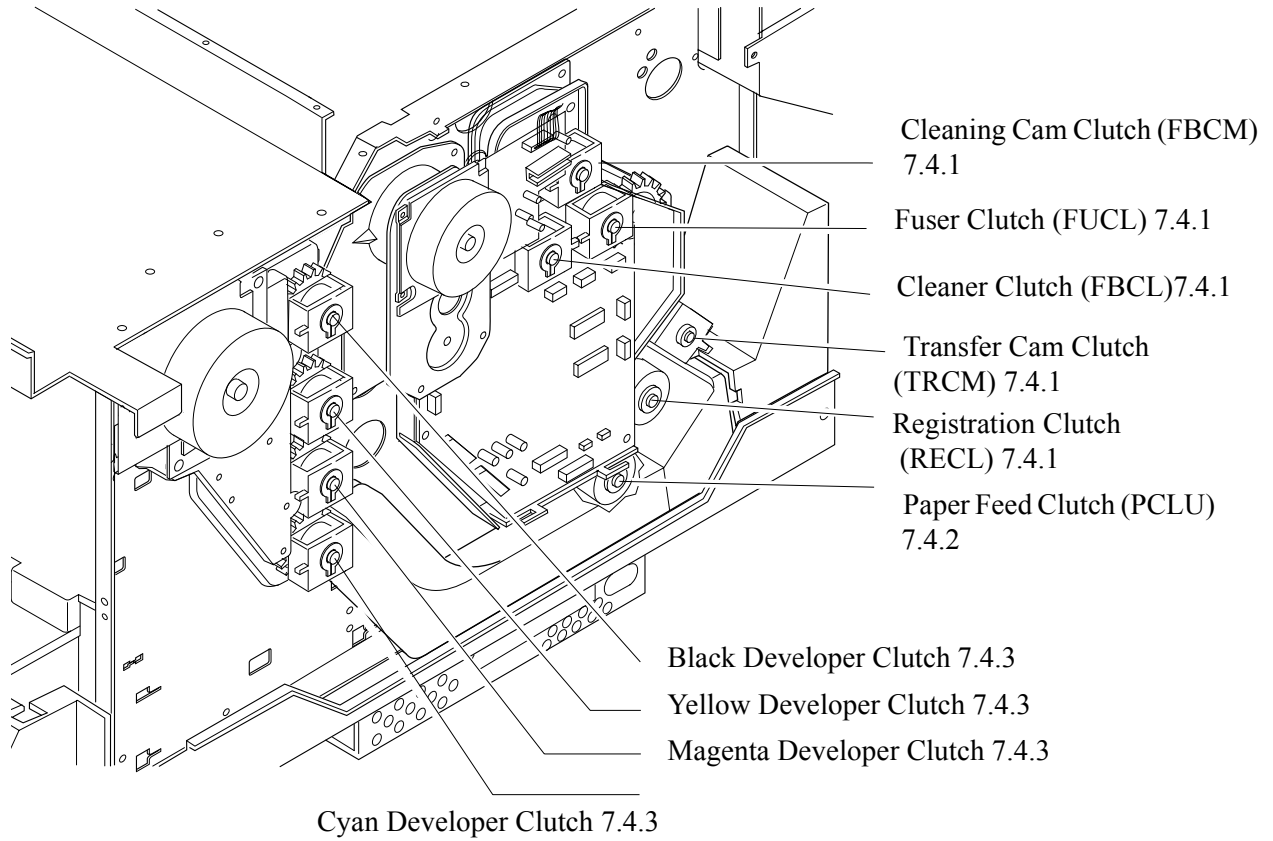

Fig. 7-41

7.4.1 Clutches (FUCL, FBCL, RECL, FBCM, TRCM)

7.4.1.1 Tools

Phillips Screwdrivers #1 and #2
Small Slotted Screwdriver #1

7.4.1.2 Disassembly Procedures

(see Fig. 7-42)

1. Remove the right side cover.
2. Remove the harness connector of the appropriate clutch from the IOD2.
3. Remove the washer of the appropriate clutch from the shaft.
4. Pull out the clutch from the shaft.

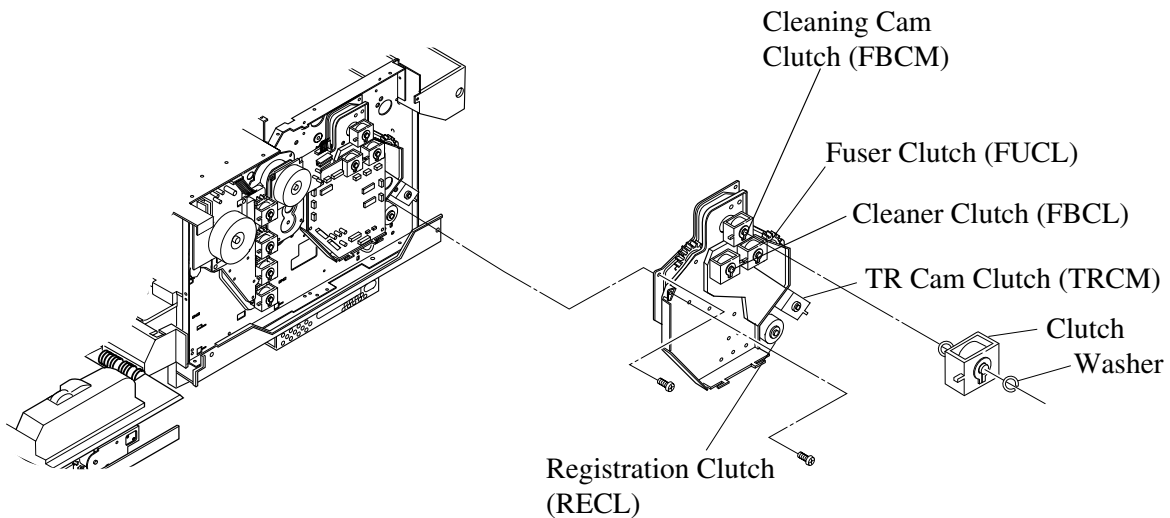

Fig. 7-42

7.4.1.3 Assembly Procedures

1. Install new clutches at the appropriate locations.
2. Reassemble in reverse order of disassembly.

7.4.2 Paper Feeding Clutch (PCLC)

7.4.2.1 Tools

Phillips Screwdrivers #1 and #2
Slotted Screwdriver #1

7.4.2.2 Disassembly Procedures

(see Fig. 7-43)

1. Remove the ozone duct assembly (see section 7.3.8).
2. Remove the main gear unit (see section 7.3.2).
3. Remove the washer of the paper feeder clutch from the shaft.
4. Pull out the paper feeding clutch from the shaft.

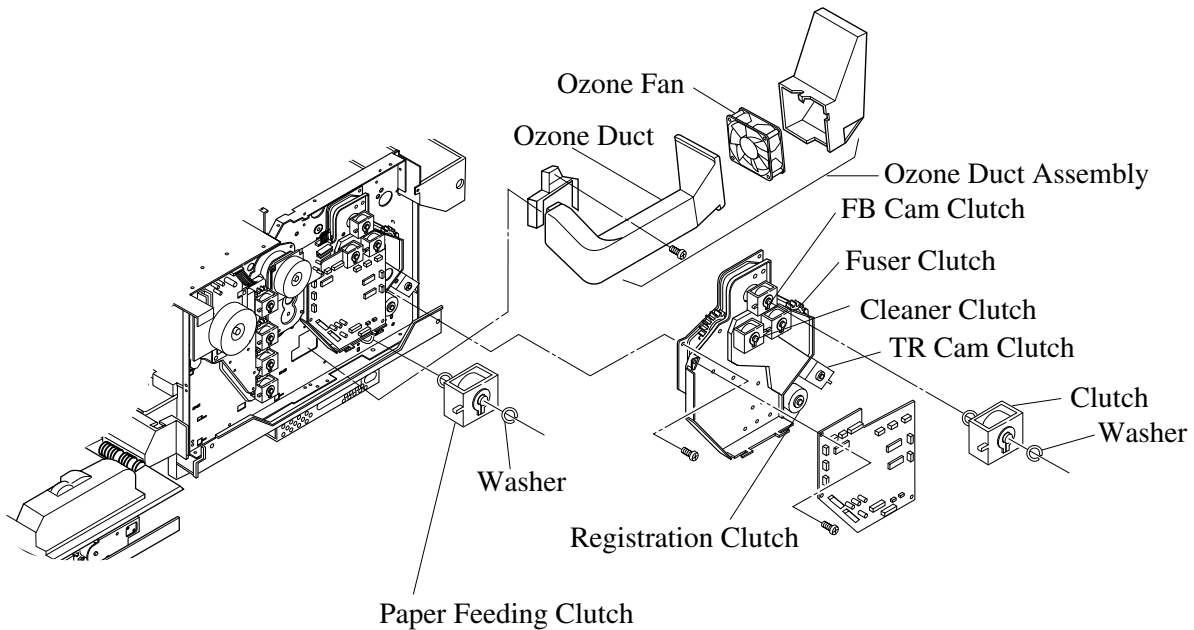

Fig. 7-43

7.4.2.3 Assembly Procedures

1. Install the new paper feeding clutch onto the shaft.
2. Install the washer onto the shaft.
3. Reassemble in reverse order of disassembly.

7.4.3 Developer Clutch (DVCL)

7.4.3.1 Tools

Phillips Screwdrivers #1 and #2
Slotted Screwdriver #1

7.4.3.2 Disassembly Procedures

(see Fig. 7-44)

1. Remove the right side cover.
2. Disconnect the harness connector of the appropriate clutch from IOD2.
3. Remove the washer from the shaft of the appropriate clutch.
4. Pull out the clutch from the shaft.

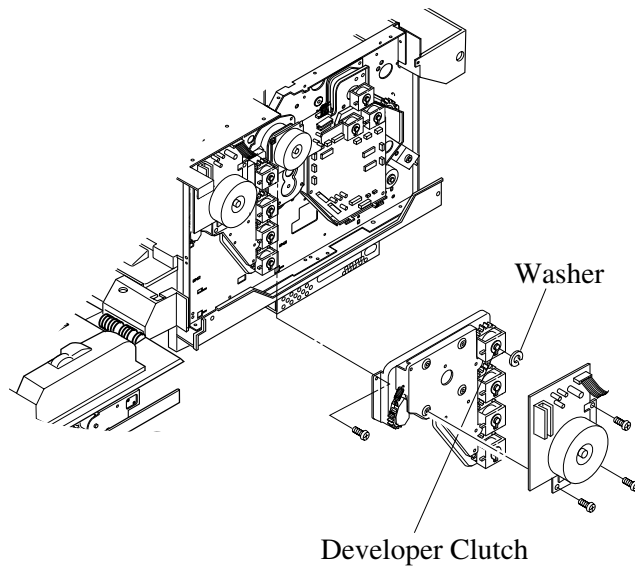

Fig. 7-44

7.4.3.3 Assembly Procedures

1. Prepare a new clutch. This clutch is common for all four colors.
2. Install the new clutch to the appropriate location.
3. Install the washer onto the shaft.
4. Reassemble in reverse order of disassembly.

7.5 Replacement of Switches and Sensors
 Layout of Switches and Sensors

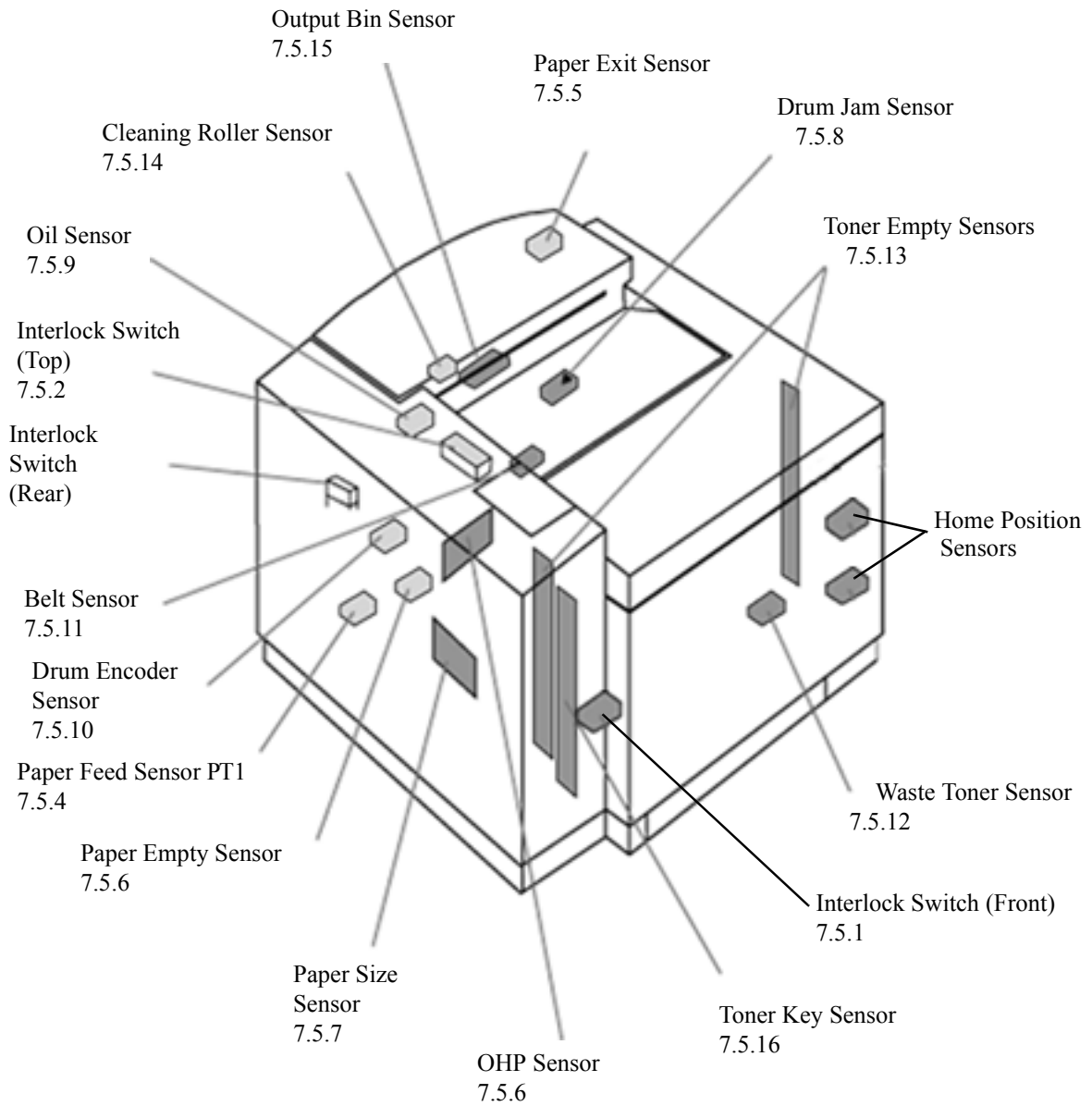

Fig. 7-45

7.5.1 Interlock Switch (Front Door)

7.5.1.1 Tools

Phillips Screwdrivers #1 and #2

7.5.1.2 Disassembly Procedures

(see Fig. 7-46)

1. Remove the controller case A assembly (see section 7.2.5.2[13]).
2. Disconnect the connector from the switch.
3. Remove the switch from the switch base.

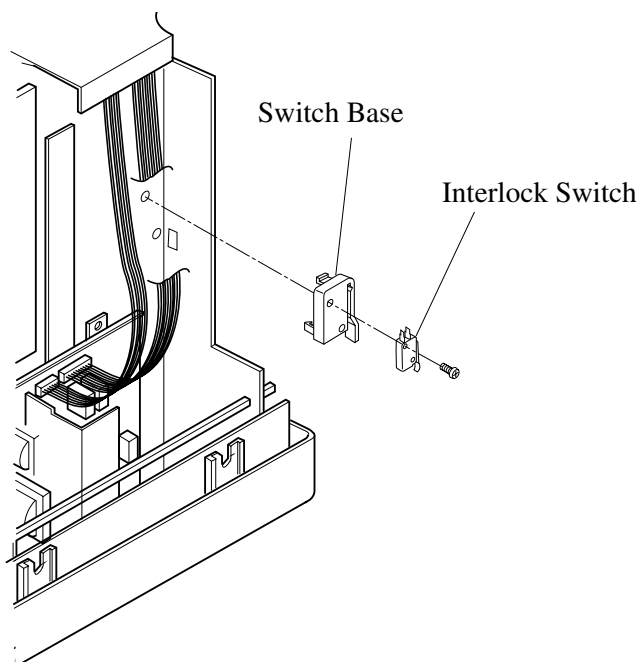

Fig. 7-46

7.5.1.3 Assembly Procedures

1. Install the new switch onto the switch base.
2. Reassemble in reverse order of disassembly.

7.5.2 Interlock Switch (Paper Exit Cover)

7.5.2.1 Tools

Phillips Screwdrivers #1 and #2

7.5.2.2 Disassembly Procedures (see Fig. 7-47)

1. Remove the controller fan (see section 7.3.6).
2. Remove the switch from the controller fan case.
3. Remove the actuator lever.

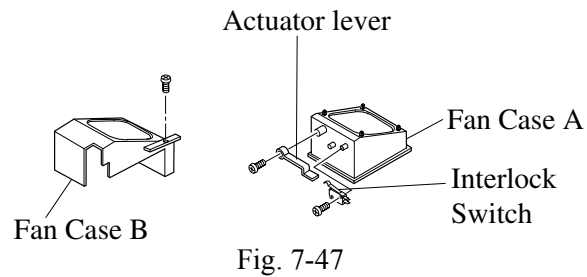

7.5.2.3 Assembly Procedures

1. Assemble the new switch onto the controller case.
2. Install the actuator lever.
3. Reassemble in reverse order of disassembly.

7.5.3 Interlock Switch (Left Access Plate area)

7.5.3.1 Tools

#1 Phillips Screwdriver

7.5.3.2 Disassembly Procedures

(see Fig. 7-48)

1. Remove the left side cover (see section 7.1.3).
2. Remove the high voltage power supply (see section 7.2.6).
3. Remove the transfer drum (see section 7.6.3).
4. Remove two set screws (ST3x6) from the transfer electrode base.
5. Remove the transfer electrode base from the frame.
6. Disconnect all the harness connectors from the interlock switch.
7. Remove the interlock switch from the transfer electrode base.

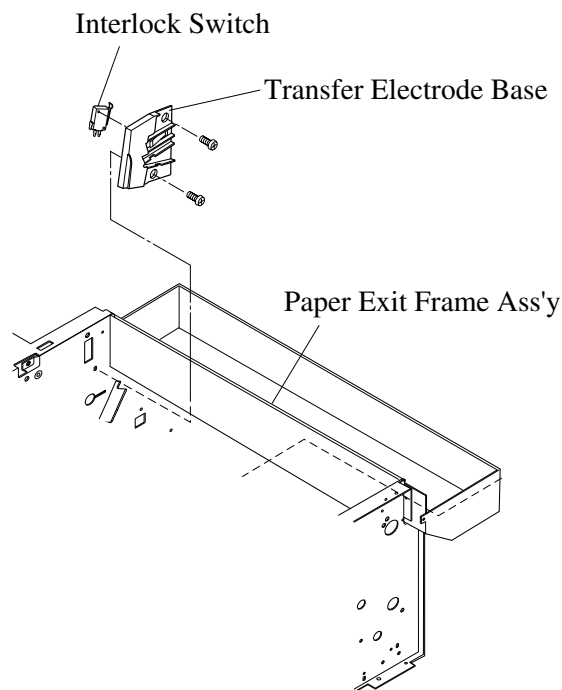

Fig. 7-48

7.5.3.3 Assembly Procedures

1. Install a new interlock switch to the transfer electrode base.
2. Reassemble in reverse order of disassembly.

CAUTION:

The interlock switch is important for safety. After installation, verify that the switch operates normally.

7.5.4 Paper Sensor (Paper Feeding Sensor PT1)

7.5.4.1 Tool

#1 Phillips Screwdriver

7.5.4.2 Disassembly Procedures

(see Fig. 7-49)

1. Remove the transfer unit (see section 7.6.1).
2. Remove the upper-left paper guide assembly by removing two set screws (ST3x6).
3. Unlock the paper feeding sensor from the rear side of the hole through which the upper-left paper guide has been removed.
4. Disconnect all the connectors from the paper feeding sensor.
5. Remove the paper feeding sensor from the feeder stay.

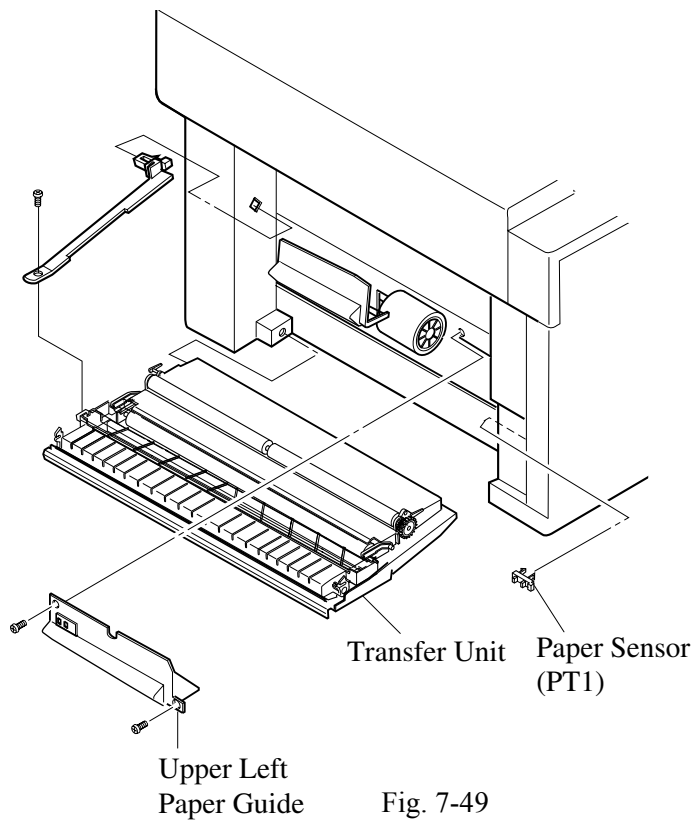

7.5.4.3 Assembly Procedures

1. Install a new paper feeding sensor to the feeder stay.
2. Connect the harness connectors to the paper feeding sensor.
3. Reassemble in reverse order of disassembly.

7.5.5 Paper Sensor (Paper Exit Sensor PT2)

7.5.5.1 Tool

#2 Phillips Screwdriver

7.5.5.2 Disassembly Procedures

(see Fig. 7-50)

1. Open the paper exit cover.
2. Remove the paper exit unit (see section 7.6.6).
3. Remove the paper exit cover (see section 7.1.6).
4. Remove two set screws (ST3x6) from the sensor base.
5. Remove the sensor base from paper exit frame.
6. Disconnect the harness connector from the paper exit sensor (PT2).
7. Remove the paper sensor from the sensor base.

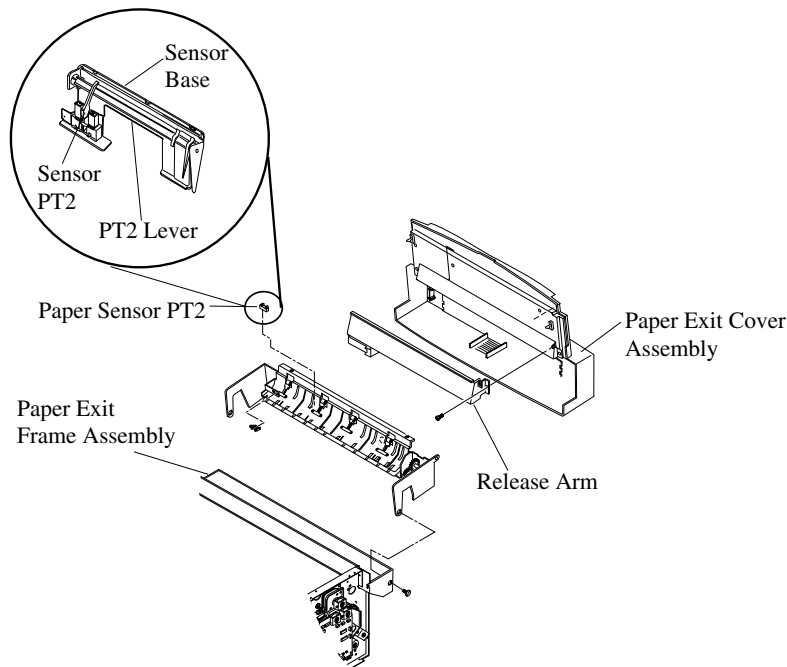

Fig. 7-50

7.5.5.3 Assembly Procedures

1. Install a new paper sensor (PT2) onto the paper guide.
2. Connect the harness connector to the paper sensor.
3. Reassemble in reverse order of disassembly.

7.5.6 Paper Empty Sensor (PE) / OHP Sensor (OHP)

7.5.6.1 Tool

#1 Phillips Screwdriver

7.5.6.2 Disassembly Procedures

(Fig. 7-51)

1. Remove the transfer unit (see section 7.6.1).
2. Remove two set screws (ST3x6) from the left paper guide.
3. Remove the left paper guide.
4. Remove two set screws (ST3x6) from the upper-left paper guide.
5. Remove the connector from the sensor.
6. Remove the upper-left paper guide.
7. Remove the paper empty sensor (PE) from the upper-left paper guide, or remove two set screws (BT3x8) from the OHP sensor (OHP) to remove it from the upper-left paper guide.
8. Remove the OHP sensor (OHP).

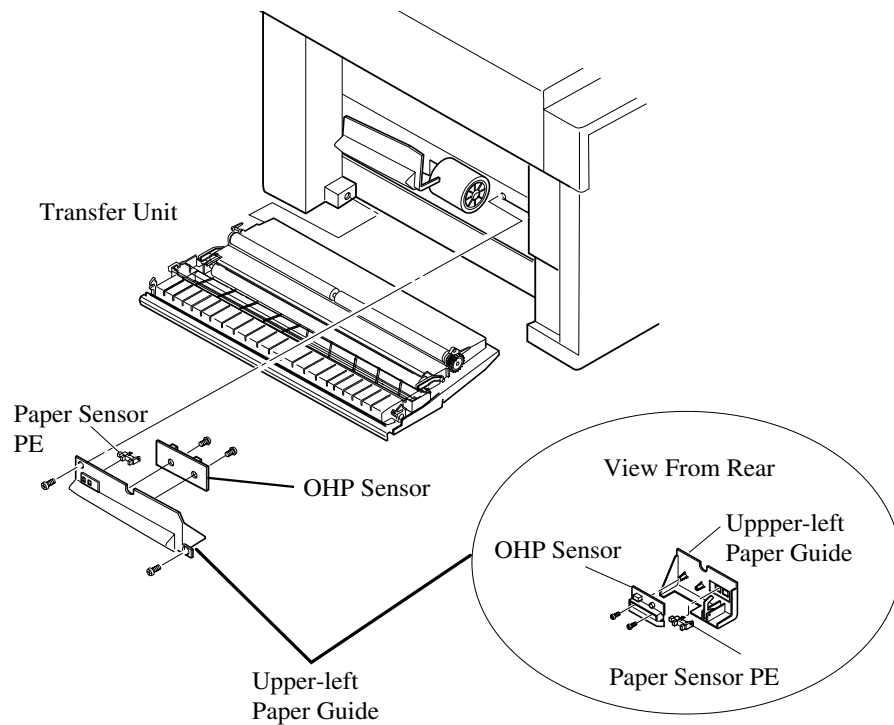

Fig. 7-51

7.5.6.3 Assembly Procedures

1. Install a new paper empty sensor (PE) or a new OHP sensor (OHP) onto the upper-left paper guide.
2. Reassemble in reverse order of disassembly.

7.5.7 Paper Size Sensor PSU

7.5.7.1 Tool

#1 Phillips Screwdriver

7.5.7.2 Disassembly Procedures

(see Fig. 7-52)

1. Remove the transfer unit (see section 7.6.1).
2. Remove the left paper guide by removing two set screws (ST3X6) (see section 7.6.1).
3. Remove two set screws (ST3x6) from the paper size sensor.
4. Disconnect all the connectors from the paper size sensor.
5. Remove the paper size sensor.

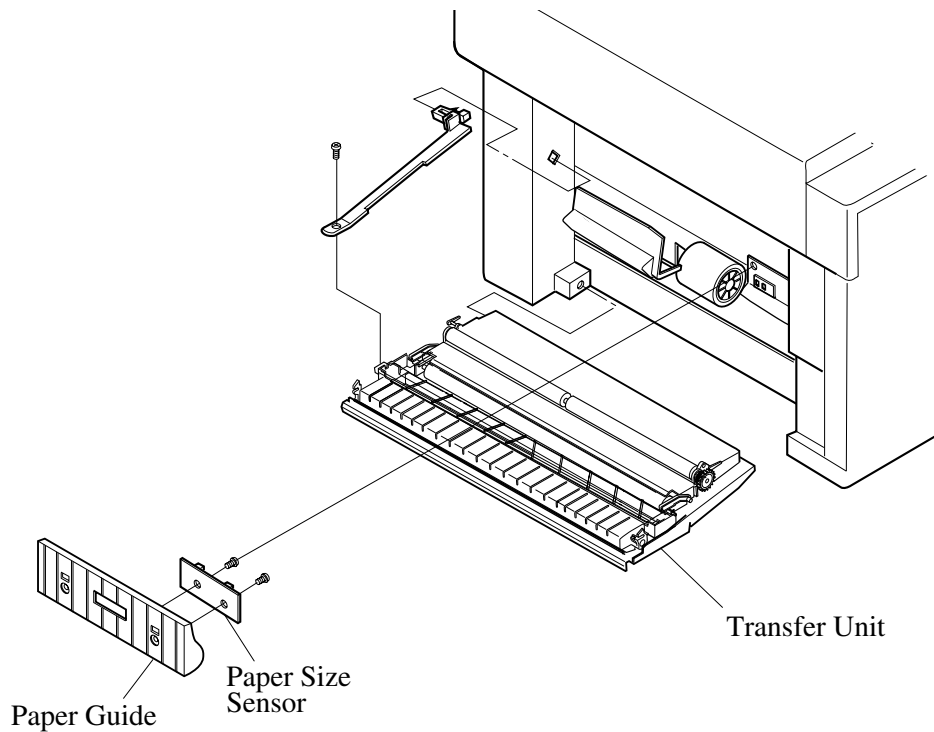

Fig. 7-52

7.5.7.3 Assembly Procedures

1. Reassemble in reverse order of disassembly.

7.5.8 Drum Jam Sensor DPJ

7.5.8.1 Tools

Phillips Screwdrivers #1 and #2

7.5.8.2 Disassembly Procedures

(see Fig. 7-53)

1. Remove the fuser (see section 7.7).
2. Remove the belt cartridge (see section 3.3.2).
3. Remove the upper-left side cover (see section 7.1.1).
4. Remove the top cover (see section 7.1.5).
5. Remove the drum cleaner (see section 7.1.12).
6. Remove the transfer drum (see section 7.6.3).
7. Remove the fuser cover (located under fuser).
8. Disconnect all the connectors from the drum jam sensor.
9. Remove the drum jam sensor from the stay B.

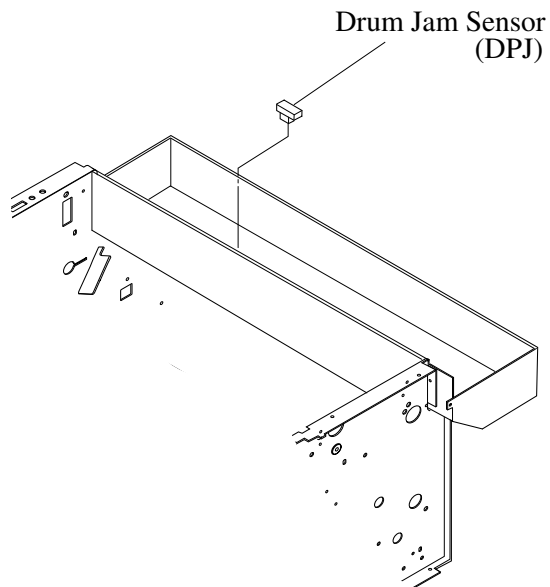

Fig. 7-53

7.5.8.3 Assembly Procedures

1. Reassemble in reverse order of disassembly.

7.5.9 Oil Sensor (OIL)

7.5.9.1 Tools

Phillips Screwdrivers #1 and #2

7.5.9.2 Disassembly Procedures

(see Fig. 7-54)

1. Remove the fuser (see section 7.7).
2. Remove the fusing cover (located under fuser).
3. Disconnect the oil sensor connector.
4. Remove two set screws (ST3x6) from the oil sensor.
5. Remove the oil sensor.

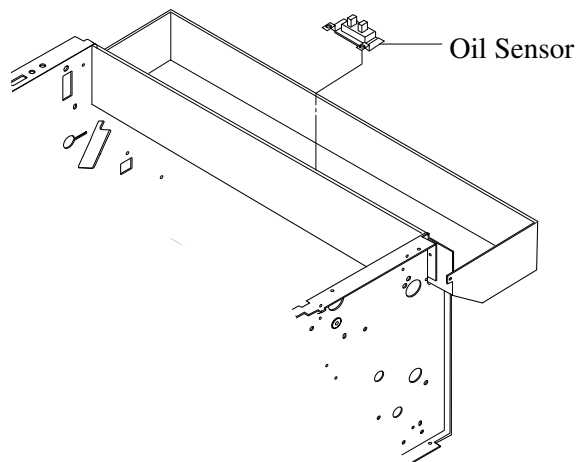

Fig. 7-54

7.5.9.3 Assembly Procedures

1. Install a new oil sensor.
2. Reassemble in reverse order of disassembly.

7.5.10 Drum Encoder Sensor (EN)

7.5.10.1 Tools

Phillips Screwdrivers #1 and #2

7.5.10.2 Disassembly Procedures

(see Fig. 7-55)

1. Remove the toner cartridges (see section 3.3.3).
2. Remove the belt cartridge (see section 3.3.2).
3. Remove the drum cleaner (see section 7.1.12).
4. Remove the fuser (see section 7.7).
5. Remove the left side cover (see section 7.1.3).
6. Remove the top cover (see section 7.1.5).
7. Remove the transfer drum (see section 7.6.3).
8. Remove the high voltage power supply (see section 7.2.6).
9. Remove the sensor holder assembly from the frame (L).
10. Disconnect the connectors connected with the encoder sensor.
11. Remove the encoder sensor from the sensor holder.

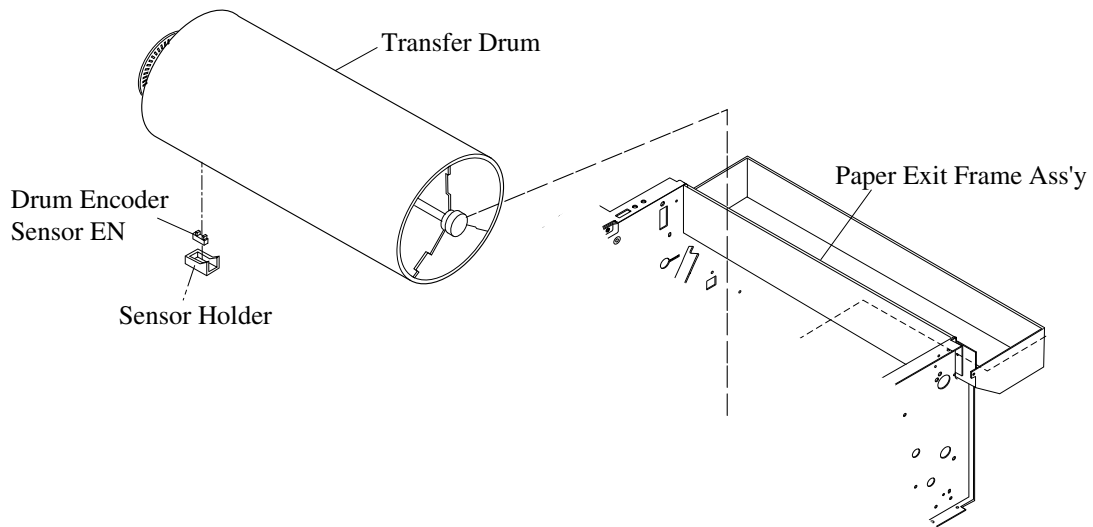

Fig. 7-55

7.5.10.3 Assembly Procedures

1. Install a new drum encoder sensor onto the sensor holder.
2. Reassemble in reverse order of disassembly.

7.5.11 Belt Marker Sensor (PBS)

7.5.11.1 Tools

Phillips Screwdrivers #1 and #2

7.5.11.2 Disassembly Procedures

(see Fig. 7-56)

1. Remove the toner cartridges (see section 3.3.3).
2. Remove the belt cartridge (see section 3.3.2).
3. Remove the top cover (see section 7.1.5).
4. Remove the upper shield cover.
5. Remove one fixing screw (ST3x6) from the PBS Base.
6. Disconnect the connector from the belt marker sensor.
7. Remove the belt marker sensor from the PBS Base.

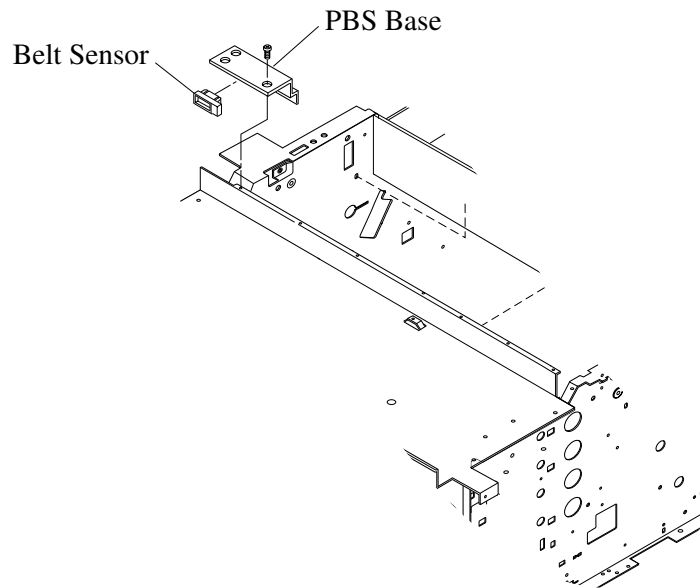

Fig. 7-56

7.5.11.3 Assembly Procedures

1. Assemble the new belt marker sensor to the PBS Base.
2. Connect the harness connector with the belt marker sensor.
3. Reassemble in reverse order of disassembly.

7.5.12 Waste Toner Sensor (WTS)

7.5.12.1 Tools

Phillips Screwdrivers #1 and #2

7.5.12.2 Disassembly Procedures

(see Fig. 7-57)

1. Remove the right side cover (see section 7.1.2).
2. Remove the right base cover (see section 7.1.10).
3. Remove the front stay (R) (see section 7.3.4.2[5]).
4. Remove the set screw of the bottle holder.
5. Remove the bottle holder (see section 7.3.4.2[6]).

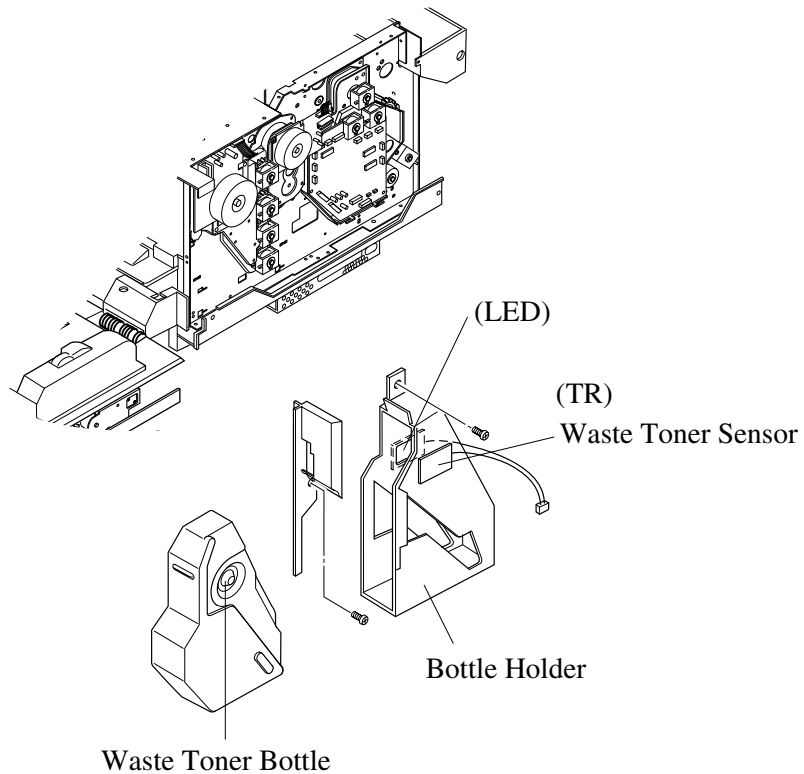

Fig. 7-57

7.5.12.3 Assembly Procedures

1. Prepare a new bottle holder.
2. Reassemble in reverse order of disassembly.

7.5.13 Toner Sensor Assemblies (TPD and TTR)

7.5.13.1 Tools

Phillips Screwdrivers #1 and #2

7.5.13.2 Disassembly Procedures

(see Fig. 7-58)

7.5.13.2.1 TPD

1. Remove the right side cover (see section 7.1.2).
2. Remove the developer drive unit (see section 7.3.3 and see section 7.3.4).
3. Remove two set screws (ST3x6) from the toner sensor P.W.B.
4. Disconnect the connector from the TPD toner sensor P.W.B.

7.5.13.2.2 TTR

1. Remove the left side cover (see section 7.1.3).
2. Remove the high voltage power supply (HVPS) (see section 7.2.6).
3. Remove the low voltage power supply (LVPS) (see section 7.2.5).
4. Remove three set screws (ST3x6) of toner sensor P.W.B.
5. Disconnect the connector from the TTR toner sensor P.W.B.
6. Remove the toner sensor P.W.B.

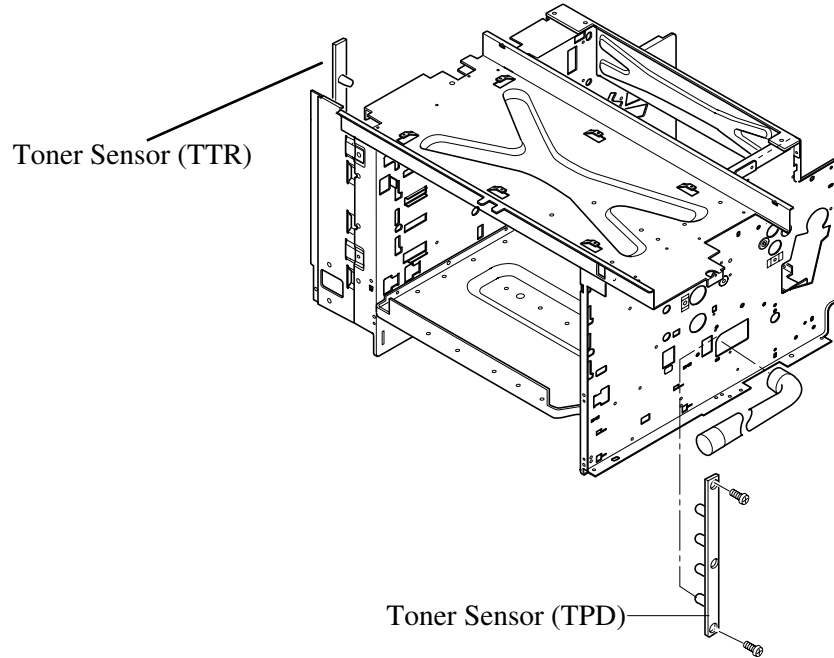

Fig 7-58

7.5.13.3 Assembly Procedures

7.5.13.3.1 TPD

1. Connect the connector to the new TPD toner sensor P.W.B.
2. Install the toner sensor P.W.B. to the engine frame (R).
3. Reassemble in reverse order of disassembly.

7.5.13.3.2 TTR

1. Connect the connector to the new TTR toner sensor P.W.B.
2. Install the toner sensor P.W.B. to the engine frame (L).
3. Reassemble in reverse order of disassembly.

7.5.14 Cleaning Roller Sensor CRS

7.5.14.1 Tool

#1 Phillips Screwdriver

7.5.14.2 Disassembly Procedures

(see Fig. 7-59)

1. Open the paper exit cover.
2. Remove the paper exit unit (see section 7.6.6).
3. Remove the harness cover.
4. Remove one set screw (ST3x6) from the sensor base.
5. Disconnect the connectors from the cleaning roller sensor.
6. Remove the cleaning roller sensor.
 - a. Put your finger in the rear side of installation base, and then, unhook the base.
 - b. Remove the sensor.

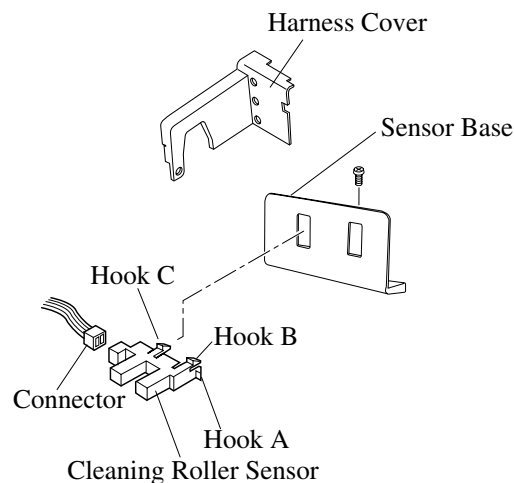

Fig. 7-59

CAUTION:

When installing the connector onto the cleaning roller sensor, do not apply any excessive force to the sensor connector (Print P.W.B.).

7.5.14.3 Assembly Procedures

1. Install the sensor onto the base.
2. Connect the harness connectors to the cleaning roller sensor.
3. Confirm that hooks a, b, and c are hooked firmly onto the sensor base.
4. Reassemble in reverse order of disassembly.

7.5.15 Paper Full Sensor PFUS

7.5.15.1 Tools

Phillips Screwdrivers #1 and #2

7.5.15.2 Disassembly Procedures

(see Fig. 7-60)

1. Remove the paper exit unit (see section 7.6.6).
2. Remove the harness cover.
3. Remove the paper exit unit cover (see section 7.1.6).
4. Disconnect the harness connector connected from the paper exit sensor.
5. Remove the paper full sensor. Unhook the installation base, and remove the switch.

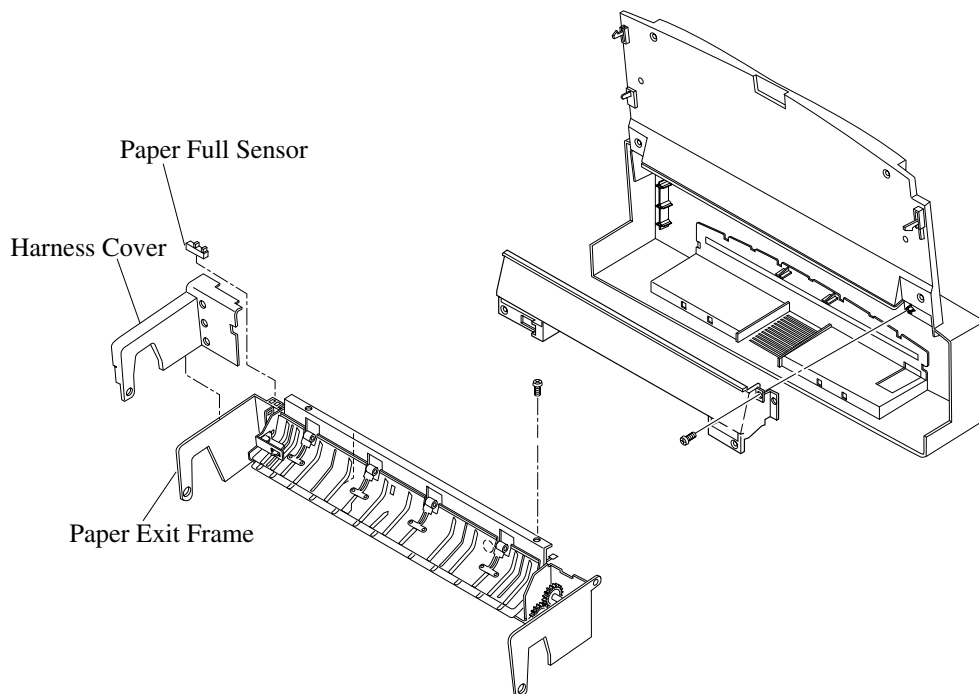

Fig. 7-60

7.5.15.3 Assembly Procedures

6. Reassemble in reverse order of disassembly.

7.5.16 Toner Key Sensor TNK

7.5.16.1 Tools

Phillips Screwdrivers #1 and #2

7.5.16.2 Disassembly Procedures

(see Fig. 7-61)

1. Remove the left-upper side cover (see section 7.1.1).
2. Remove the left side cover (see section 7.1.3).
3. Remove the shield case A assembly (see section 7.2.5.2[13]).
4. Remove the upper shield cover.
5. Disconnect the connector from DCN5 of IOD1.
6. Remove four set screws (ST3x6) from the toner key sensor.
7. Remove the toner key sensor.

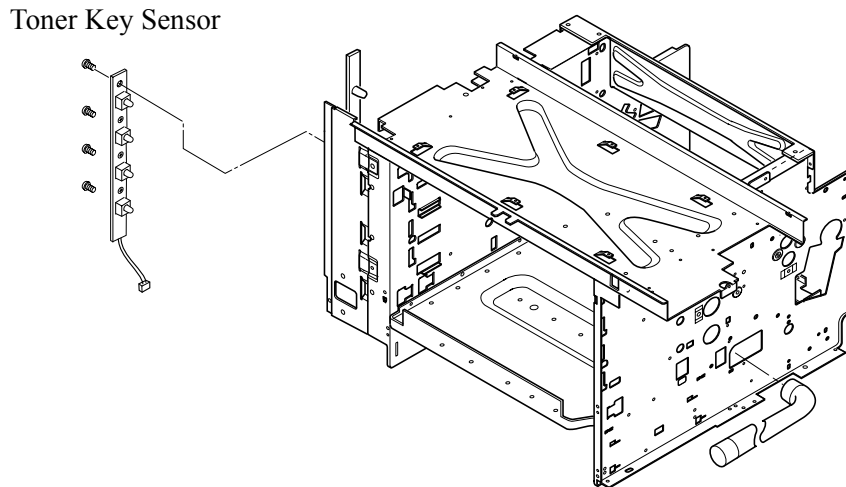

Fig. 7-61

7.5.16.3 Assembly Procedures

1. Install the new toner key sensor.
2. Reassemble in reverse order of disassembly.

7.6 Replacement of Rollers, Drums, and Other Components

7.6.1 Transfer Unit

7.6.1.1 Tool

#1 Phillips Screwdriver

7.6.1.2 Disassembly Procedures

(see Fig. 7-62)

1. Remove one fixing screw (BT4x10) from the transfer unit's retainer band.
2. Remove the transfer unit's shaft from the installation hole of the frame, and remove the transfer unit (see section 7.6.1).
 - a. Holding the transfer unit horizontally, first remove the right side of the shaft from the hole.

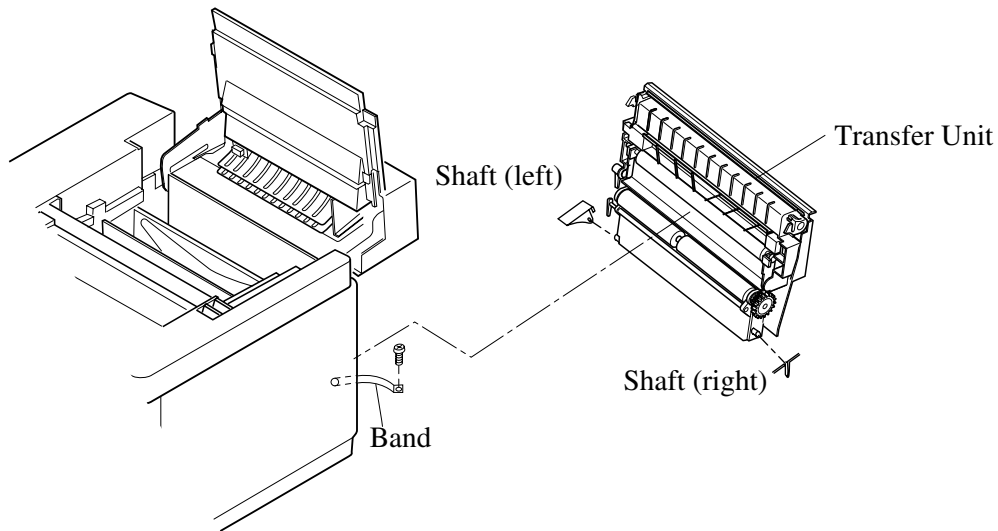

Fig. 7-62

7.6.1.3 Assembly Procedures

1. Align the new transfer unit to the installation hole of base, and press it in.
 - a. Put the transfer unit shaft in the hole on the left side (viewed from the front).
 - b. Sliding the transfer unit towards the left, put the right side of the shaft into the hole.

7.6.2 Registration Roller

7.6.2.1 Tools

#1 Phillips Screwdriver
Slotted Screwdriver #1

7.6.2.2 Disassembly Procedures

(see Fig. 7-63)

1. Open the transfer unit.
2. Remove the fixing washer of the roller at both ends.
3. Remove the gear from the shaft.
4. Remove the bearing from each end.
5. Remove the registration roller from the transfer unit frame.

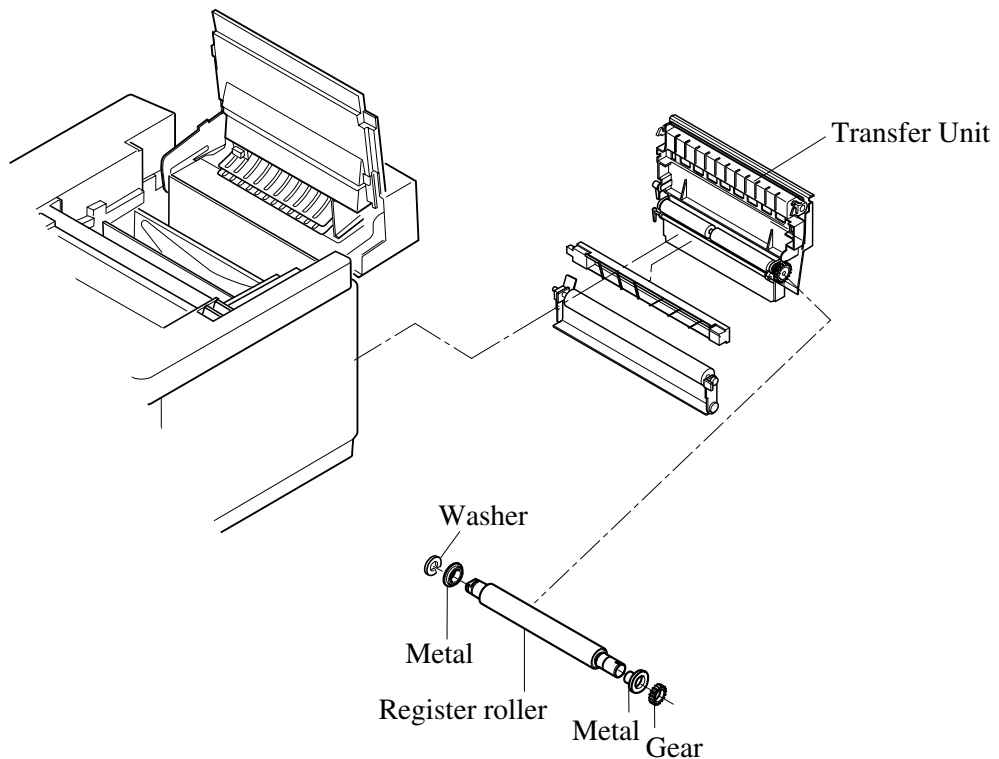

Fig. 7-63

7.6.2.3 Assembly Procedures

1. Install the new registration roller into the hole of the transfer unit frame.
2. Install a bearing on each end.
3. Install the gear on the right side.
4. Install the fixing washer and the bearing.

7.6.3 Transfer Drum

7.6.3.1 Tools

Phillips Screwdrivers #1 and #2

7.6.3.2 Disassembly Procedures

(see Fig. 7-64)

1. Remove the toner cartridge.
2. Remove the belt cartridge.
3. Remove the fuser.
4. Remove the cleaner cover.
5. Remove the drum cleaner.
6. Open the transfer unit.
7. Remove the top cover (see section 7.1.5).
8. Remove two set screws (ST3x6) from stay 'A'.
9. Remove the stay 'A' assembly.
10. Wrap the transfer drum with paper so that it will not be scratched.
11. Pull the transfer drum from the top side, and remove the transfer drum from the shaft support.
12. Remove the transfer drum from the top.

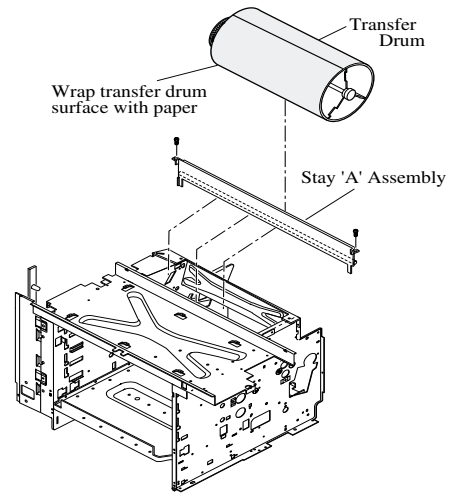

Fig.7-64

7.6.3.3 Assembly Procedures

1. Install the new transfer drum into the printer from the top.
2. Position the transfer drum's shaft so that it meets the drum shaft support.
3. Push the transfer drum into the shaft support.
4. Install the stay 'A' assembly.
5. Reassemble in reverse order of disassembly.

CAUTION:

Do not touch the transfer drum surface with your bare hands. Do not scratch the surface of the drum.

7.6.4 Paper Feed Roller / Separator Pad

7.6.4.1 Tool

#1 Phillips Screwdriver

7.6.4.2 Disassembly Procedures

(see Fig. 7-65)

1. Remove the paper feeding cassette.
2. Remove the transfer unit (see section 7.6.1).
3. Remove two set screws (ST3x6) from the left paper guide.
4. Remove the left paper guide.
5. Remove two set screws (ST3x6) from the upper-left paper guide.
6. Remove the upper-left paper guide.
7. Disconnect all the harness connectors from the OHP sensor and paper sensor.
8. Sliding the paper feeding roller to the right side, remove it from the shaft.
9. Pull up the separator pad and remove it.

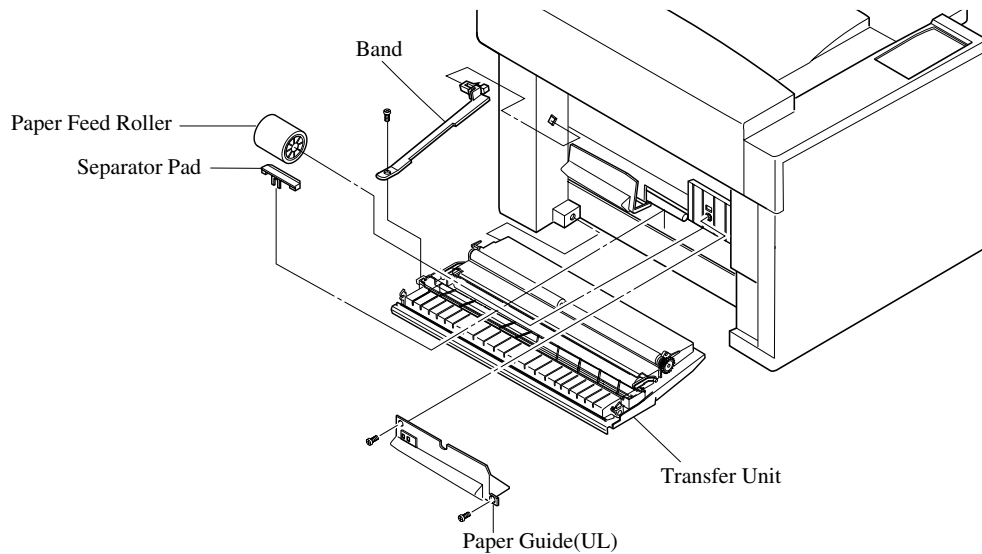

Fig. 7-65

CAUTION:

Do not touch the surface of the new paper feed roller and separator pad.

7.6.4.3 Assembly Procedures

1. Reassemble in reverse order of disassembly.

7.6.5 Front Cover Unit

7.6.5.1 Tools

Phillips Screwdrivers #1 and #2

7.6.5.2 Disassembly Procedures

(see Fig. 7-66)

1. Open the front cover.
2. Remove the front cover (see section 7.1.13).
3. Disconnect four harness connectors from the front cover unit.
4. Remove one fixing screw (M3x6) from front cover unit hinge support.
5. Remove the hinge support from the frame.
6. Remove four fixing screws (M4x6) from the front cover unit supports (2 each at left and right side).
7. Remove the front cover unit.

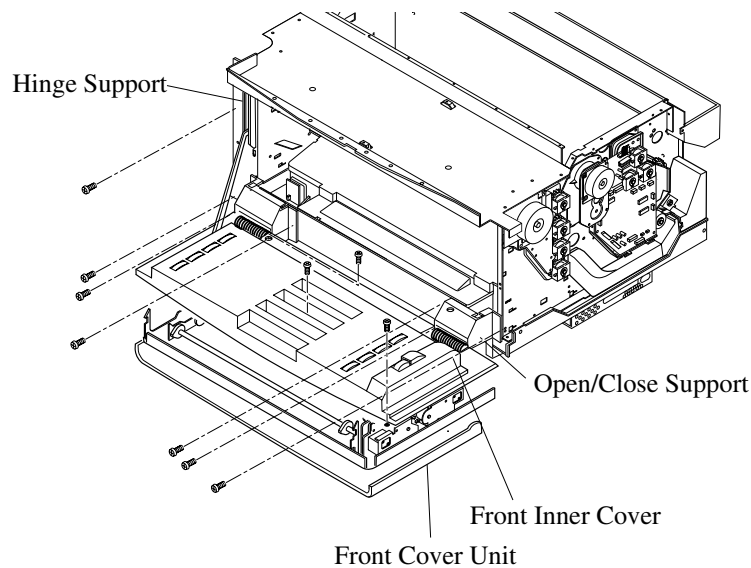

Fig. 7-66

7.6.5.3 Assembly Procedures

1. Attach the front cover unit support into the hole of engine side.
2. Secure the support from the rear side with the fixing screws (2 locations each at left and right side) with the front door closed.
3. Open the front door, and install the hinge support to the frame.
4. Tighten the remaining screws (2 locations at left and right sides) to the front cover unit supports.
5. Reassemble in reverse order of disassembly.

7.6.6 Paper Exit Unit/Paper Exit Roller

7.6.6.1 Tools

Phillips Screwdrivers #1 and #2

7.6.6.2 Disassembly Procedures

(see Fig. 7-67)

1. Remove the left and right side covers (see section 7.1.3 and section 7.1.2).
2. Disconnect the harness connector from the paper exit unit.
3. Remove two support pins (left and right sides) of paper exit unit.
4. Remove the paper exit unit.
5. Remove the paper exit cover (see section 7.1.6).
6. Remove the fixing washers at both ends.
7. Remove the bearings from both ends.
8. Remove the paper exit roller from the frame.

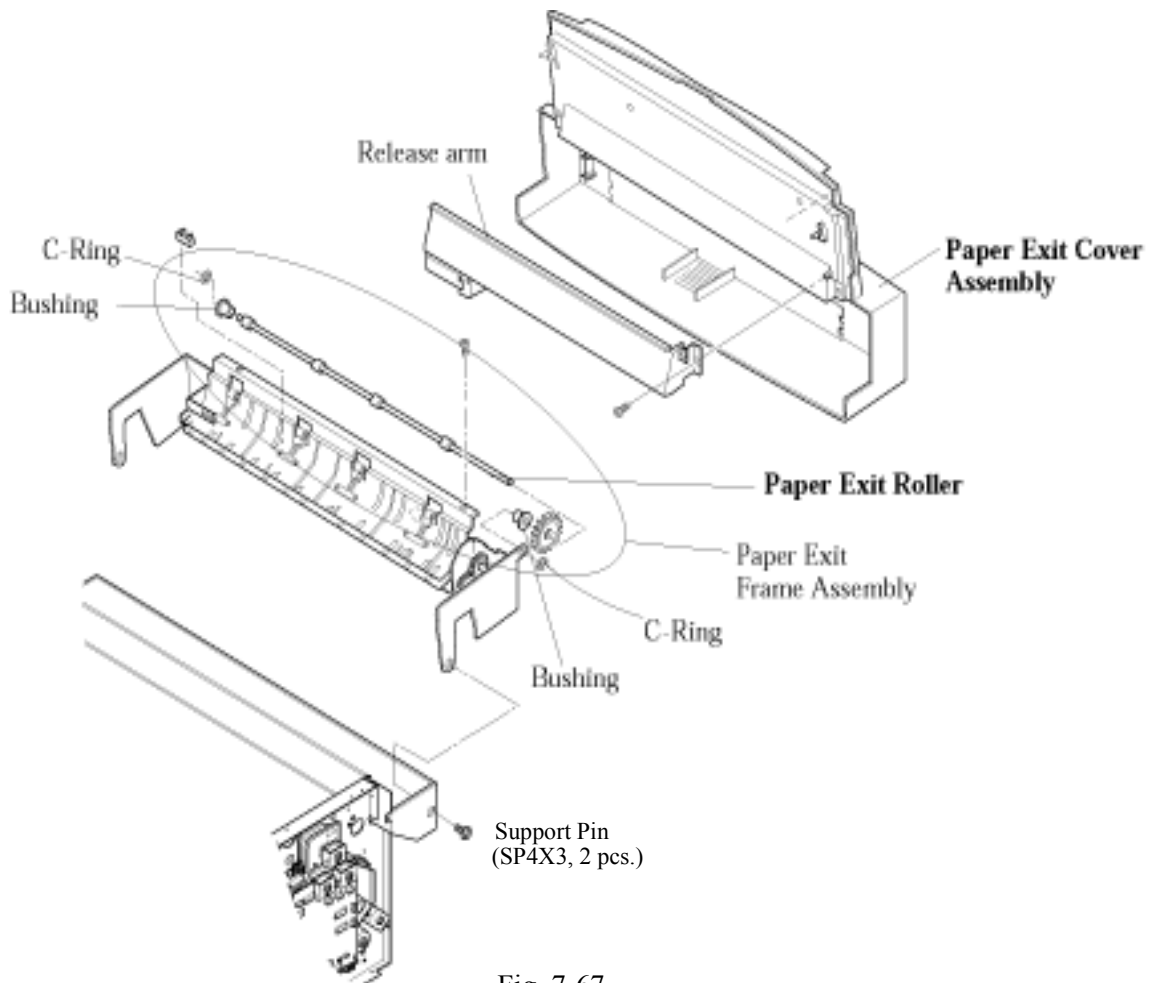

Fig. 7-67

7.6.6.3 Assembly Procedures

1. Prepare new paper exit roller.
2. Install the paper exit roller into the installation hole of the paper exit frame.
3. Install the left and right bearings on the paper exit roller shaft.
4. Mount the bearings onto the frame.
5. Install the washers on the left and right side of the paper exit roller.
6. Reassemble in reverse order of disassembly.

7.6.7 Discharger Brush

7.6.7.1 Tools

Phillips Screwdrivers #1 and #2

7.6.7.2 Disassembly Procedures

(see Fig. 7-68)

1. Open the paper exit unit.
2. Remove the paper exit front cover (see section 7.1.6).
3. Remove the paper exit cover (see section 7.6.6).
4. Remove two fixing screws (BT4x8) from the discharger brush.
5. Remove the discharger brush.

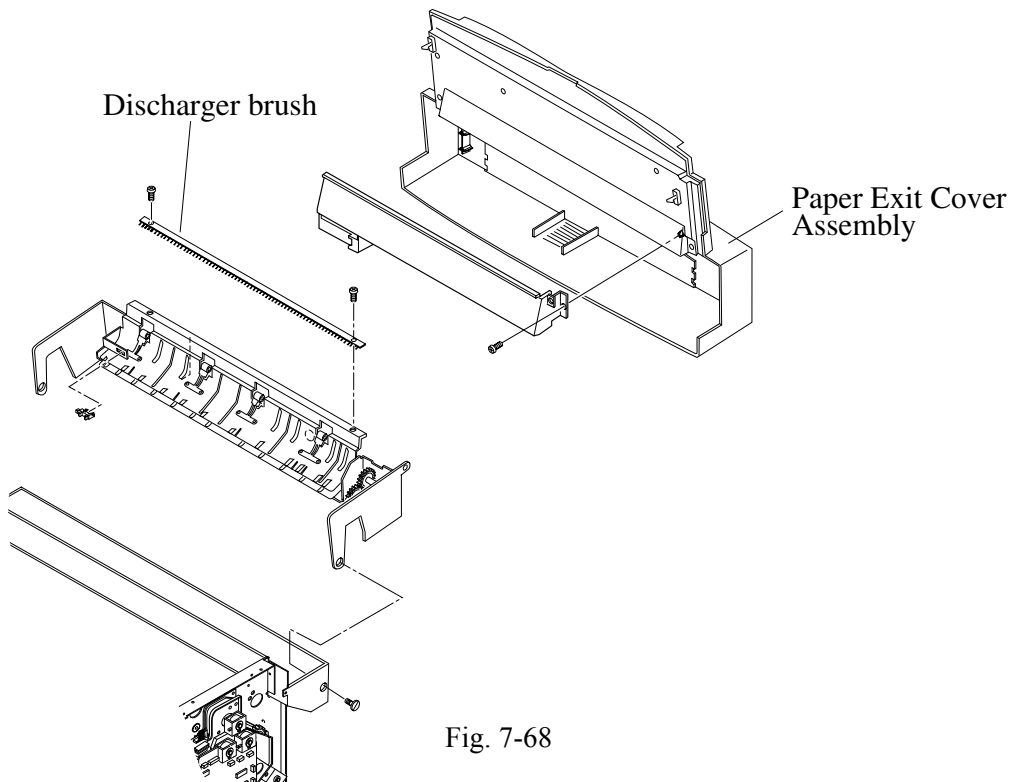

Fig. 7-68

7.6.7.3 Assembly Procedures

1. Install the new discharger brush into the paper exit unit.
2. Reassemble in reverse order of disassembly.

CAUTION:

Do not damage the bristles of the discharger brush.

7.6.8 Waste Toner Auger D (Stay 'A' Assembly)

- 7.6.8.1 Tool
#2 Phillips Screwdriver

CAUTION:

Do not touch or scratch the transfer drum. Do not damage the mylar seal of the waste toner auger D.

7.6.8.2 Disassembly Procedures (see Fig. 7-69)

1. Open the front door.
2. Open the top door.
3. Remove the belt cartridge.
4. Remove the toner cartridges.
5. Remove the drum cleaner.
6. Remove the left-upper side cover (see section 7.1.1).
7. Remove the top cover (see section 7.1.5).
8. Remove the set screw (ST4x6) of stay 'A'.
9. Pull up the stay 'A' assembly along the guide.

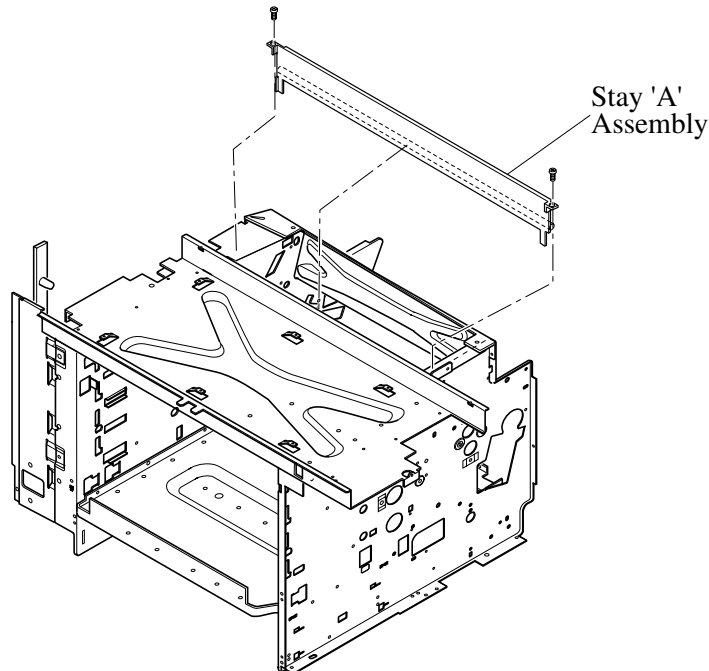

Fig. 7-69

7.6.8.3 Assembly Procedures

1. Reassemble in reverse order of disassembly.

7.6.9 Fuser Connector

7.6.9.1 Tools

Phillips Screwdrivers #1 and #2

7.6.9.2 Disassembly Procedures

(see Fig. 7-70)

1. Remove the fuser.
2. Remove the left side cover (see section 7.1.3).
3. Remove the shield case A assembly (see section 7.2.5.2[13]).
4. Remove the connector (BCN2) from the high voltage power supply.
5. Remove two set screws (SP3x8) from the fuser connector. Note that the set screw for the fuser connector is unique.
6. Remove the fuser connector.

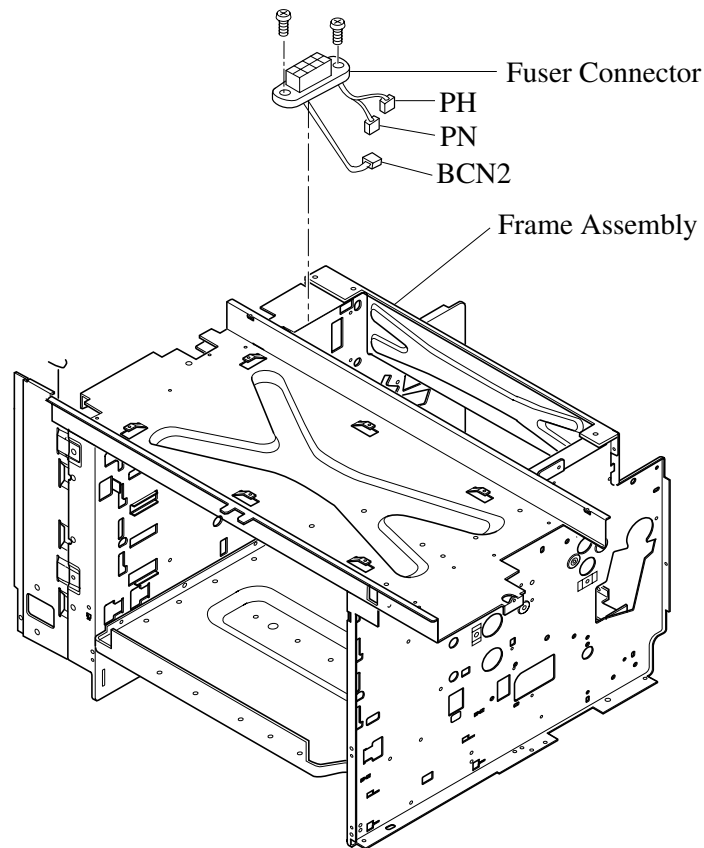

Fig. 7-70

7.6.9.3 Assembly Procedures

1. Install a new fuser connector.
2. Reassemble in reverse order of disassembly.

7.6.10 Toner Drive Assembly

7.6.10.1 Tools

Phillips Screwdrivers #1 and #2
Slotted Screwdriver

7.6.10.2 Disassembly Procedures

(see Fig. 7-71)

1. Remove the toner cartridges.
2. Remove the belt cartridge.
3. Remove the right side cover (see section 7.1.2).
4. Remove the ozone duct assembly (see section 7.3.8).
5. Remove the main gear unit (see section 7.3.2).
6. Remove one set screw (ST3x6) from the toner drive assembly.
7. Pull out the toner drive assembly toward you.

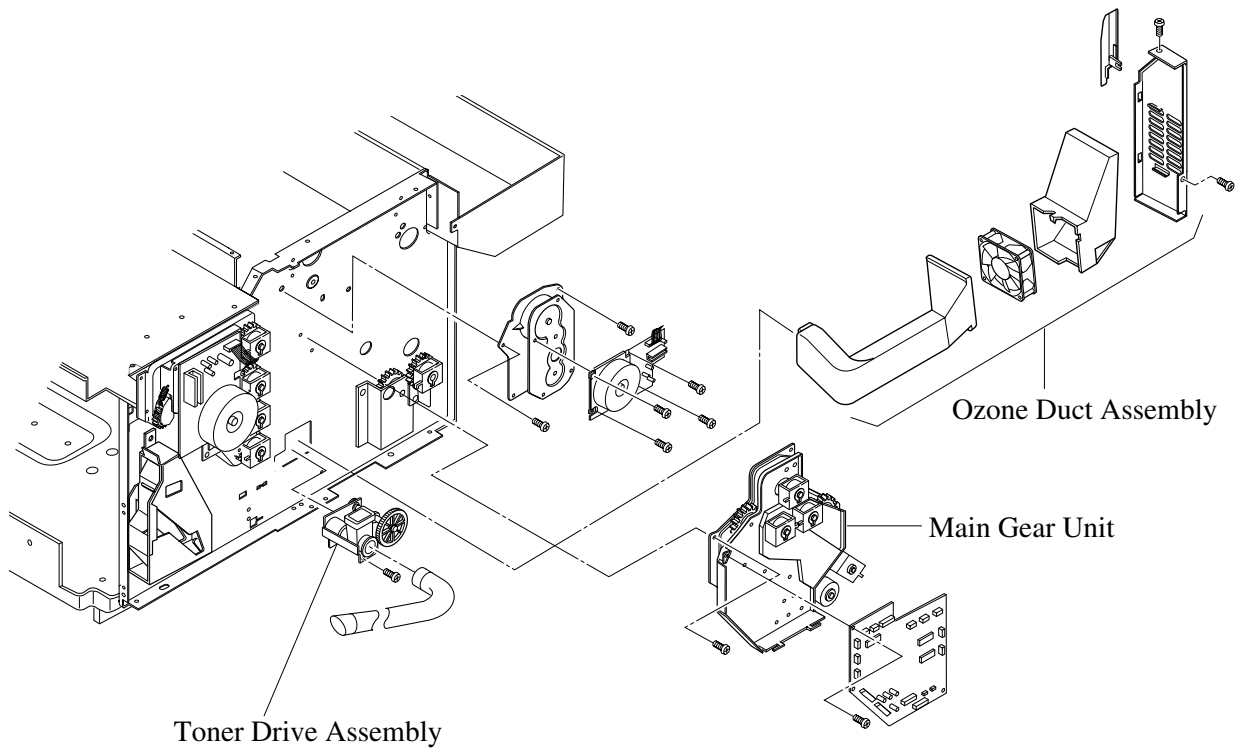

Fig. 7-71

7.6.10.3 Assembly Procedures

1. Install the toner drive assembly to the engine frame.
2. Reassemble in reverse order of disassembly.

7.7 Replacement of the Fuser

See section 5.3.3 for instructions on replacing the fuser (consumable).

CAUTION:

The fuser is very hot! Make sure that the fuser (and perimeter) is completely cooled before replacing parts.

The fuser contains silicone oil. Do not spill any silicone oil on the floor because it will become very slippery and dangerous.

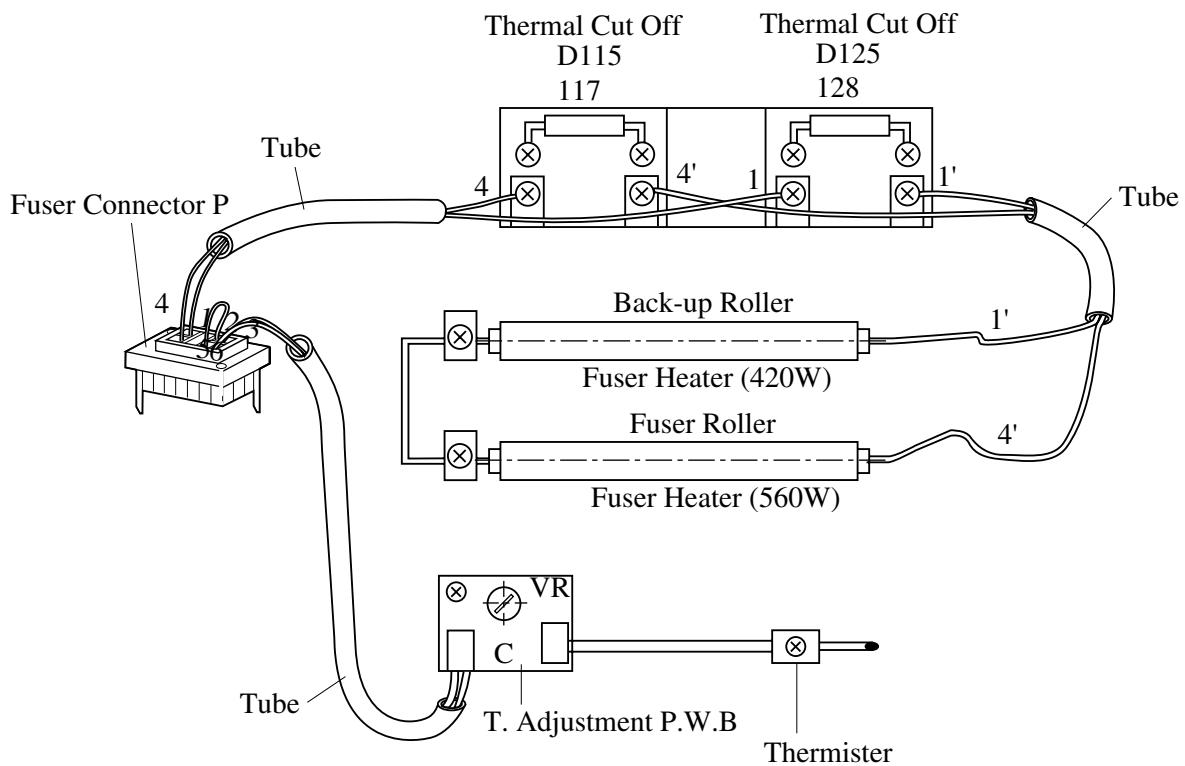

Fig. 7-72

7.7.1 Heater Lamp (HR/BR)

7.7.1.1 Tool

#1 Phillips Screwdriver

7.7.1.2 Disassembly Procedures

(see Fig. 7-72)

1. Remove the fuser.
2. Remove the F cover (L) by removing one fixing screw (ST3x6).
3. Remove the F cover (R) by removing one fixing screw (ST3x6).
4. Remove the F cover (B) by removing two fixing screws (ST3x6).
5. Remove the oil pan unit by removing two fixing screws (M3x6).
6. Remove two fixing screws (M3x6) from the heaters electrode base on the right side.
7. Remove two fixing screws (M3x6) from the heater harness temperature fuse base.
8. Remove four fixing screws (ST3x6) from the heater supports (HR/BR) right side.
9. Remove the heater (HR/BR) from each roller.

7.7.1.3 Assembly Procedures

1. Install each heater lamp through the roller so that it meets the electrode on the right side.
2. Install the left edge of the roller to the heater support, and then secure the heater support.
3. Secure the right side of the heater electrode to the electrode base with the fixing screw.
4. Secure the heater harness to the temperature fuse base electrode.
5. Reassemble in reverse order of disassembly.

CAUTION:

Do not touch the surface of heater lamp with dirty hands.

Wattages for the heater lamps are different between the fuser roller side and back-up roller side. Each wattage is marked on the insulator of the lamp's electrode:

Fuser roller side: 560W

Back-up roller side: 420W

7.7.2 Oil Pan Unit

7.7.2.1 Tools

Phillips Screwdrivers #1 and #2

7.7.2.2 Disassembly Procedures

(see Fig. 7-73)

1. Remove the fuser from the printer.
2. Remove the oil bottle and cleaning roller.
3. Remove two set screws (ST3x6) from the oil pan unit.
4. Remove the oil pan unit from the fuser.
5. Remove the oil pan unit making sure that no oil spills out of the oil pan. Lay the oil pan unit flat.

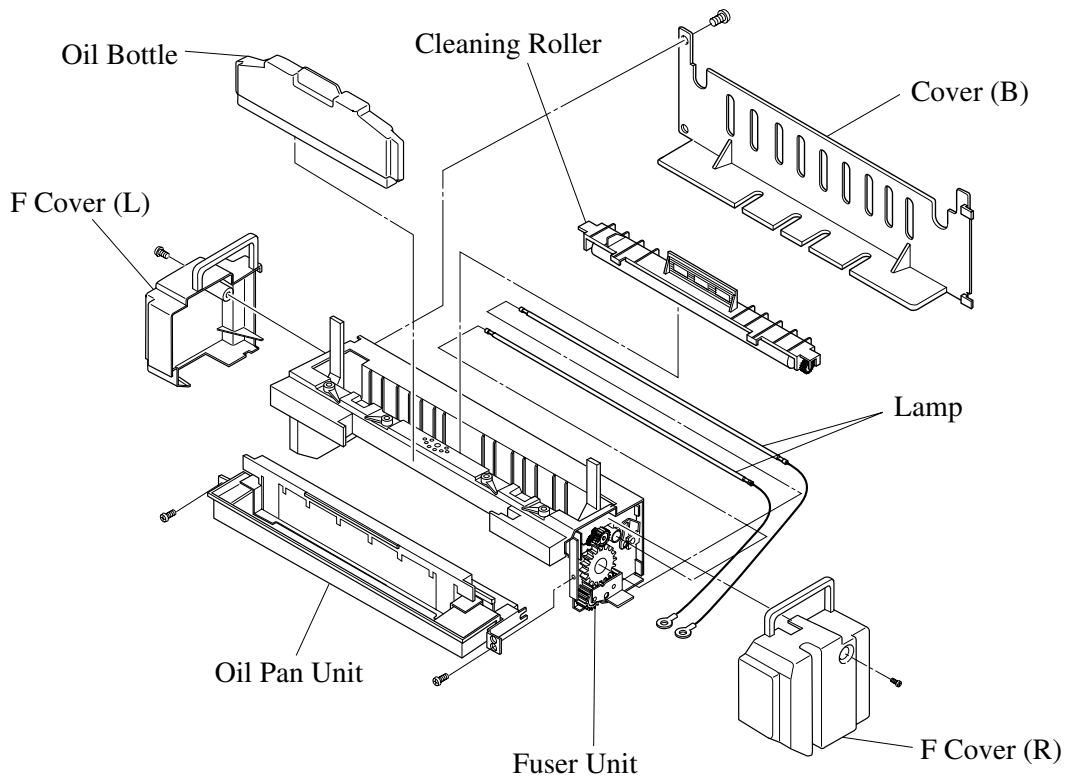

Fig. 7-73

7.7.2.3 Assembly Procedures

1. Prepare a new oil pan unit.
2. Install the new oil pan unit onto the fuser.
3. Reassemble in reverse order of disassembly.

7.8 Duplexer Replacement Procedures

Table 7-2: Table of Applicable Screws for the Duplexer

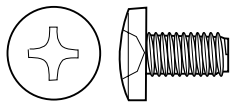
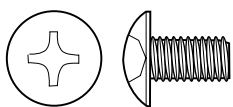
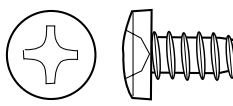
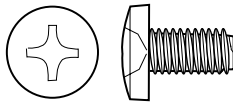
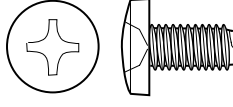
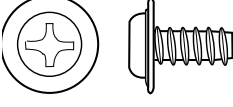
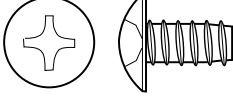
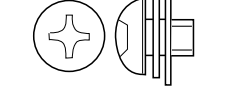
No.	Class Code	Name of Screw	Length	Shape	Remarks (Usage)
1	ST3X5	S Tight Screw	3X5		P.W.B. and Motor
2	ST3X14		3X14		Switch and Stopper Band
3	TM4X8	Truss Machine Screw	4X8		Top Cover
4	BT3X8	Cross-Recessed-Head-Tapping Screw	3X8		P.W.B. and Stopper Band
5	ST3X8	S Tight Screw	3X8		Sheet Metal
6	M4X30 M4X6	Cross-Recessed-Head-Tapping Screw (Pan Head)	4X30 4X6		Fan Frame
7	FT3X10	Flat Head Tapping Screw	3X10		Plastic
8	BT4X10	Cross-Recessed-Head-Tapping Screw	4X10		Bottom Cover
9	M4X8	Cross-Recessed-Head-Tapping with washer	M4X8		Frame

7.8.1 Replacement of Covers and Paper Guides

7.8.1.1 Lower-right Cover

7.8.1.1.1 Tool

#1 Phillips Screwdriver

7.8.1.1.2 Disassembly Procedures

(see Fig. 7-74)

1. Remove two set screws (TS4x8) from the lower-right cover.
2. Remove the lower-right cover from the duplexer.

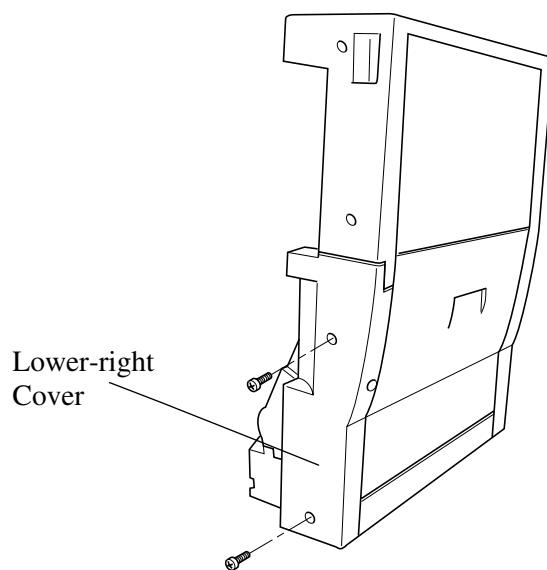

Fig. 7-74

7.8.1.1.3 Assembly Procedures

1. Reassemble in reverse order of disassembly.

7.8.1.2 Lower-left Cover

7.8.1.2.1 Tool

#1 Phillips Screwdriver

7.8.1.2.2 Disassembly Procedures

(see Fig. 7-75)

1. Remove two set screw (ST4x8) from the lower-left cover.
2. Remove the lower-left cover from the duplexer.

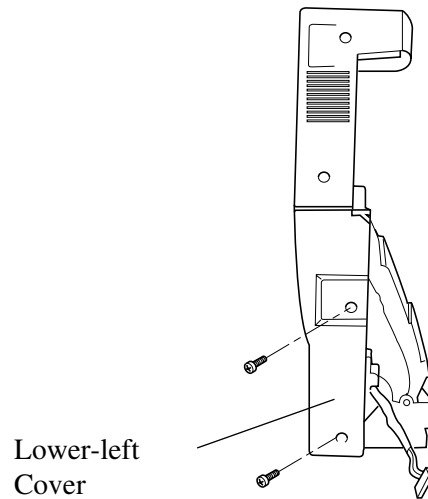

Fig. 7-75

7.8.1.2.3 Assembly Procedures

1. Install the new lower-left cover.
2. Reassemble in reverse order of disassembly.

7.8.1.3 Top-right Cover

7.8.1.3.1 Tool

#1 Phillips Screwdriver

7.8.1.3.2 Disassembly Procedures

(see Fig. 7-76)

1. Remove two set screws (ST4x8) from the top-right cover.
2. Remove the top-right cover from the duplexer.

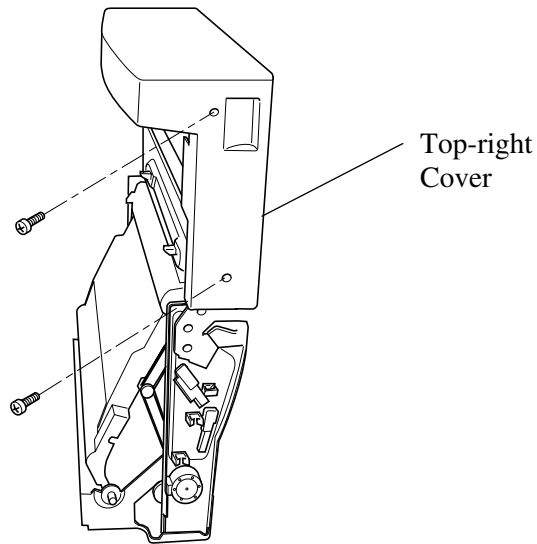

Fig. 7-76

7.8.1.3.3 Assembly Procedures

1. Install the new top-right cover.
2. Reassemble in reverse order of disassembly.

7.8.1.4 Top-left Cover

7.8.1.4.1 Tool

#1 Phillips Screwdriver

7.8.1.4.2 Disassembly Procedures

(see Fig. 7-77)

1. Remove the lower-left cover (see section 7.8.1.2).
2. Remove two set screws (ST4x8) from top-left cover.
3. Remove the top-left cover from the duplexer.

Cover Top (L)

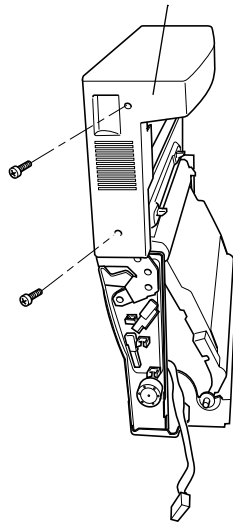

Fig. 7-77

7.8.1.4.3 Assembly Procedures

1. Reassemble in reverse order of disassembly.

7.8.1.5 Top-rear Cover with Guide Rollers
Includes four guide rollers.

7.8.1.5.1 Tool
#2 Phillips Screwdriver

7.8.1.5.2 Disassembly Procedures
(see Fig. 7-78 and Fig. 7-79)

1. Remove four set screws (TS3x8) from the top-rear cover.
2. Remove the top-rear cover from the Top Unit.
3. Remove three set screws (TS3x8) from the top-rear cover paper guide.
4. Remove the top-rear cover paper guide from the top-rear cover.

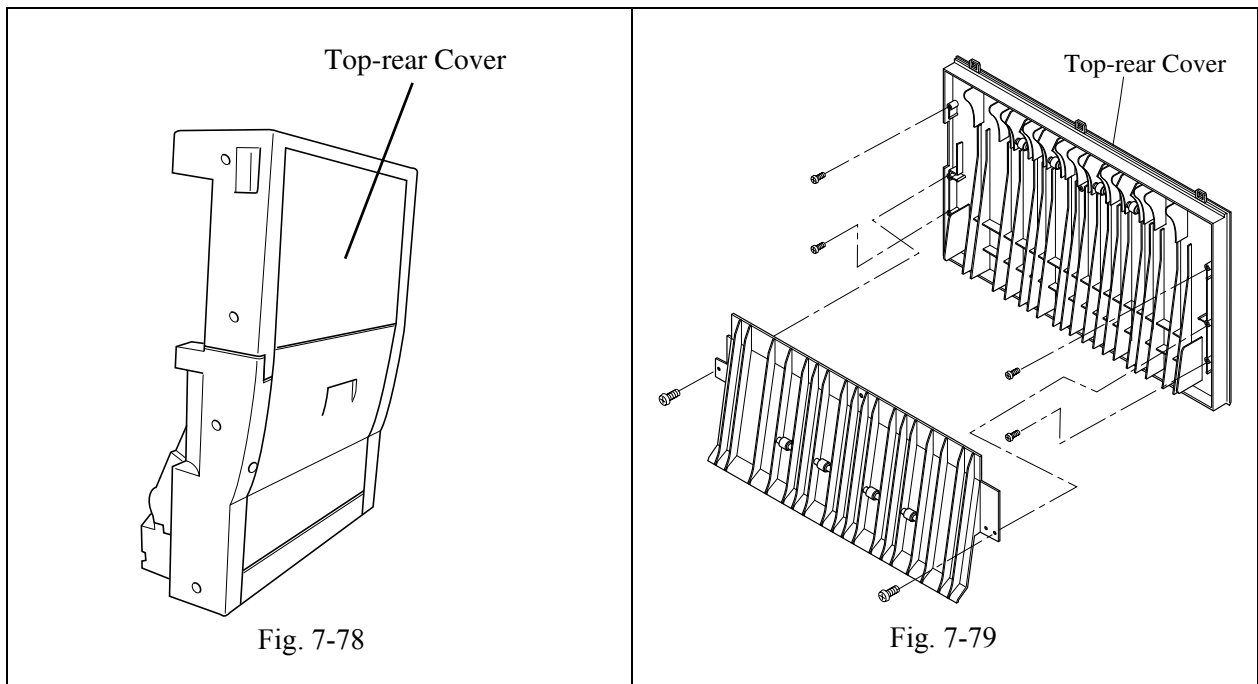

7.8.1.5.3 Assembly Procedures

1. Reassemble in reverse order of disassembly.

7.8.1.6 Top Cover

7.8.1.6.1 Tool
#2 Phillips Screwdriver

7.8.1.6.2 Disassembly Procedures
(see Fig. 7-80 and Fig. 7-81)

1. Remove four set screws (TS3x8) from the top cover.
2. Remove the top cover.

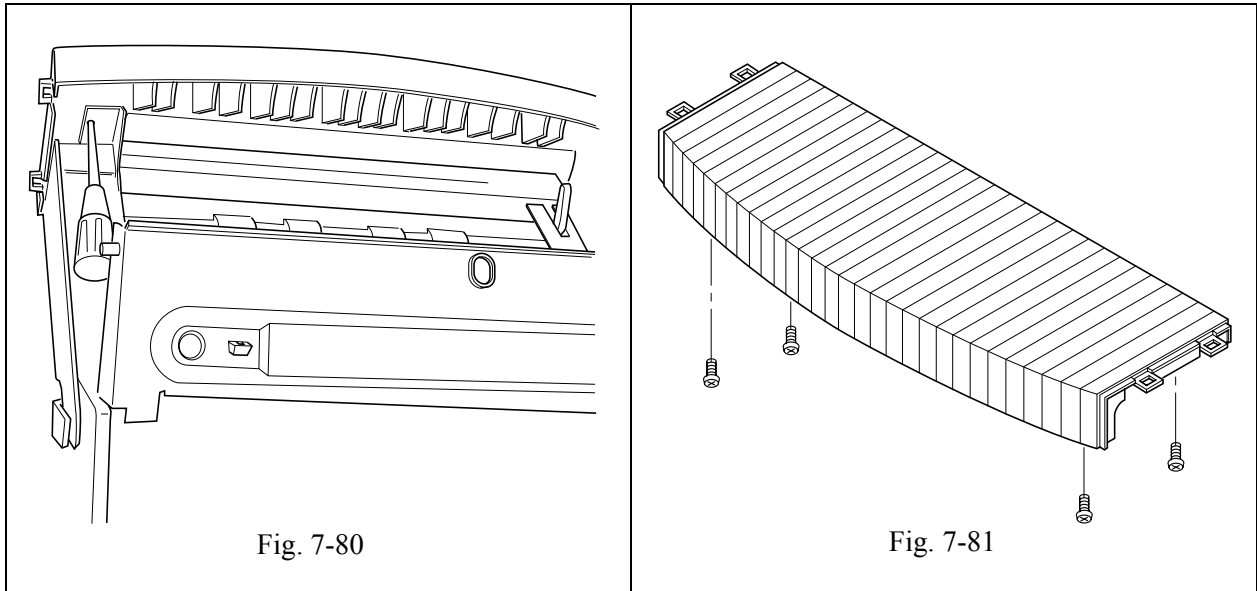

7.8.1.6.3 Assembly Procedures

1. Reassemble in reverse order of disassembly.

7.8.1.7 Lower-rear Cover

Includes four guide rollers, handle, and lock lever.

7.8.1.7.1 Tool

#2 Phillips Screwdriver

7.8.1.7.2 Disassembly Procedures

(see Fig. 7-82 and Fig. 7-83)

1. Open the lower-rear door.
2. Remove four set screws (TS3x8) from lower-rear cover.
3. Remove the lower-rear cover from the hinge metal fixture.

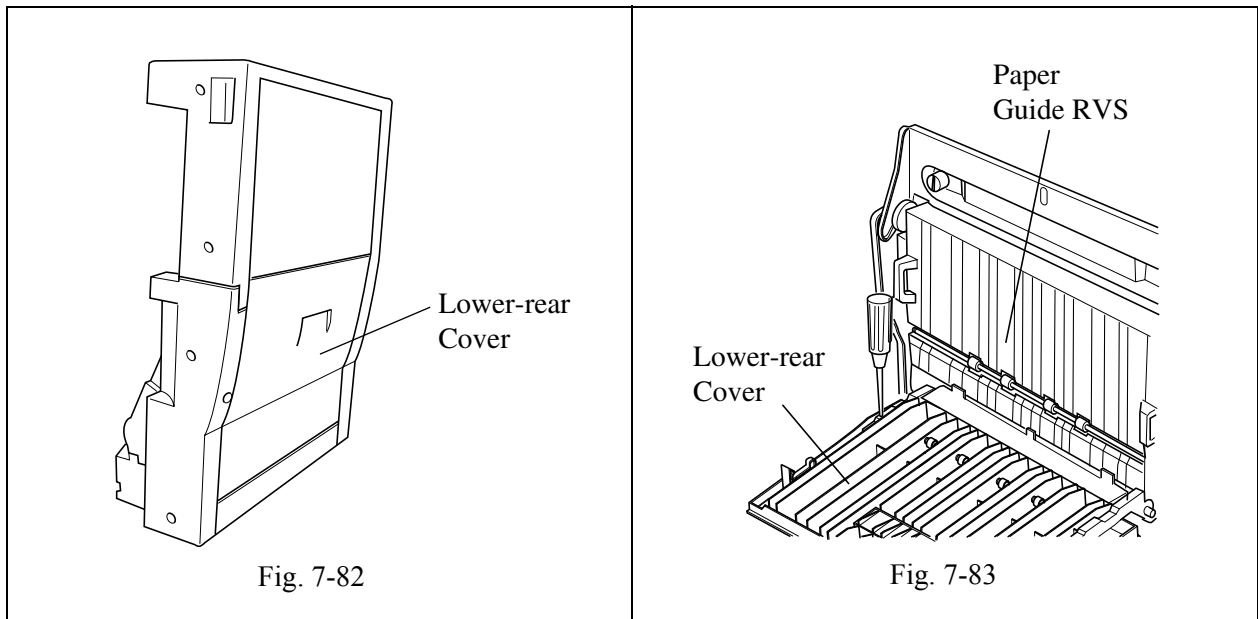

7.8.1.7.3 Assembly Procedures

1. Reassemble in reverse order of disassembly.

7.8.1.8 Bottom Cover

7.8.1.8.1 Tool

Phillips Screwdriver

7.8.1.8.2 Disassembly Procedures

(see Fig. 7-84 and Fig. 7-85)

1. Remove the lower-rear cover (see section 7.8.1.7).
2. Remove the harness cover.
3. Remove two set screws (M4x6) from the bottom cover.
4. Remove the harness inside the bottom cover.
5. Remove the bottom cover from the base.

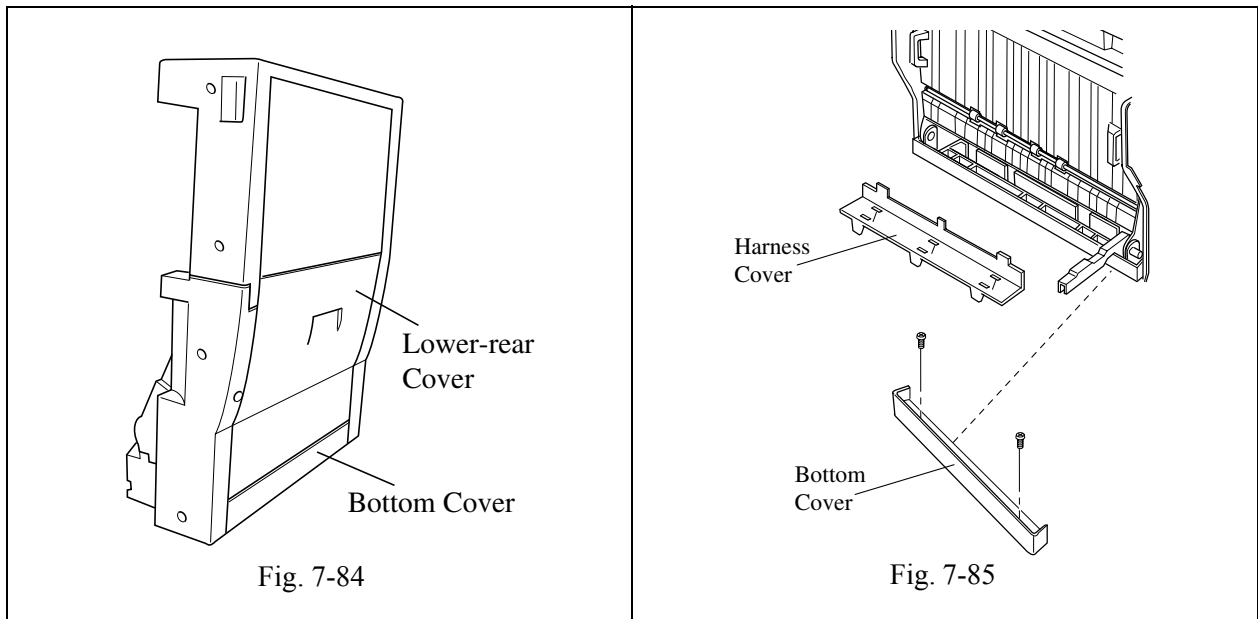

7.8.1.8.3 Assembly Procedures

1. Reassemble in reverse order of disassembly.

7.8.1.9 Reverse Paper Guide Unit

7.8.1.9.1 Tool

#1 Phillips Screwdriver

7.8.1.9.2 Disassembly Procedures

(see Fig. 7-86 and Fig. 7-87)

1. Remove the lower-right and lower-left covers (see section 7.8.1.1 and section 7.8.1.2).
2. Remove the bottom paper guide (section 7.8.1.11).
3. Remove the four set screws (ST3x6) from the support shaft ends.
4. Remove lower-rear cover (section 7.8.1.7).
5. Remove the support shaft from the frame.
6. Remove the retaining band from the reverse paper guide unit.
7. Remove the reverse paper guide unit from the frame.
8. Remove the harness connected with the connector CN2 of Relay P.W.B.

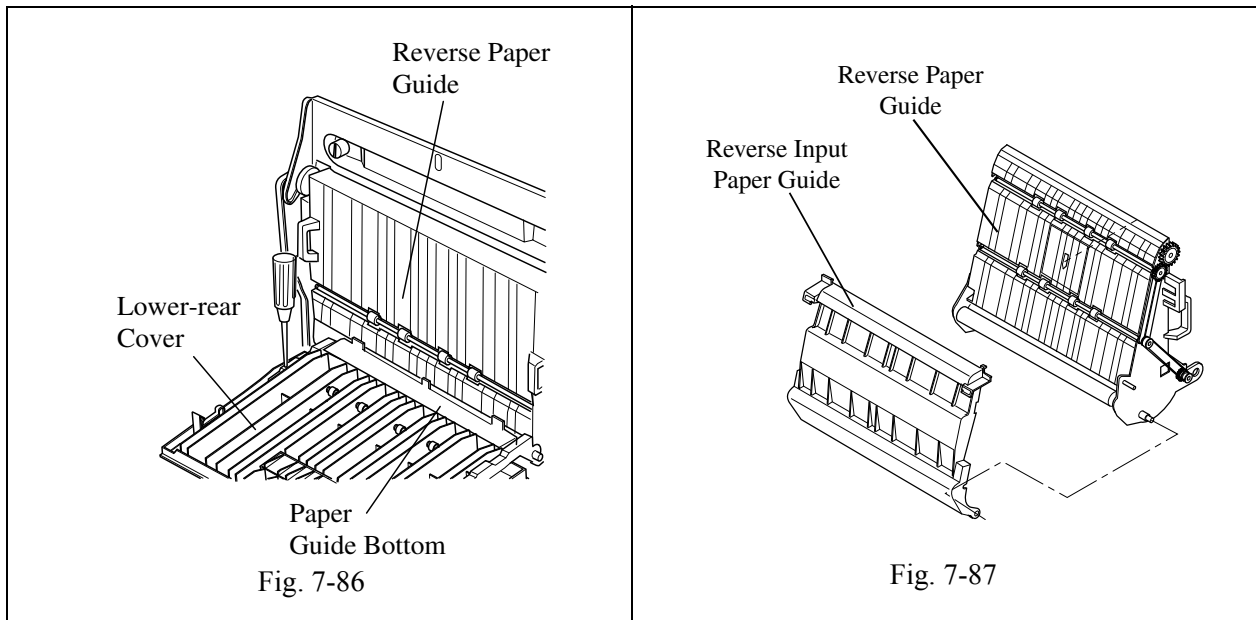

7.8.1.9.3 Assembly Procedures

1. Reassemble in reverse order of disassembly.

7.8.1.10 Reverse Input Paper Guide

7.8.1.10.1 Disassembly Procedures

(see Fig. 7-88 and Fig. 7-89)

1. Open the lower-rear cover.
2. Open the reverse paper guide unit.
3. Remove the support part of reverse input paper guide from the shaft.
4. Remove the reverse input paper guide.

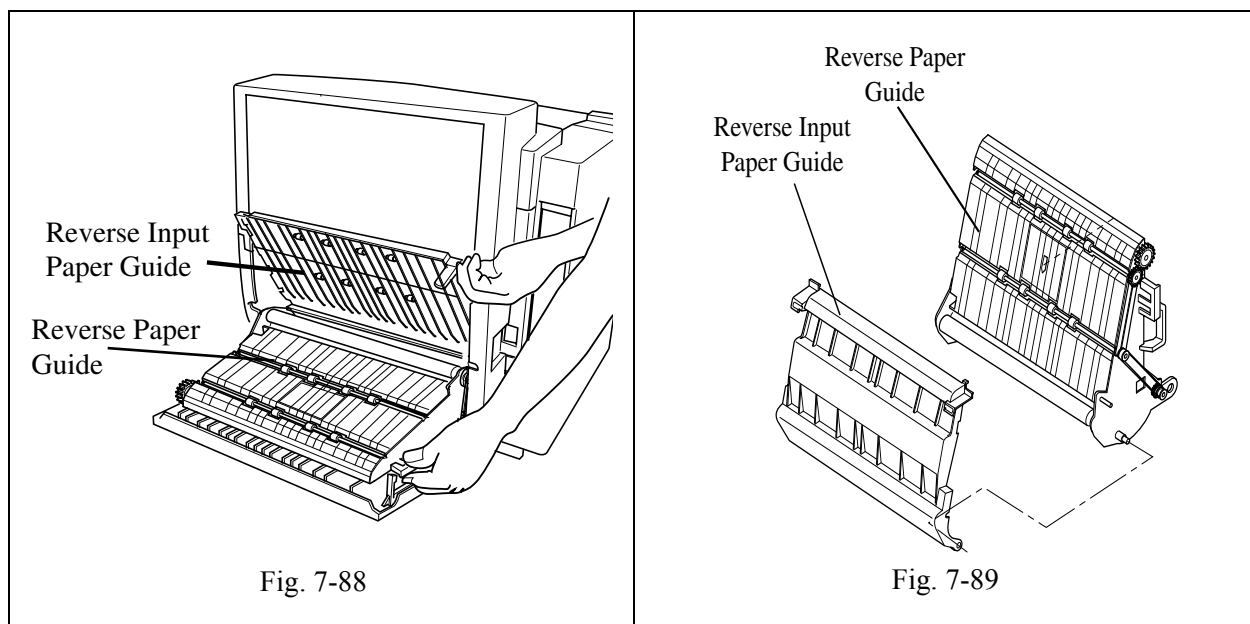

7.8.1.10.2 Assembly Procedures

1. Reassemble in reverse order of disassembly.

7.8.1.11 Bottom Paper Guide

7.8.1.11.1 Tool

#2 Phillips Screwdriver

7.8.1.11.2 Disassembly Procedures

(see Fig. 7-90)

1. Open the lower-rear door.
2. Open the Reverse Paper Guide Unit.
3. Remove two set screws (ST3x6) from the bottom paper guide.
4. Remove the bottom paper guide.

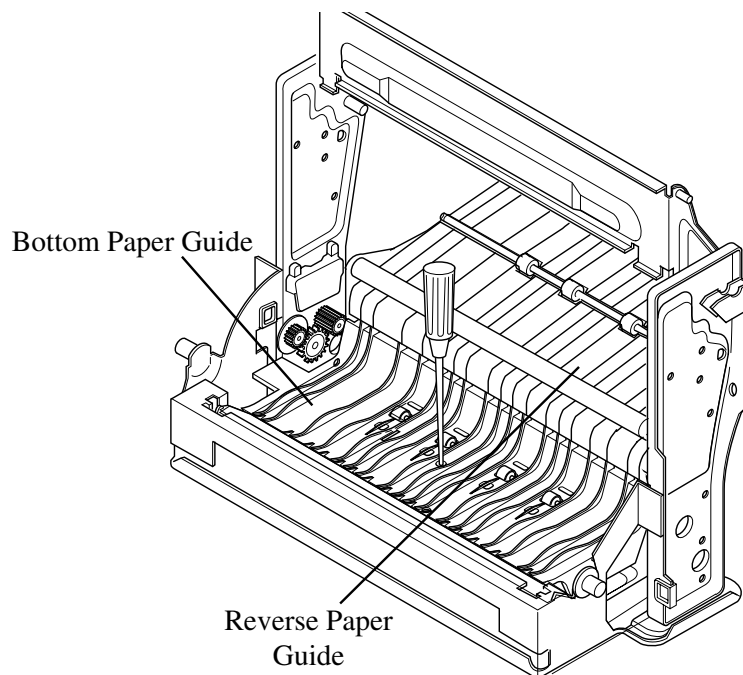

Fig. 7-90

7.8.1.11.3 Assembly Procedures

1. Reassemble in reverse order of disassembly.

7.8.2 Separation of the Top and Lower Units

7.8.2.1 Tools

Phillips Screwdrivers #1 and #2

7.8.2.2 Disassembly Procedures

(see Fig. 7-91 to Fig. 7-92)

1. Remove lower-right and lower-left covers (see section 7.8.1.1 and section 7.8.1.2).
2. Remove the solenoid connector, and remove the harness from the clamp.
3. Remove the fan connector, and remove the harness from the clamp.
4. Remove one set screw (M4x) support pin from both sides.
5. Separate the top unit from the lower unit.

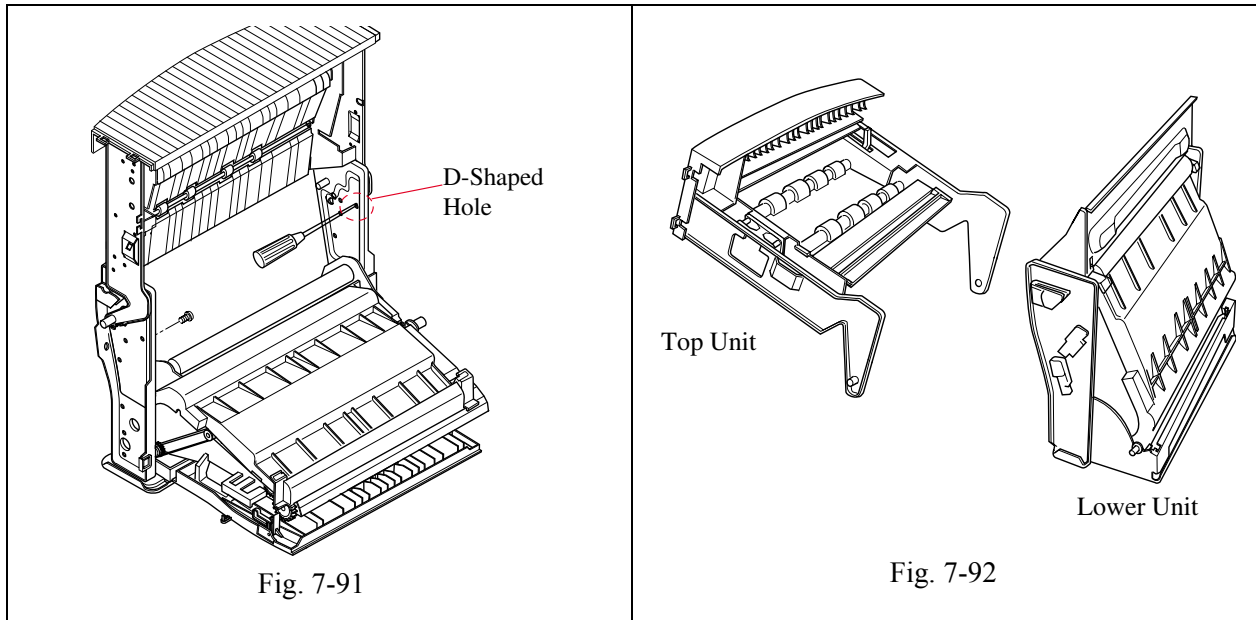

7.8.2.3 Assembly Procedures

1. Reassemble in reverse order of disassembly.

7.8.3 Replacement of Print P.W.B.s

7.8.3.1 Duplexer P.W.B.

7.8.3.1.1 Tools

Phillips Screwdrivers #1 and #2

7.8.3.1.2 Disassembly Procedures

(see Fig. 7-93 and Fig. 7-94)

1. Remove the bottom paper guide (see section 7.8.1.11).
2. Remove all connectors from the Duplexer P.W.B.
3. Remove four set screws (ST3x6) from the Duplexer P.W.B.
4. Remove the Duplexer P.W.B.

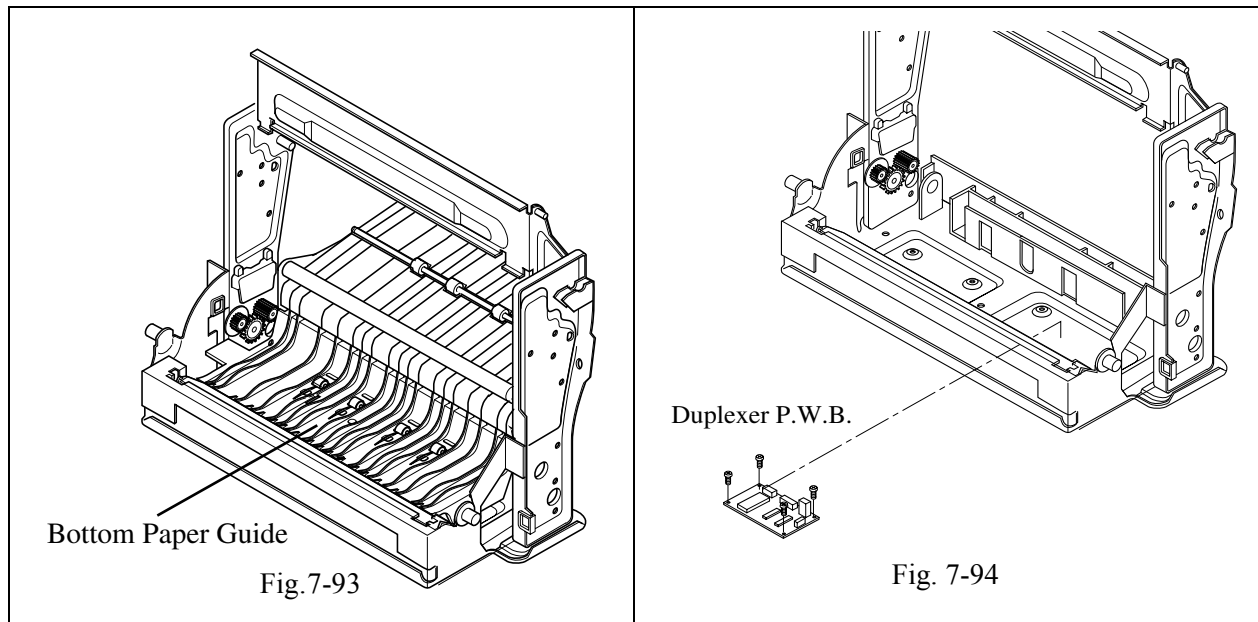

7.8.3.1.3 Assembly Procedures

1. Reassemble in reverse order of disassembly.

7.8.3.2 Relay P.W.B.

7.8.3.2.1 Tool

#1 Phillips Screwdriver

7.8.3.2.2 Disassembly Procedures

(see Fig. 7-95 and Fig. 7-96)

1. Remove the bottom paper guide (see section 7.8.1.11).
2. Remove all connectors from the Relay P.W.B.
3. Remove four set screws (ST3x6) from the Relay P.W.B.
4. Remove the Relay P.W.B.

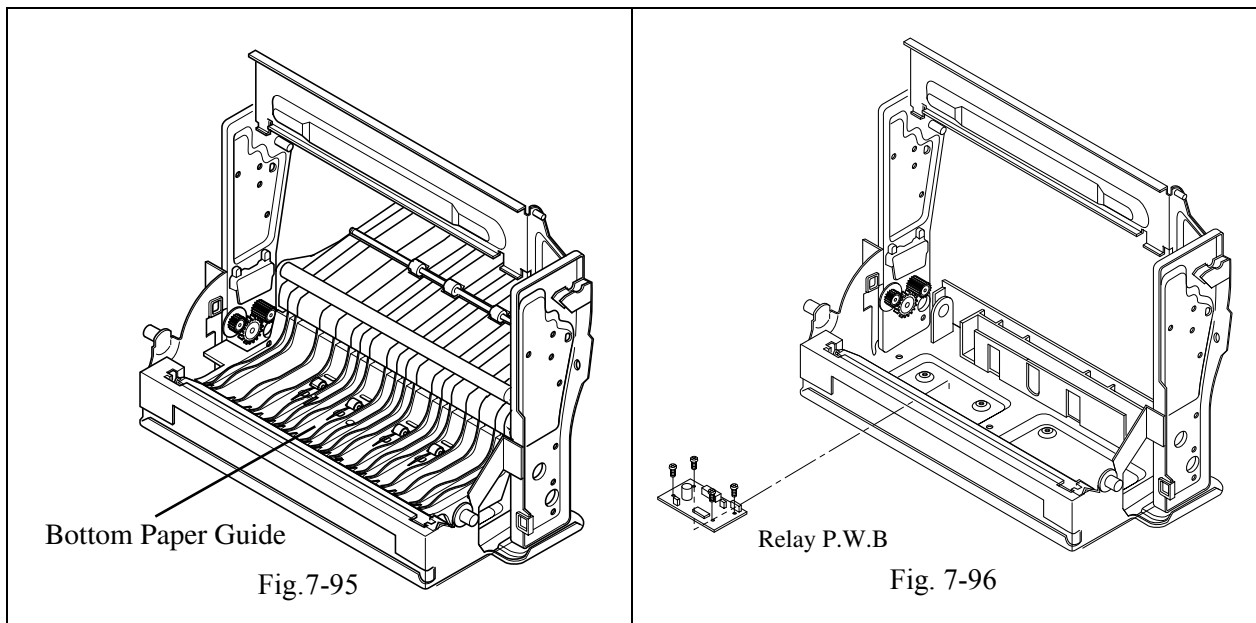

7.8.3.2.3 Assembly Procedures

1. Reassemble in reverse order of disassembly.

7.8.4 Replacement of Motors

7.8.4.1 Motor (1)

7.8.4.1.1 Tool

#1 Phillips Screwdriver

7.8.4.1.2 Disassembly Procedures

(see Fig. 7-97, Fig. 7-98 and Fig. 7-99)

1. Remove the bottom paper guide (see section 7.8.1.111) and the reverse paper guide unit (see section 7.8.1.9).
2. Remove the motor harness connector CN5 from the Relay P.W.B.
3. Remove the harness cover, then remove the harness from the clamp.
4. Remove the protective cover.
5. Remove the belt from the motor shaft.
6. Remove two set screws (ST3x6) from the motor (1).
7. Remove the motor (1) from the frame.

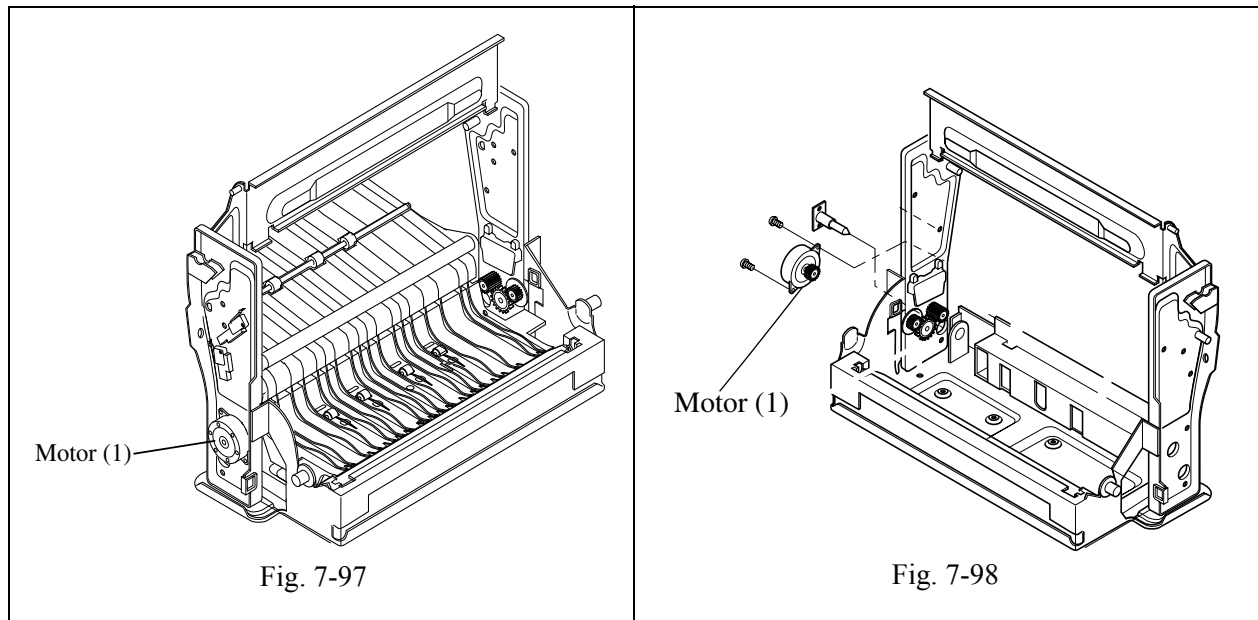

7.8.4.1.3 Assembly Procedures

1. Reassemble in reverse order of disassembly.

7.8.4.2 Motor (2)

7.8.4.2.1 Tool

#1 Phillips Screwdriver

7.8.4.2.2 Disassembly Procedures

(see Fig. 7-99)

1. Remove the bottom paper guide (see section 7.8.1.11) and the reverse paper guide unit (see section 7.8.1.9).
2. Remove the motor harness connector CN7 from the Relay P.W.B.
3. Remove the harness from the clamp.
4. Remove the protective cover.
5. Remove two set screws (ST3x6) from the motor (2).
6. Remove the motor (2) from the frame.

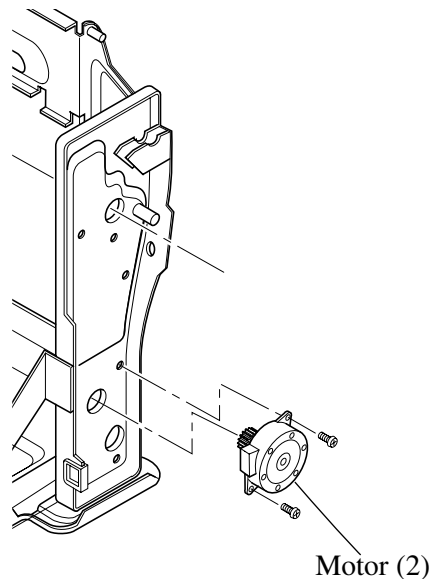

Fig. 7-99

7.8.4.2.3 Assembly Procedures

1. Reassemble in reverse order of disassembly.

7.8.4.3 Fan Motor

7.8.4.3.1 Tools

Phillips Screwdrivers #1 and #2

7.8.4.3.2 Disassembly Procedures

(see Fig. 7-100)

1. Remove the lower-left cover (see section 7.8.1.2).
2. Remove the top-left cover (see section 7.8.1.4).
3. Disconnect the fan harness connector.
4. Remove the harness from the clamp.
5. Remove two set screws (M4x30, 2 pcs.) from the fan.
6. Remove the Fan Motor from the frame.

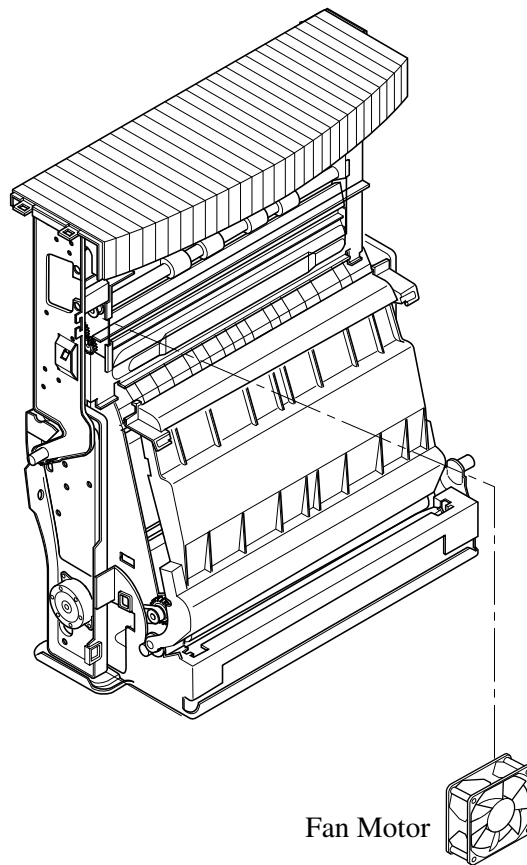

Fig. 7-100

7.8.4.3.3 Assembly Procedures

1. Reassemble in reverse order of disassembly.

7.8.5 Replacement of Solenoid Assemblies

7.8.5.1 Upper Solenoid Assembly

7.8.5.1.1 Tools

Phillips Screwdrivers #1 and #2

7.8.5.1.2 Disassembly Procedures

(see Fig. 7-101)

1. Remove the top-right cover (section 7.8.1.3)
2. Remove the lower-right cover (section 7.8.1.1)
3. Disconnect the solenoid harness connector.
4. Remove the harness from the clamp.
5. Remove two set screws (ST3x6) from the upper solenoid assembly.

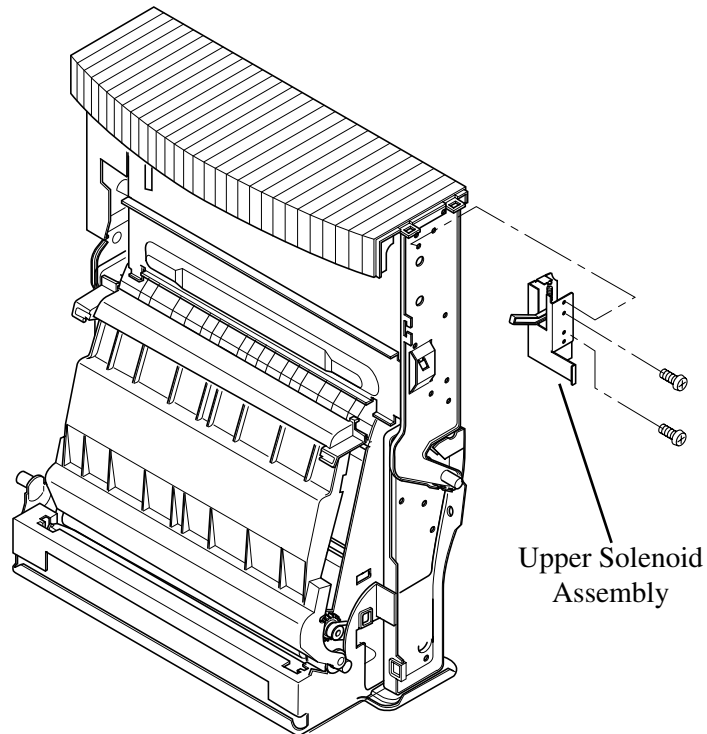

Fig. 7-101

7.8.5.1.3 Assembly Procedures

1. Reassemble in reverse order of disassembly.

7.8.5.2 Lower Solenoid Assembly

7.8.5.2.1 Tools

Phillips Screwdrivers #1 and #2

7.8.5.2.2 Disassembly Procedures

(see Fig. 7-102)

1. Remove two set screws (ST3x6) from the bottom paper guide.
2. Remove the bottom paper guide.
3. Remove the harness cover.
4. Remove the lower solenoid assembly motor harness connector CN3 from the Relay P.W.B.
5. Remove the harness from the clamp.
6. Remove the solenoid assembly.

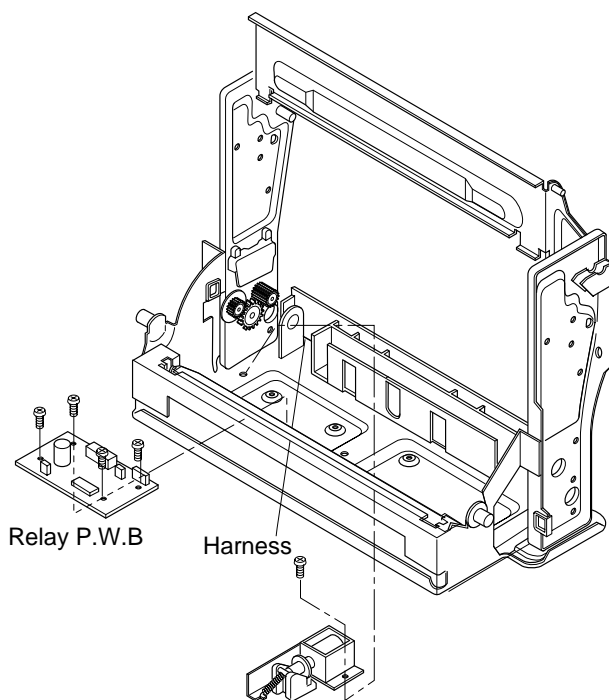

Fig. 7-102

CAUTION:

Put the Actuator in the hole of the Switching Shutter L while assembling the Lower Solenoid Assembly.

7.8.5.2.3 Assembly Procedures

1. Reassemble in reverse order of disassembly.

7.8.6 Replacement of Sensors and Switches

7.8.6.1 Interlock Switches (1 and 2)

Switch 1: Interlock Switch used to sense an open upper-rear door.

Switch 2: Interlock Switch used to sense an open lower-rear door.

7.8.6.1.1 Tools

#2 Phillips Screwdriver

7.8.6.1.2 Disassembly Procedures

(see Fig. 7-103)

1. Remove the lower-left cover (see section 7.8.1.2).
2. Remove one set screw (ST3x12) from the appropriate interlock switch.
3. Remove the harness connector from the appropriate interlock switch.

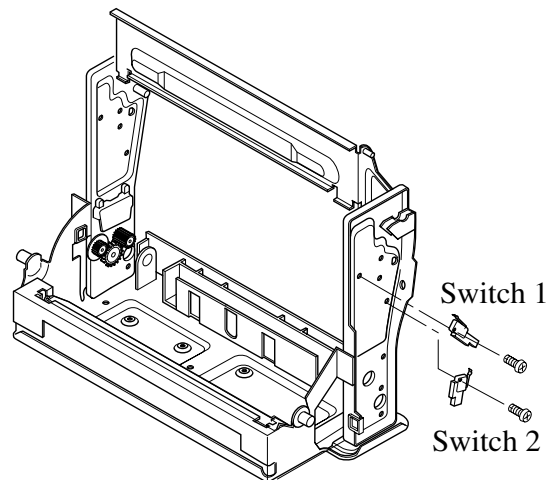

Fig. 7-103

7.8.6.1.3 Assembly Procedures

1. Attach the harness connector to the new interlock switch.
2. Attach the interlock switch to the frame.
3. Reassemble in reverse order of disassembly.

7.8.6.2 Interlock Switches (3 and 4)

Switch 3: Interlock switch used to sense an open top-rear door.

Switch 4: Interlock switch used to sense an open lower-rear door.

7.8.6.2.1 Tool

Phillips Screwdriver

7.8.6.2.2 Disassembly Procedures

(see Fig. 7-104)

1. Remove the lower-right cover (see section 7.8.1.1).
2. Remove one set screw (ST3x12) from the appropriate interlock switch.
3. Remove the harness connector from the appropriate interlock switch.

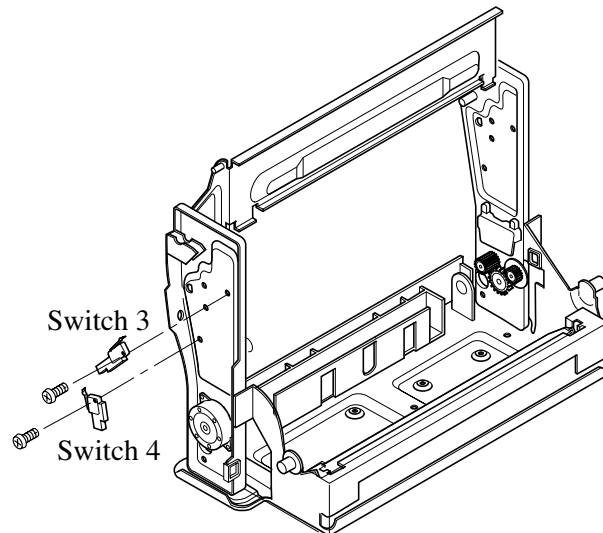

Fig. 7-104

7.8.6.2.3 Assembly Procedures

1. Connect the harness connector.
2. Attach the appropriate interlock switch to the frame.
3. Reassemble in reverse order of disassembly.

7.8.6.3 Paper Sensor PT5

7.8.6.3.1 Tools

Phillips Screwdriver

7.8.6.3.2 Disassembly Procedures

(see Fig. 7-105)

1. Open the lower-rear door.
2. Open the reverse input paper guide.
3. Remove the sensor cover.
4. Remove the paper sensor PT5 from the reverse paper guide unit.

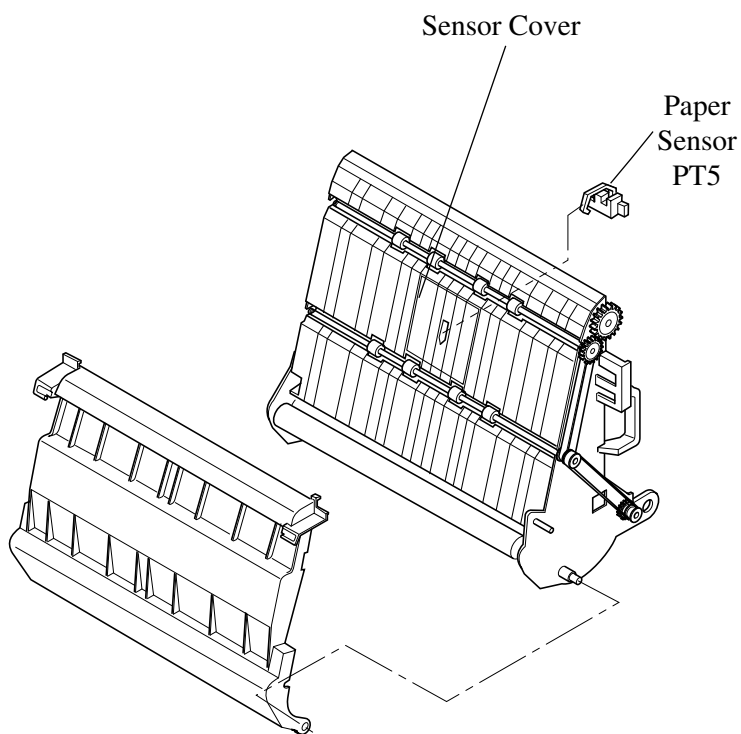

Fig. 7-105

7.8.6.3.3 Assembly Procedures

1. Attach and connect the new Paper Sensor PT5 to the reverse paper guide unit.
2. Reassemble in reverse order of disassembly.

7.8.6.4 Paper Sensor Low PT4

7.8.6.4.1 Tool
Phillips Screwdriver

7.8.6.4.2 Disassembly Procedures
(see Fig. 7-106 and Fig. 7-107)

1. Remove the bottom paper guide.
2. Remove the harness cover.
3. Disconnect the CN6 connector from the Relay P.W.B.
4. Remove the Paper Sensor Low from the bottom paper guide assembly.

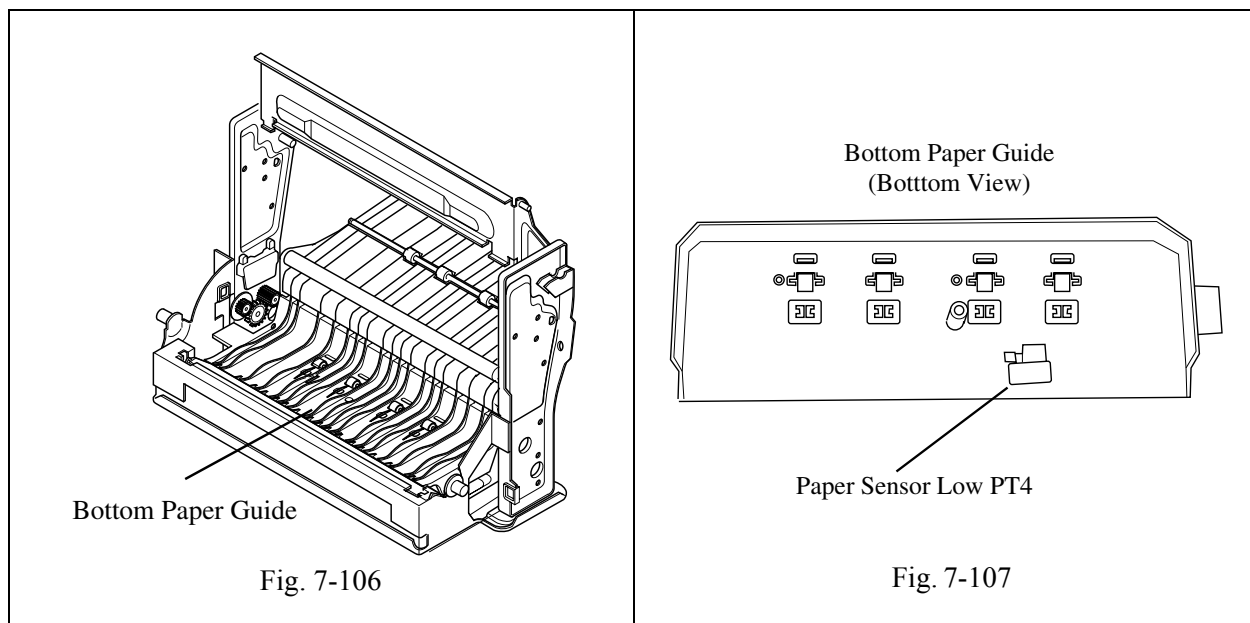

7.8.6.4.3 Assembly Procedures
1. Reassemble in reverse order of disassembly.

7.9 Replacement of Lower Feed Unit Parts

7.9.1 Paper Sensor PEL

7.9.1.1 Tool

#1 Phillips Screwdriver

7.9.1.2 Disassembly Procedures

(see Fig. 7-108)

1. Open the LFU back door.
2. Remove the LFU paper guide by removing four set screws (ST3x6).
3. Remove the paper guide assembly (PGA) by removing the set screw (ST3x6).
4. Disconnect the Paper Sensor connector.
5. Remove the Paper Sensor by removing two set screws (ST3x6).

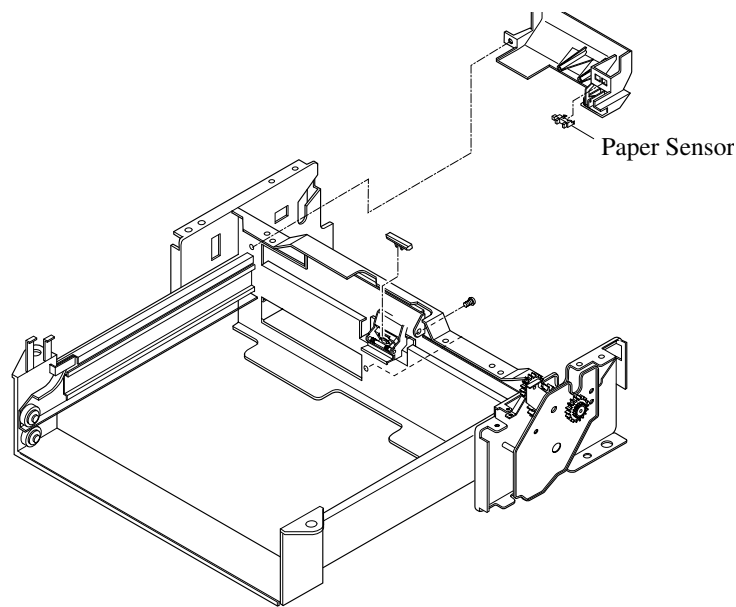

Fig. 7-108

7.9.1.3 Assembly Procedures

1. Reassemble in reverse order of disassembly.

7.9.2 Paper Size Sensor (SL3-PS -A57 P.W.B. Assembly)

7.9.2.1 Tool

#1 Phillips Screwdriver

7.9.2.2 Disassembly Procedures

(see Fig. 7-109)

1. Open the LFU back door.
2. Remove the LFU paper guide by removing four set screws (ST3x6).
3. Remove the paper size sensor from the paper feeder base by removing two set screws (ST3x6).
4. Disconnect the paper size sensor connector.
5. Remove the paper size sensor.

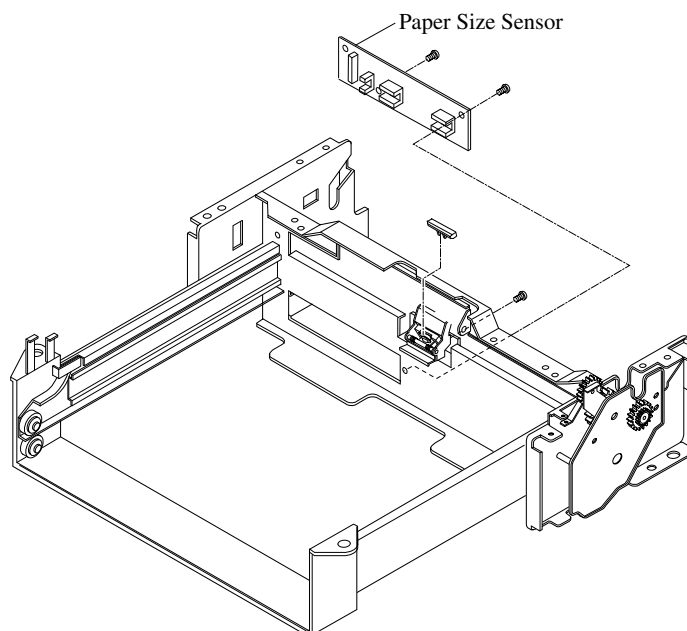

Fig. 7-109

7.9.2.3 Assembly Procedures

1. Reassemble in reverse order of disassembly.

7.9.3 Paper Feeder Clutch (PKCLL) / Paper Transportation Clutch (DPKCL)

7.9.3.1 Tools

Phillips Screwdrivers #1 and #2

7.9.3.2 Disassembly Procedures

(see Fig. 7-110 and Fig. 7-111).

1. Remove the LFU from the printer.
2. Remove the pawl on the right side cover, unhook the hook at LFU side, and then remove the right side cover.
3. Remove the LFU back door.
4. Remove the LFU paper guides by removing four set screws (ST3x6).
5. Remove the paper guide assembly by removing one set screw (ST3x6).

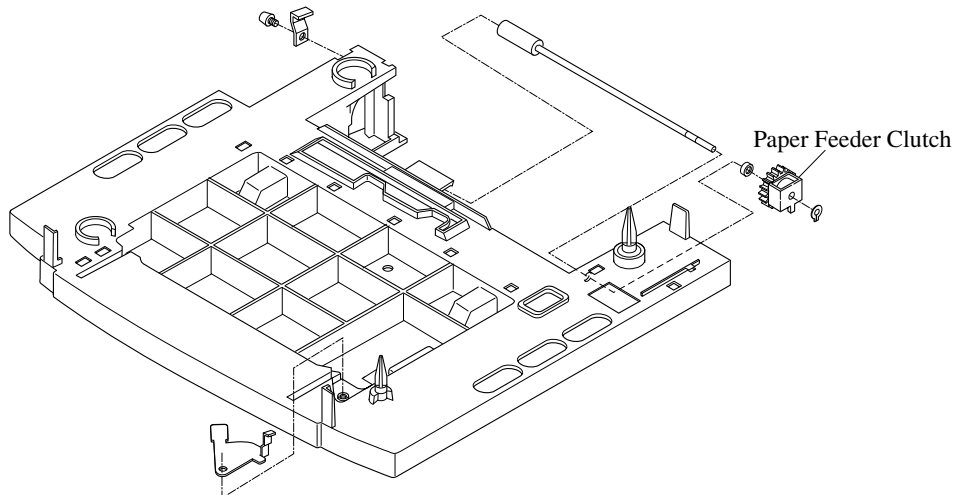

Fig. 7-110

6. Remove the left base cover.
 - a. Remove the anchor (foot).
 - b. Remove the rubber foot (1 pc.).
 - c. Remove two set screws (ST4x10).
 - d. Lift the left base cover straight up so that it comes out of the adjuster base pin smoothly, and then remove the left base cover.
7. Remove the right base cover.
 - a. Remove the rubber foot (back side 1 pc.) by removing one set screw (ST4x10 (1 pc.)).
 - b. Remove two set screws (TS4x10).
 - c. Lift the right base cover straight up so that it comes out of the adjuster base pin smoothly, and then remove the right base cover.

8. Disconnect the clutch connector clutch.
9. Remove the LFU top cover.
 - a. Remove the LFU harness clamp by removing one set screw (ST4x8).
 - b. Remove seven set screws (ST4x8).
 - c. Check the five boss pin locations for reassembly.
10. Remove the stopper washer of the paper feeder clutch, and pull out the paper feeder clutch from the shaft.
11. Remove the paper transportation clutch.
 - a. Remove the fixing washer from the inside of bearing.
 - b. Slide the shaft from the top cover.
 - c. Remove the paper transportation part (rubber roller) from the bearing.
 - d. Remove the fixing washer from the paper transportation clutch, and pull the paper transportation clutch from the shaft.

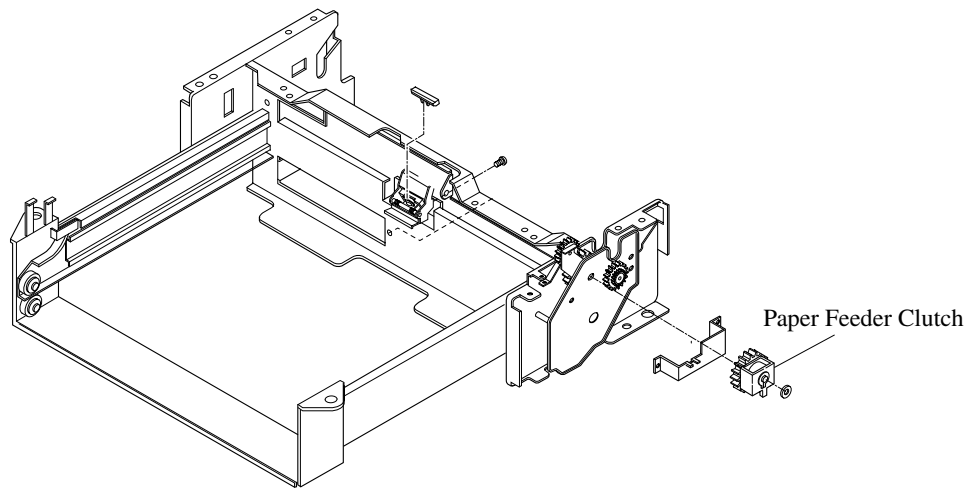

Fig. 7-111

7.9.3.3 Assembly Procedures

1. Install the paper transportation clutch.
2. Install the paper feeder clutch.
3. Reassemble in reverse order of disassembly.

7.9.4 Paper Feeder Roller / Separator Pad

7.9.4.1 Tool

#1 Phillips Screwdriver

7.9.4.2 Disassembly Procedures

(see Fig. 7-112)

1. Remove the left and right side covers (see section 7.9.3[1] and see section 7.9.3[2]).
2. Remove the LFU back door.
3. Remove the LFU paper guide by removing four set screws (ST3x6).
4. Remove the paper guide assembly by removing one set screw (ST3x6).
5. Sliding the Paper Feeder Roller along the shaft, remove the Paper Feeder Roller.
6. Remove the Separator Pad.

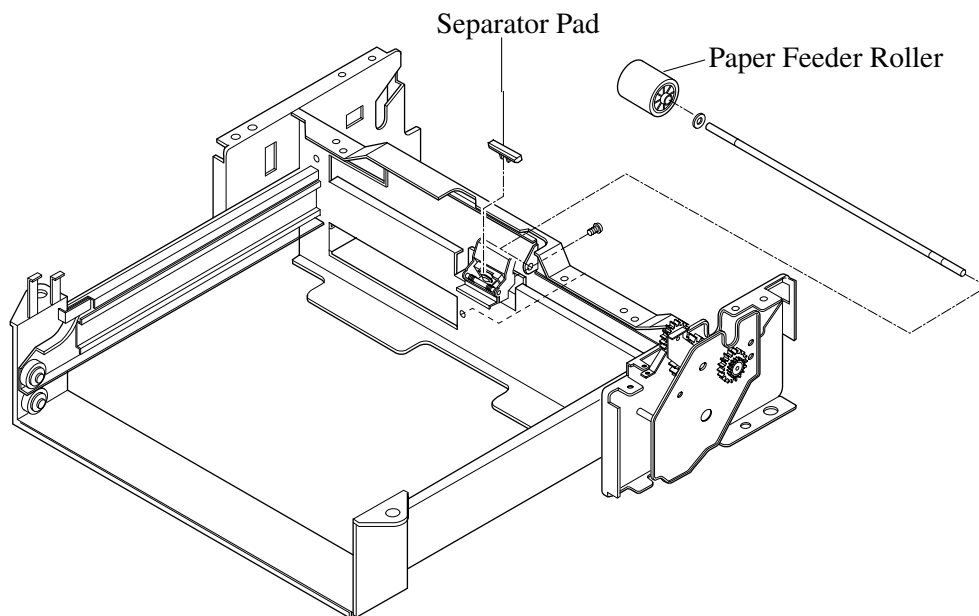

Fig. 7-112

7.9.4.3 Assembly Procedures

1. Install the new Separator Pad.
2. Install the new Paper Feeder Roller.
3. Reassemble in reverse order of disassembly.

7.9.5 Interlock Switches

7.9.5.1 Tool

#1 Phillips Screwdriver

7.9.5.2 Disassembly Procedures

(see Fig. 7-113)

1. Remove the LFU back door.
2. Remove the LFU paper guide by removing four set screws (ST3x6).
3. Disconnect the switch connector.
4. Remove the switch by removing one set screw (ST3x16).

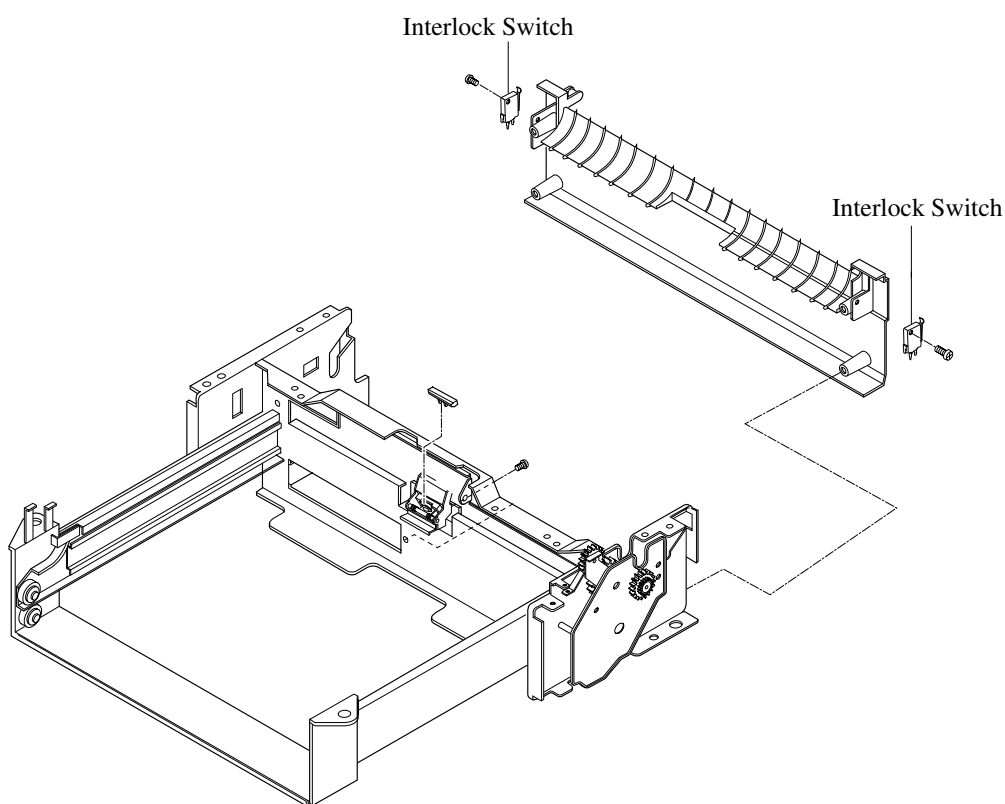

Fig. 7-113

7.9.5.3 Assembly Procedures

1. Reassemble in reverse order of disassembly.

7.9.6 IOD3 P.W.B. Assembly

7.9.6.1 Tool

#1 Phillips Screwdriver

7.9.6.2 Disassembly Procedures

(see Fig. 7-114)

1. Remove the LFU from the printer.
2. Remove the left base cover (see section 7.9.3[6]).
3. Disconnect five connectors from the IOD3 P.W.B. assembly.
4. Remove the IOD3 P.W.B. Assembly by removing four set screws (ST3x6).

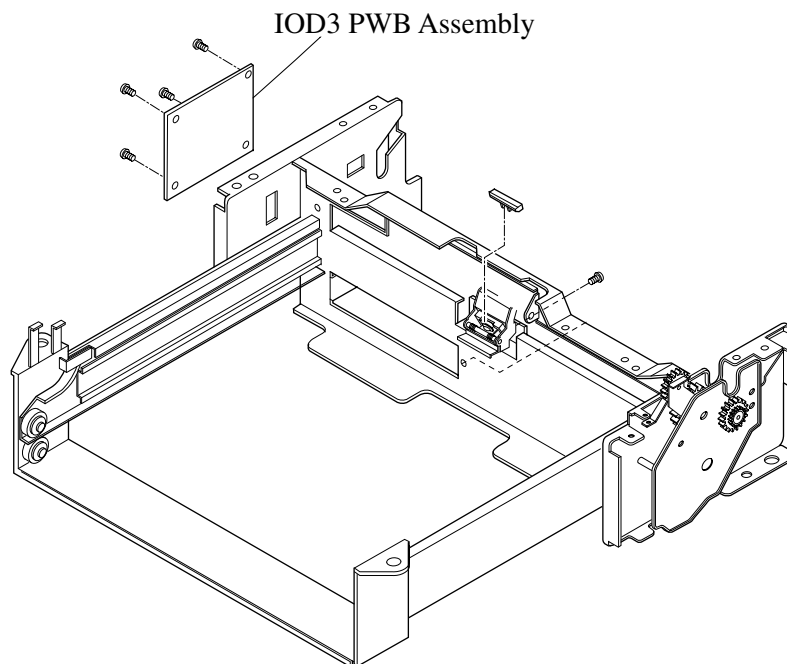

Fig. 7-114

7.9.6.3 Assembly Procedures

1. Reassemble in reverse order of disassembly.

Section 8:
Troubleshooting

8.0 Troubleshooting

8.1 Troubleshooting Outline

Review the troubleshooting flowchart (see Fig. 8-1) to determine which troubleshooting section should be used to solve printer errors and/or failures. Locate and follow the applicable flow charts (see Figs. 8-2 to 8-16) for full resolution procedures.

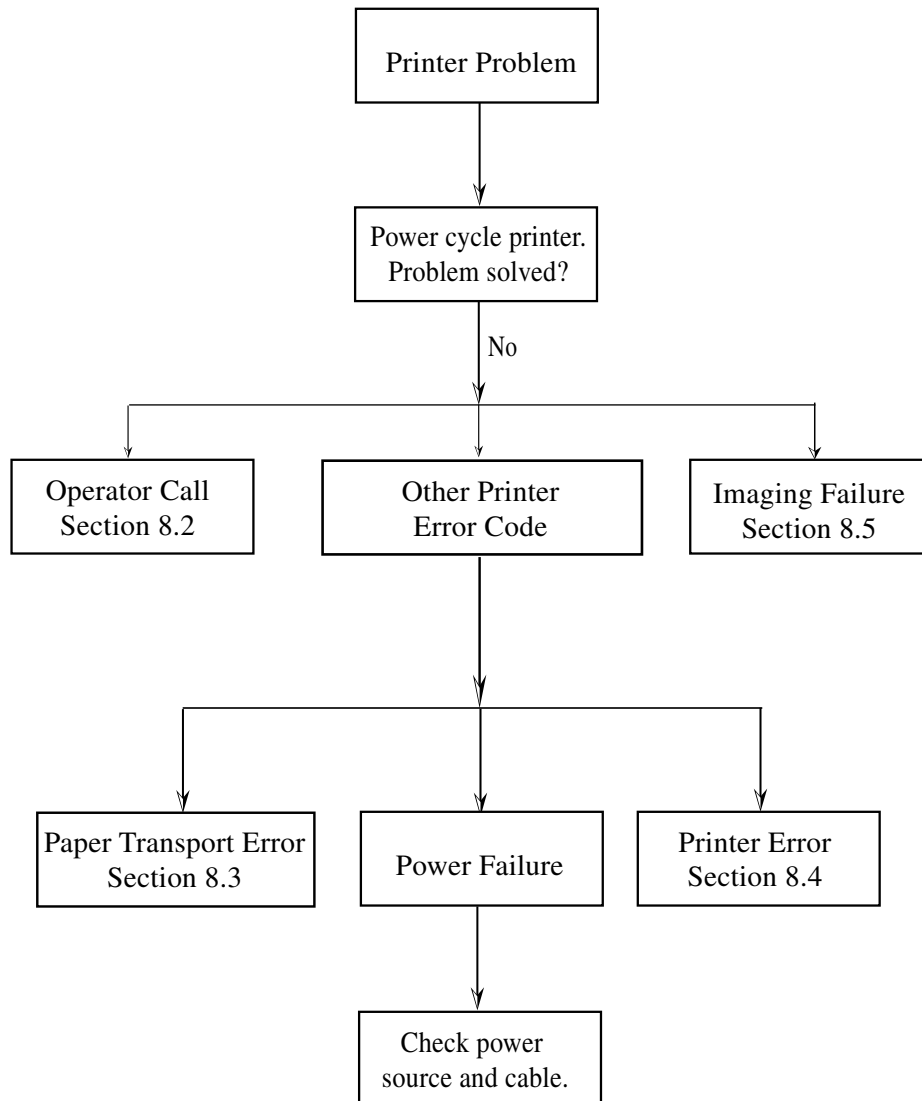

Fig. 8-1

8.2 Operator Call Error Codes

8.2.1 Standard Operator Call Error Resolutions

When the message LED is on and messages found in this section appear in the display, the countermeasures identified in Table 8-1 will usually resolve the problem.

If the operator call error code is not cleared by the noted countermeasure, proceed to Section 8.2.2, "Troubleshooting Flowcharts for Operator Call Error Codes."

Table 8-1

Message Display	Message Explanation	Countermeasure
PUT "SIZE" PAPER IN ANY BIN	Operator Control/Chain Inputbins is set to On and chained cassette is empty.	Refill the cassette with the specified size media.
PUT "SIZE" PAPER IN "INPUTBIN" BIN	The Operator Control/Chain Inputbins is set to Off and the displayed cassette is empty.	
PUT "SPECIAL MEDIA" IN UPPER BIN	Special media (e.g., transparency, thick stock, etc.) has been specified in the Operator Control/Media/For Upper Bin control panel setting. This message may direct the user to put the noted media in "ANY" bin.	Refill the cassette with thick stock or change the control panel setting from Thick Stock to Automatic.
ADJUST "INPUTBIN" BIN	The specified cassette is not inserted correctly or is missing.	Adjust or install the cassette.
OUTPUT BIN FULL	The media has exceeded the limit (such as over 250 sheets of 20lb [75 g/m ²] bond) in the output bin.	Remove the media from the output bin.
x TONER EMPTY	The x (color) toner cartridge is empty.	Replace the toner cartridge.
x TONER LOW	The x (color) toner is low. There is enough toner left to print approximately 100 pages before the printer stops.	Redistribute the toner in the cartridge, or replace the cartridge.

Table 8-1

Message Display	Message Explanation	Countermeasure
CHECK WASTE TONER	Either the waste toner pack is full and needs to be replaced, or it is incorrectly installed.	Ensure that the waste toner pack is not full and is correctly installed.
FUSER OIL EMPTY	The oil bottle for the fuser is empty. The printer will not print any more copies until a new oil bottle is installed.	Install a new fuser oil bottle.
FUSER OIL LOW	The oil bottle for the fuser unit is running low.	Fuser oil is running low. A limited number of copies (about 100) will still print. However, when the oil runs out, the printer stops and the FUSER OIL EMPTY message appears.
CHECK CLEANING ROLLER	The cleaning roller needs to be replaced.	Install a new cleaning roller.
x TONER MISINSTALLED	The x (color) toner cartridge is not installed properly.	Remove the toner cartridge and reinstall.
FUSER MISINSTALLED	The fuser is not fully seated.	Ensure the fuser is fully seated.
BELT CARTRIDGE MIS-INSTALLED	The OPC belt cartridge is either missing or incorrectly installed.	Ensure that an OPC belt cartridge is correctly installed.
CLEANING ROLLER MISINSTALLED	The fuser cleaning roller isn't installed correctly.	Remove and reinstall cleaning roller.
MISFEED JAM	Media has jammed between the print engine and the input cassette.	Locate and remove the jam.
INNER JAM	Media has jammed leaving the OPC belt cartridge area.	Locate and remove the jam.
OUTER JAM	Media has jammed between the print engine and the output tray.	Locate and remove the jam.
DRUM JAM	Media has jammed in the transfer drum area.	Locate and remove the jam.
DUPLEX JAM	Media has jammed in the duplexer.	Locate and remove the jam.

Table 8-1

Message Display	Message Explanation	Countermeasure
x DOOR OPEN	The noted door is open. Front Door, Top Door, Rear Door, Optional Bin Rear Door	Close the noted door.
DUPLEX UNIT PANEL OPEN	One of the duplexer doors is open.	Close the door.
ENERGY SAVER	The printer is in energy saver mode to reduce power consumption during periods of inactivity.	No action needed. These are normal operation modes.
WARMING UP	The printer is warming up.	
IDLE	The printer is on line, but no jobs are in process.	
INPUT IDLE PRINTING	The printer is on line and printing jobs already in the queue. No new jobs are arriving at the communication interfaces.	

8.2.2 Persistent Operator Call Error Code Resolutions

Normally, the operator call can be cleared by the performing the applicable countermeasures listed in Table 8-1. If not cleared, the printer engine may have a failure. Check and implement the appropriate countermeasures in accordance with the following procedures.

Note:

If you get persistent errors, reboot the printer in service mode and use the flow charts in this section to troubleshoot using the MCTL error codes. The MCTL error codes are found to the left of the controller codes in the first step of the flow charts.

Fig. Number	MCTL Code	Error Message
8-2	11	PUT 'SIZE' IN ANY BIN
8-3	11	CHECK MEDIA
8-4	11	NO MEDIA UPP/LF1/LF2
8-5	11	CHK MEDIA FOR DUPLEX
8-6	12	ADJUST 'n' BIN
8-7	12	OUTPUT BIN FULL
8-8	13	'X' TONER LOW/EMPTY
8-9	14	CHECK WASTE TONER
8-10	14	FUSER OIL LOW/EMPTY
8-11	14	CHECK CLEANING ROLLER
8-12	15	MISPRINT PAPER/NOPRQ/MEDIA/DUPLEX
8-13	16	ALIGN TONER CG Y/M/C/K
8-14	16	ALIGN FU UNIT
8-15	16	ALIGN BELT CG
8-16	16	ALIGN FUSER CL ROLLER
8-17	16	ALIGN TR ROLLER

Fig. Number	MCTL Code	Error Message
8-18	16	ALIGN LFU
8-19	17	MISFEED JAM
8-20	17	INNER JAM
8-21	17	OUTER JAM
8-22	17	DRUM JAM
8-23	17	DUPLEX JAM
8-24	18	CLOSE PANEL FRONT/TOP
8-25	18	REAR DOOR OPEN
8-26	18	DUPLEX UNIT PANEL OPEN

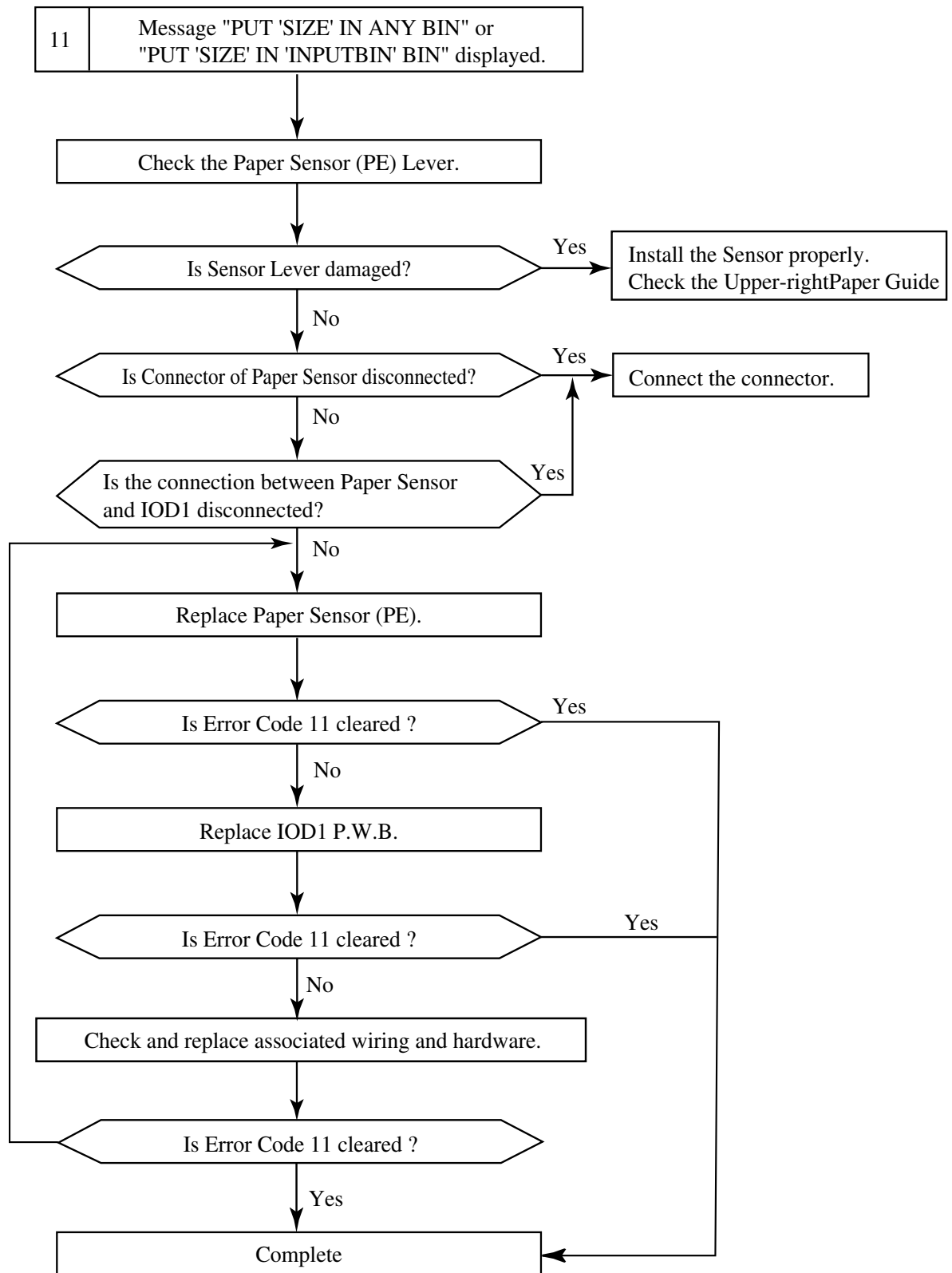
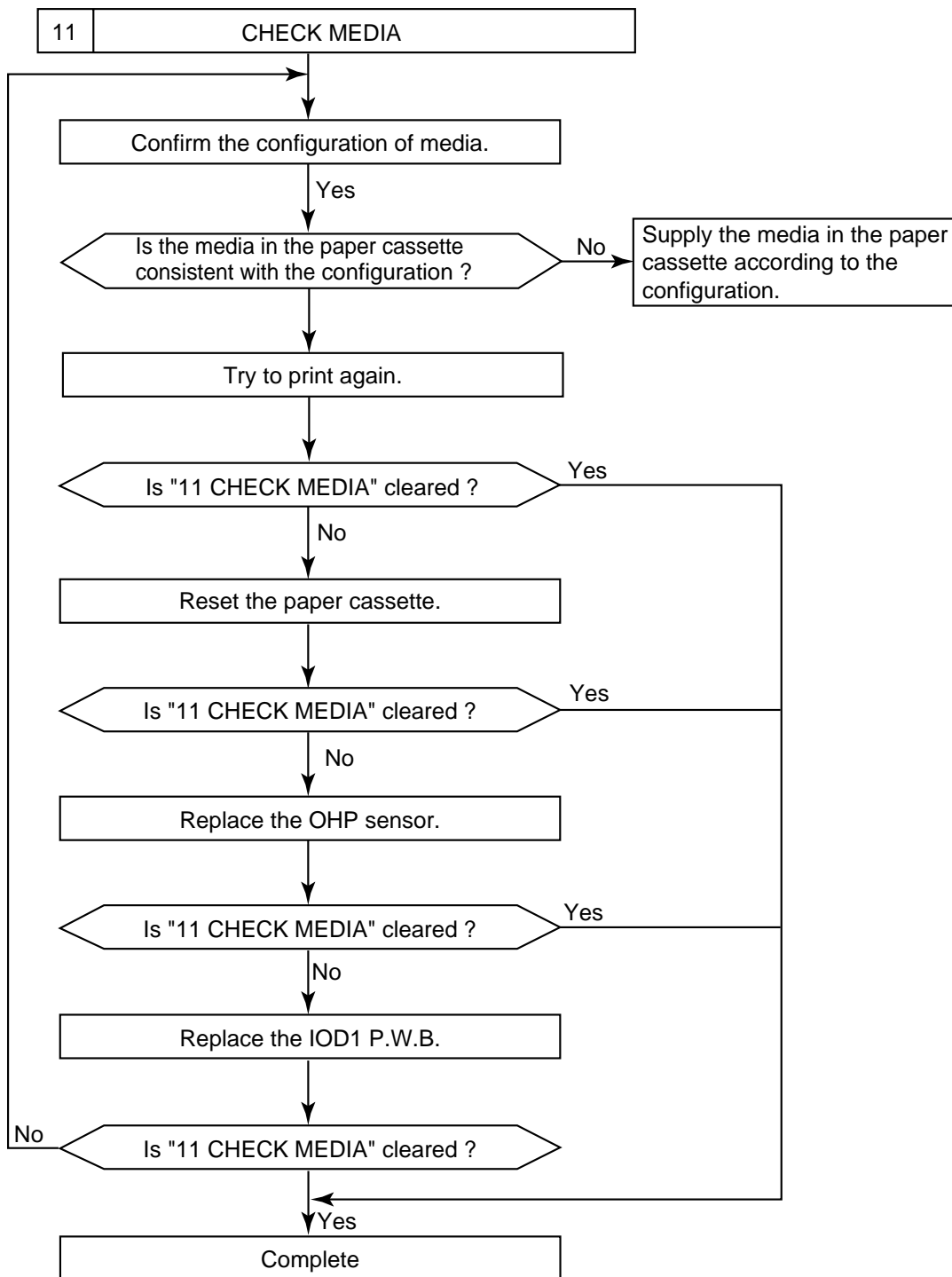

Fig. 8-2



Note

- OHP is not available from the lower paper cassette.
- If printing is carried out with the unavailable paper size, "CHECK MEDIA" appears. (For example, 2-UP print mode is set, but the configuration is A3 paper.)

Fig. 8-3

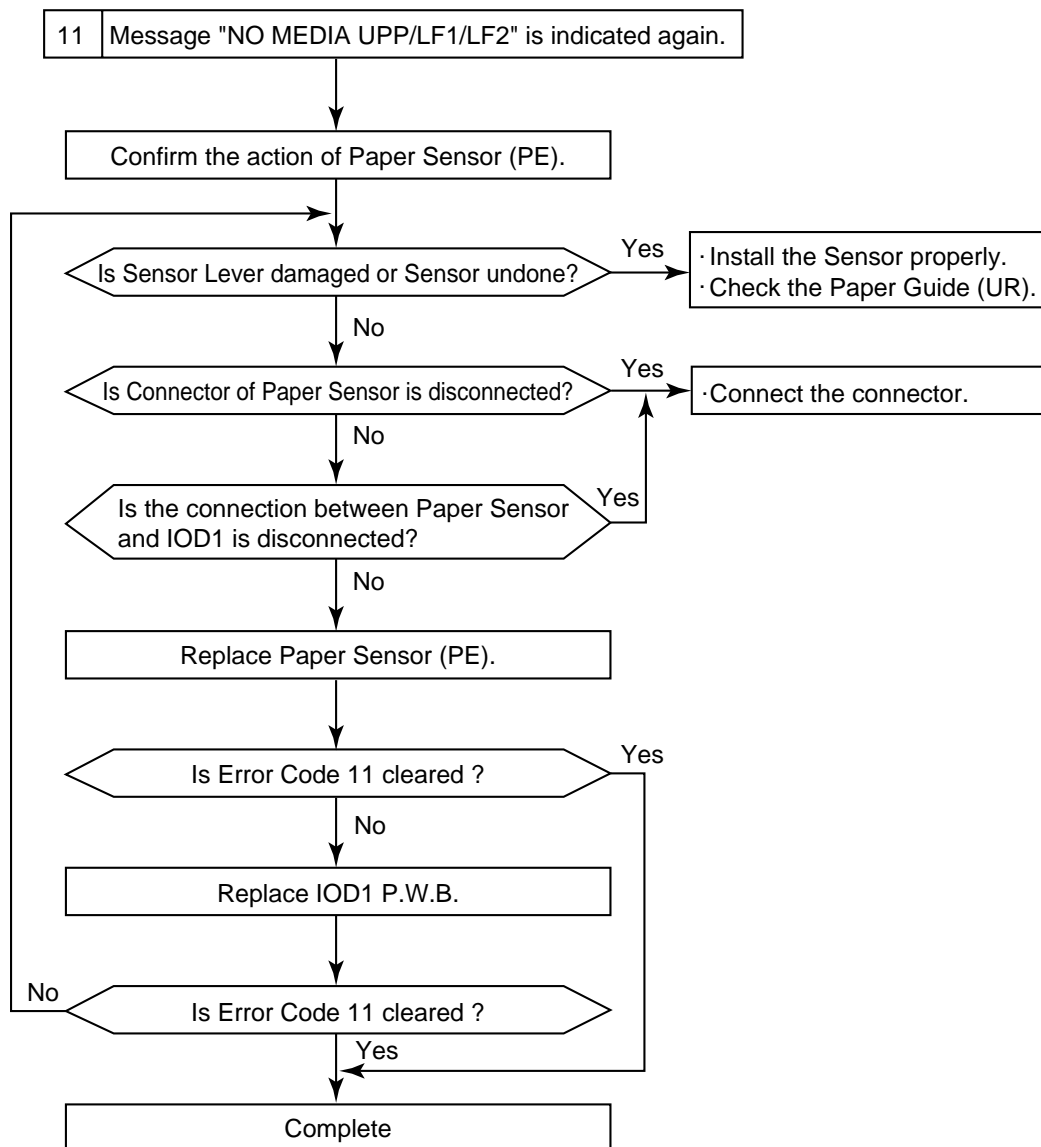

Note

UPP: Upper cassette
 LF1 : Lower (1) cassette
 LF2 : Lower (2) cassette

Fig. 8-4

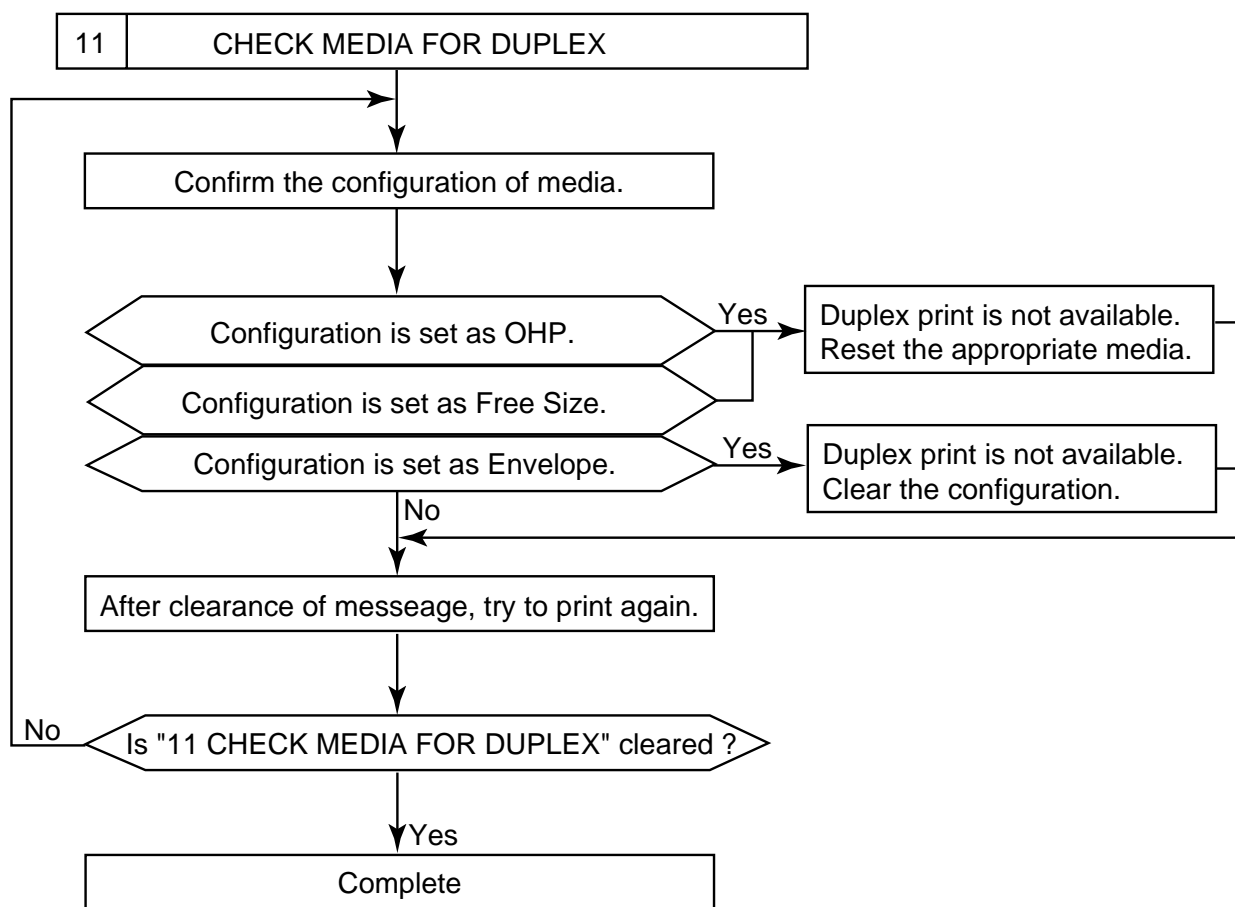

Note

- If the unprintable media (out of specification) is set for duplex print, "CHECK MEDIA FOR DUPLEX" appears.
- If the unprintable print mode (out of specification) is set, "CHECK MEDIA FOR DUPLEX" appears.
(For example, the configuration is set as Label Stock to be printed by High Speed Mode.)

Fig. 8-5

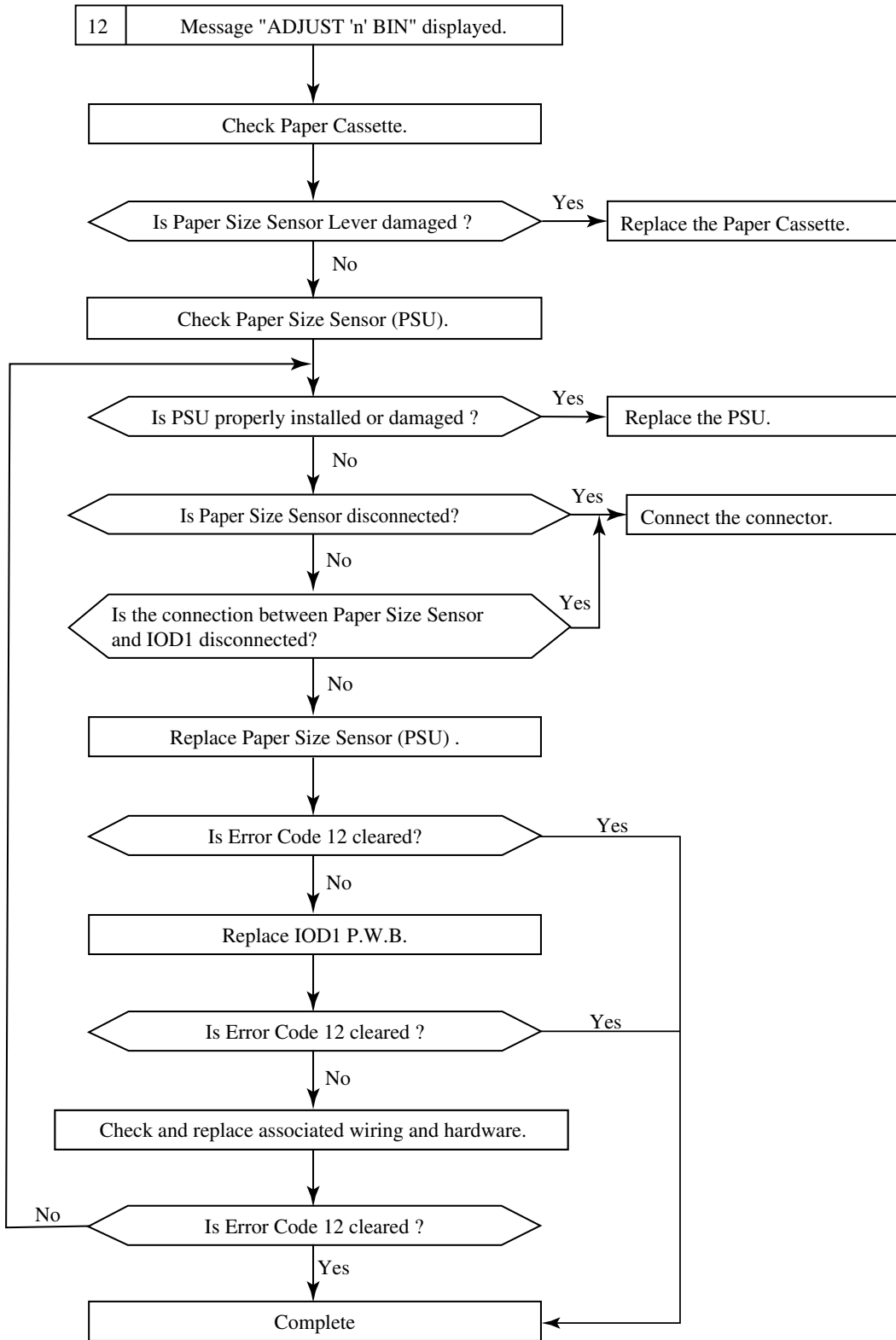

Fig. 8-6

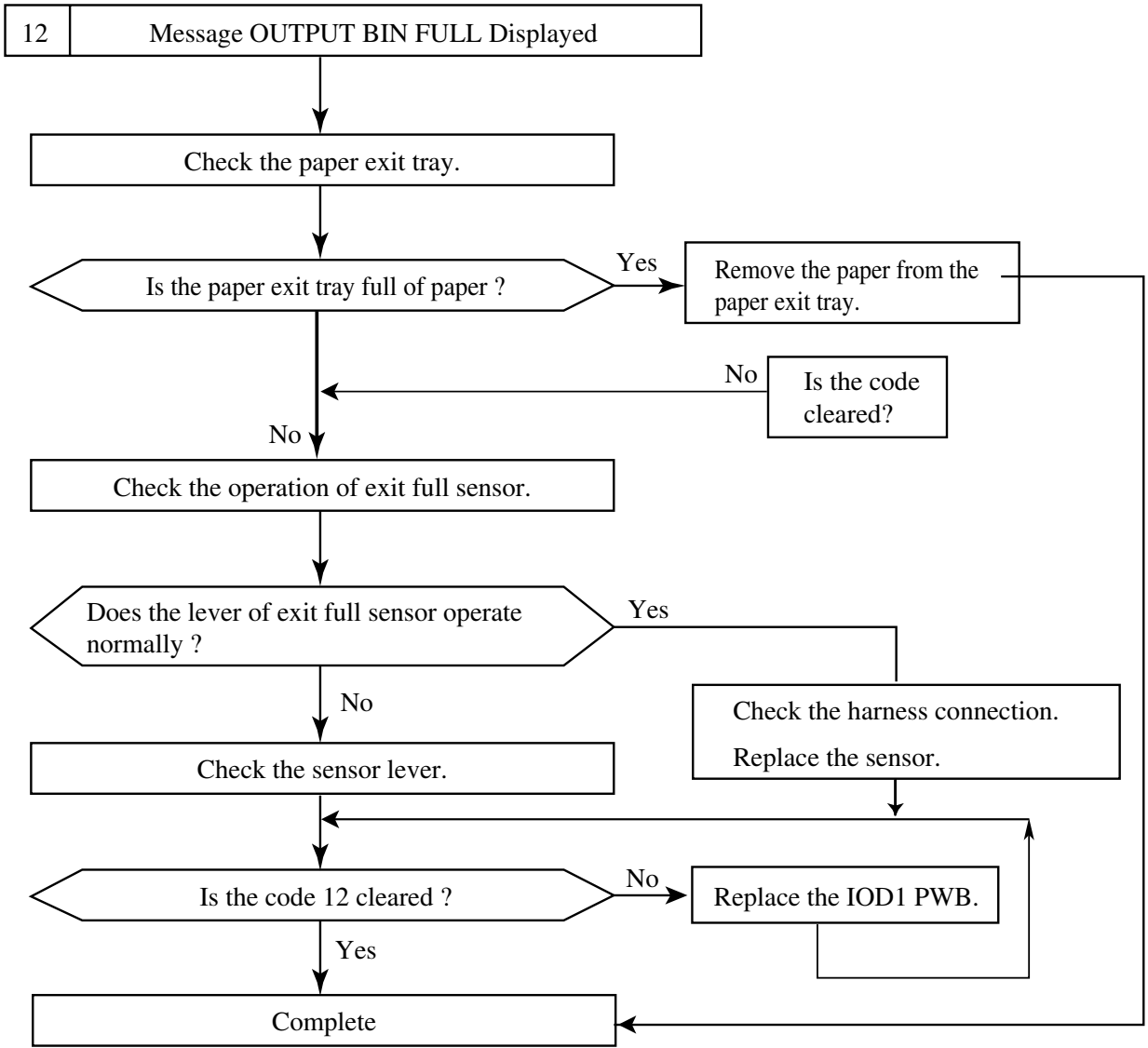

Fig. 8-7

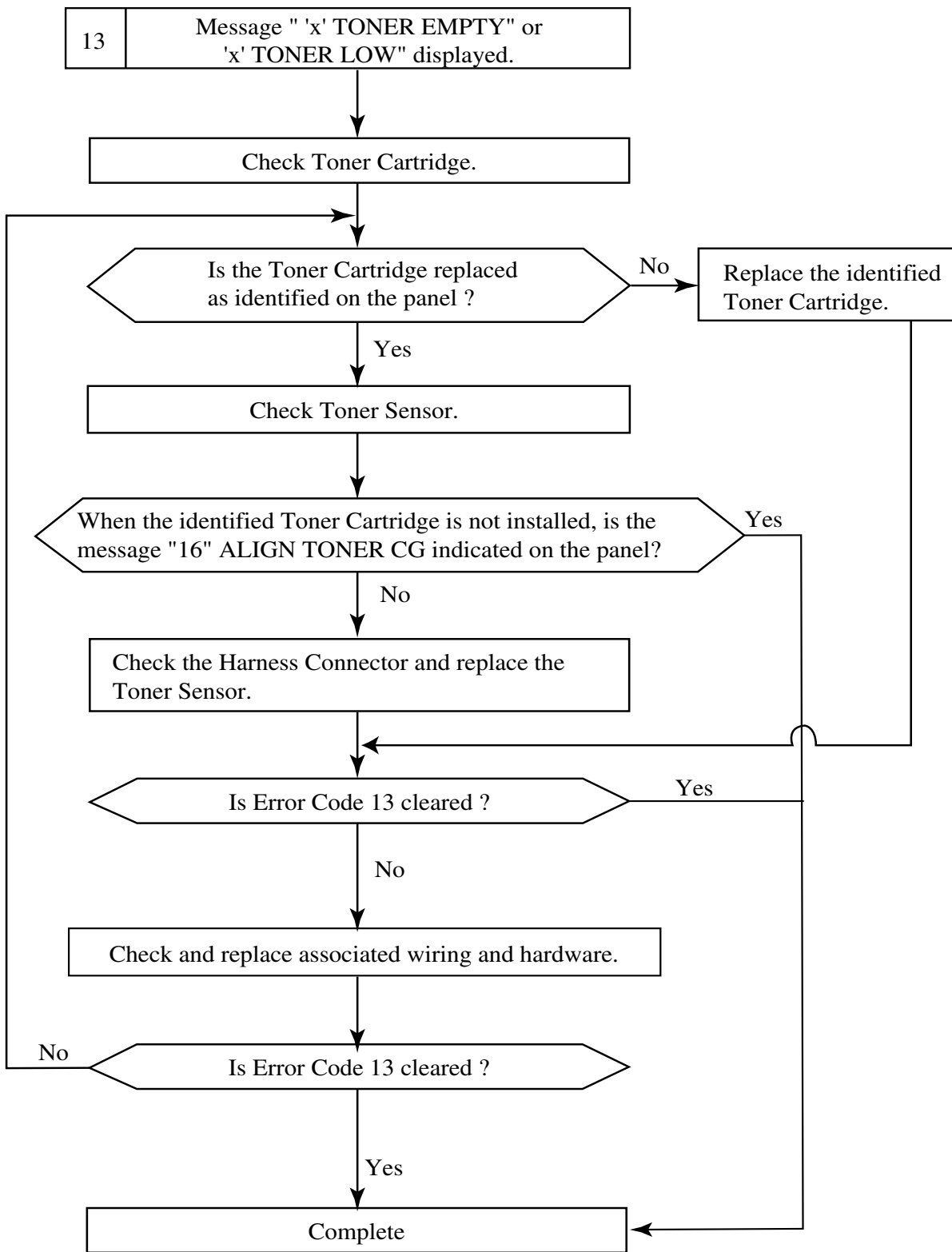

Fig. 8-8

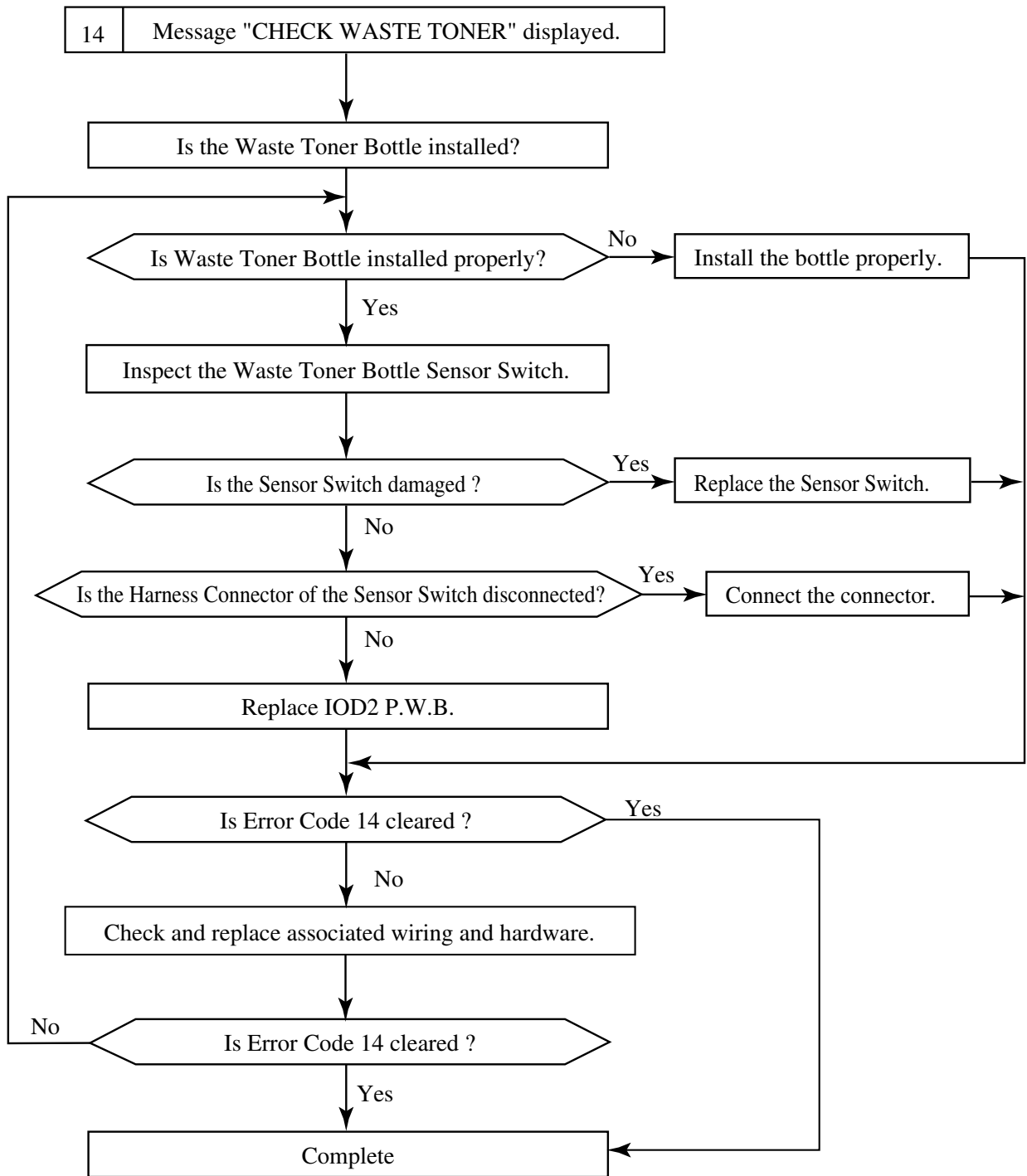

Fig. 8-9

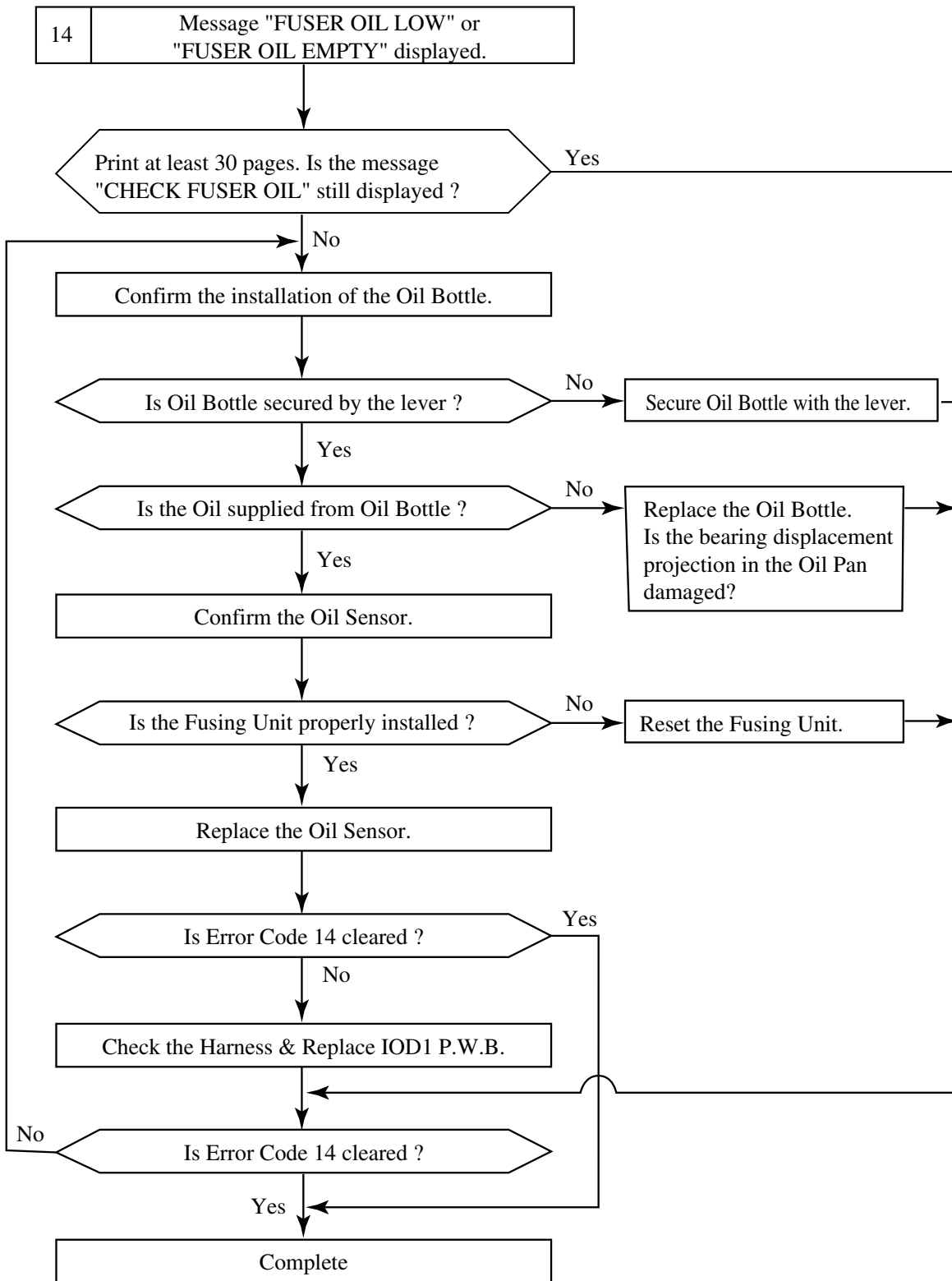

Fig. 8-10

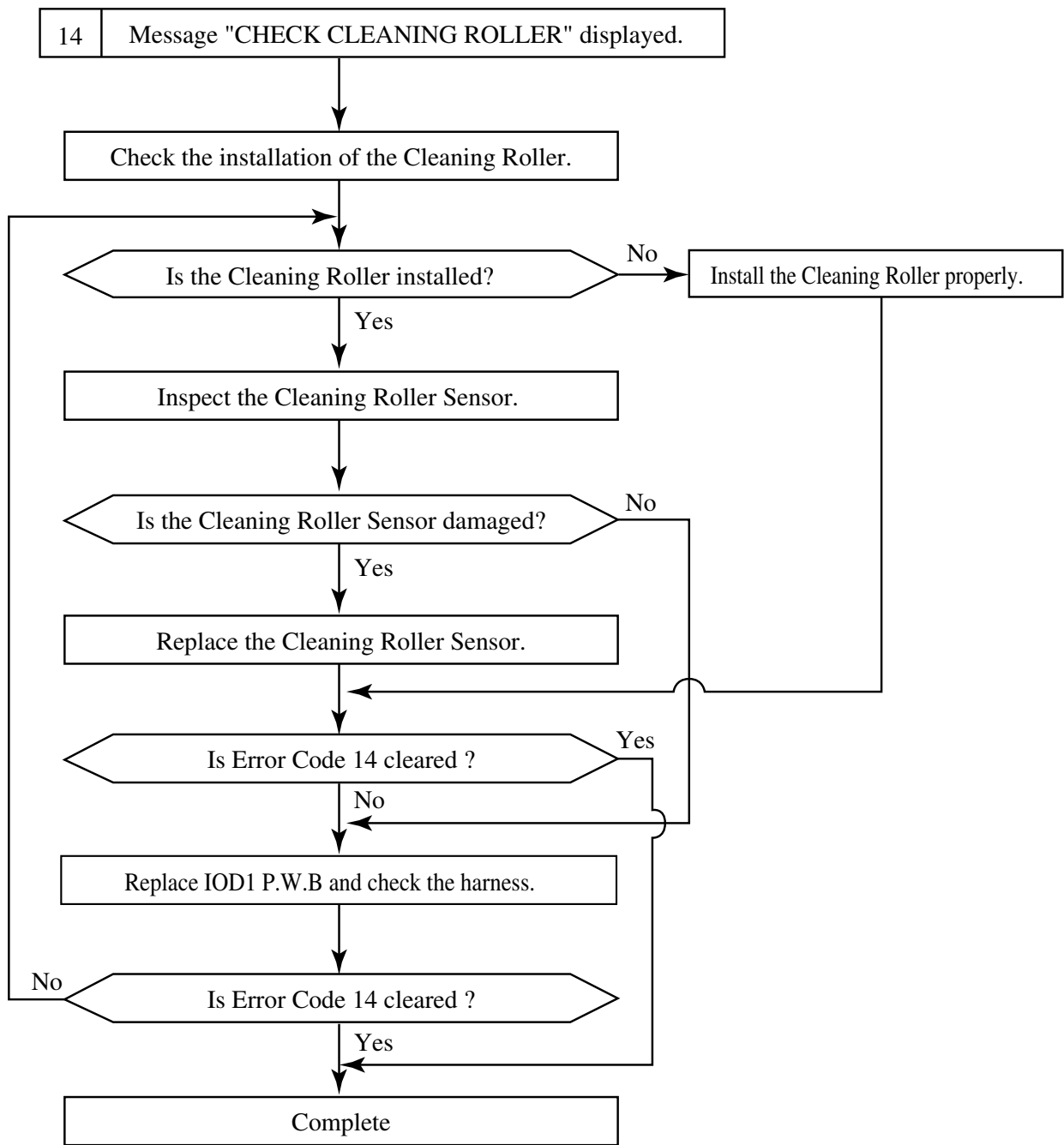
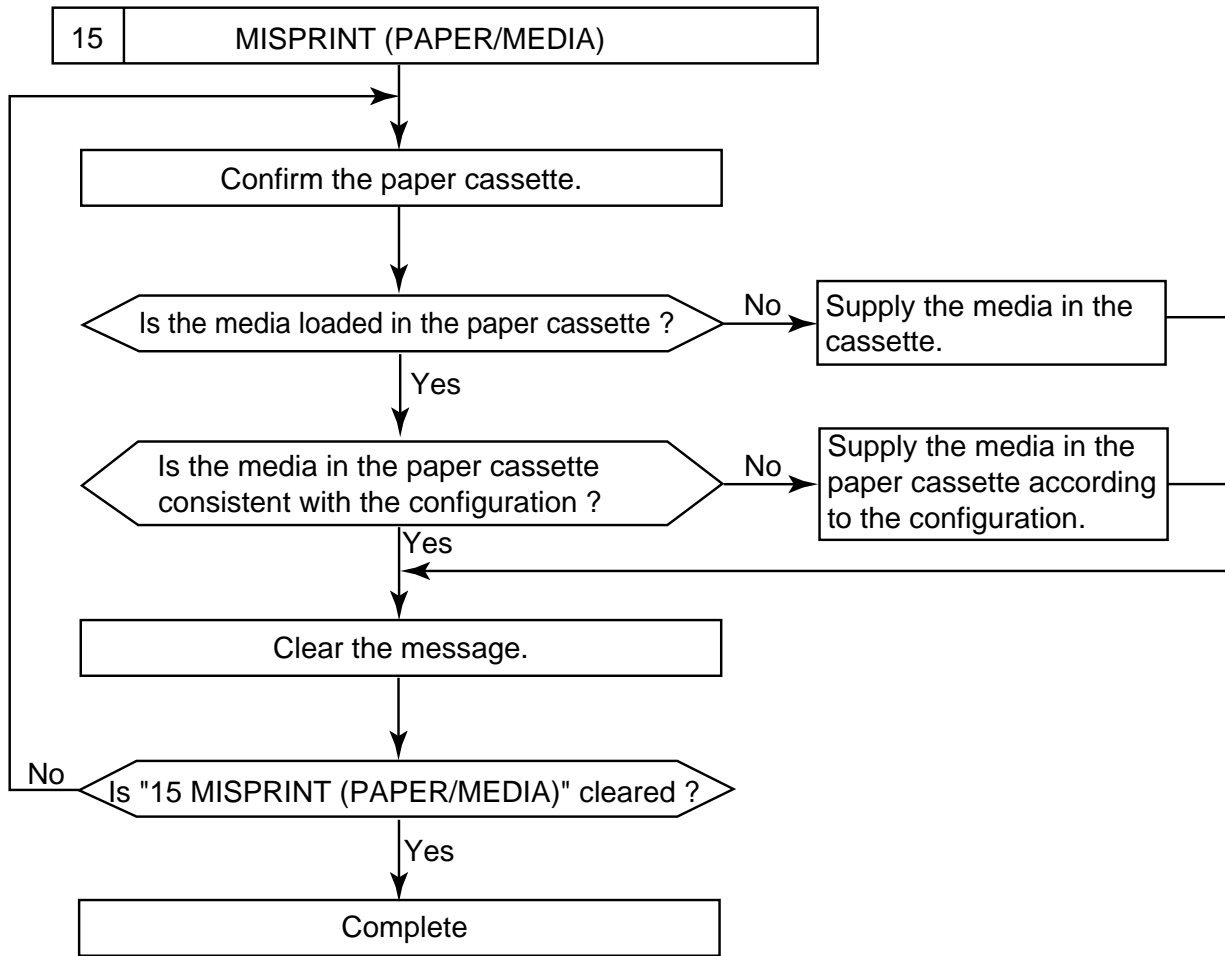

Fig. 8-11



Note

- If the paper runs out at the continuous print while the transmission of print data, "MISPRINT" appears.
- If different media are mixed in the paper cassette, "MISPRINT" appears.

Fig. 8-12

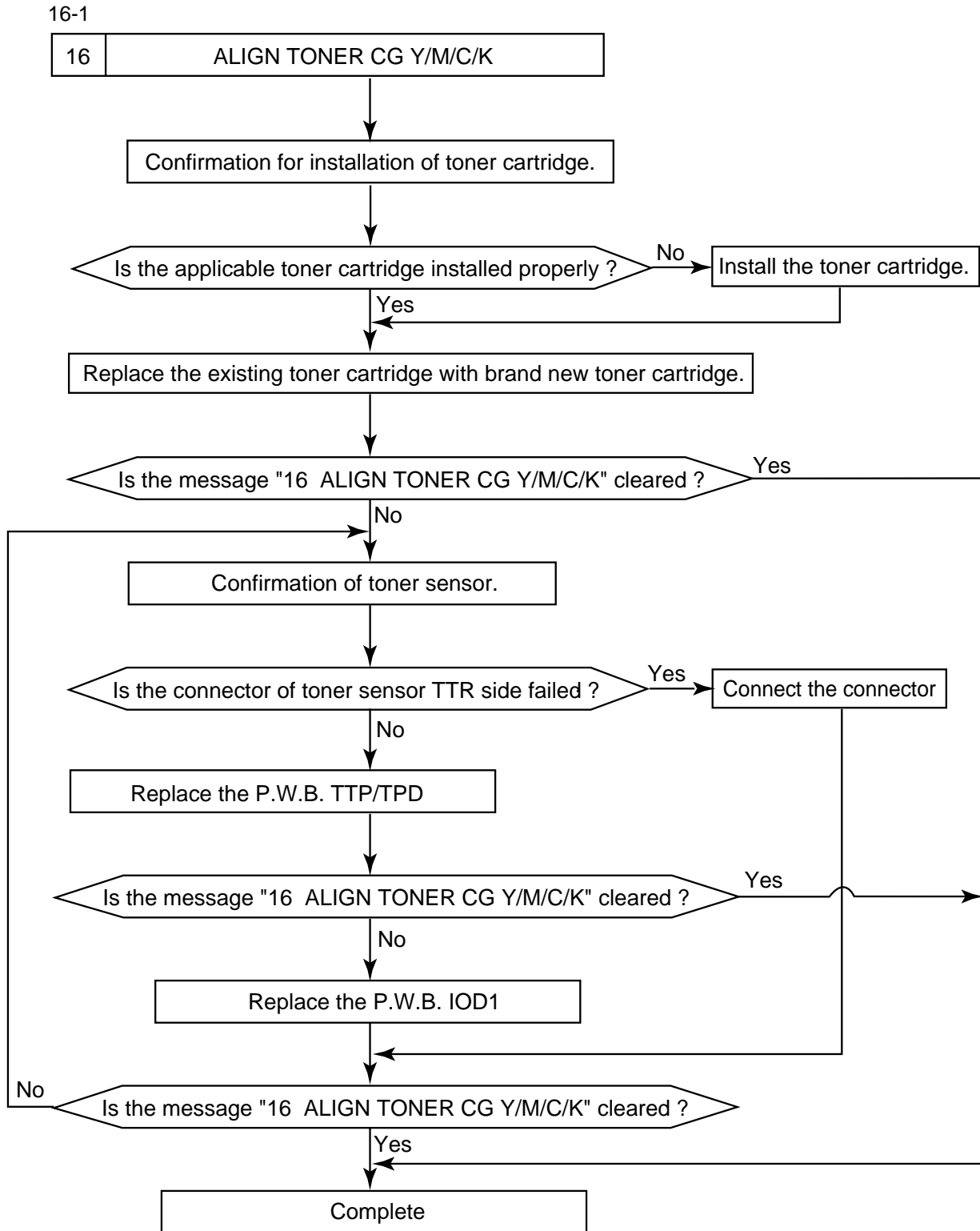

Fig. 8-13

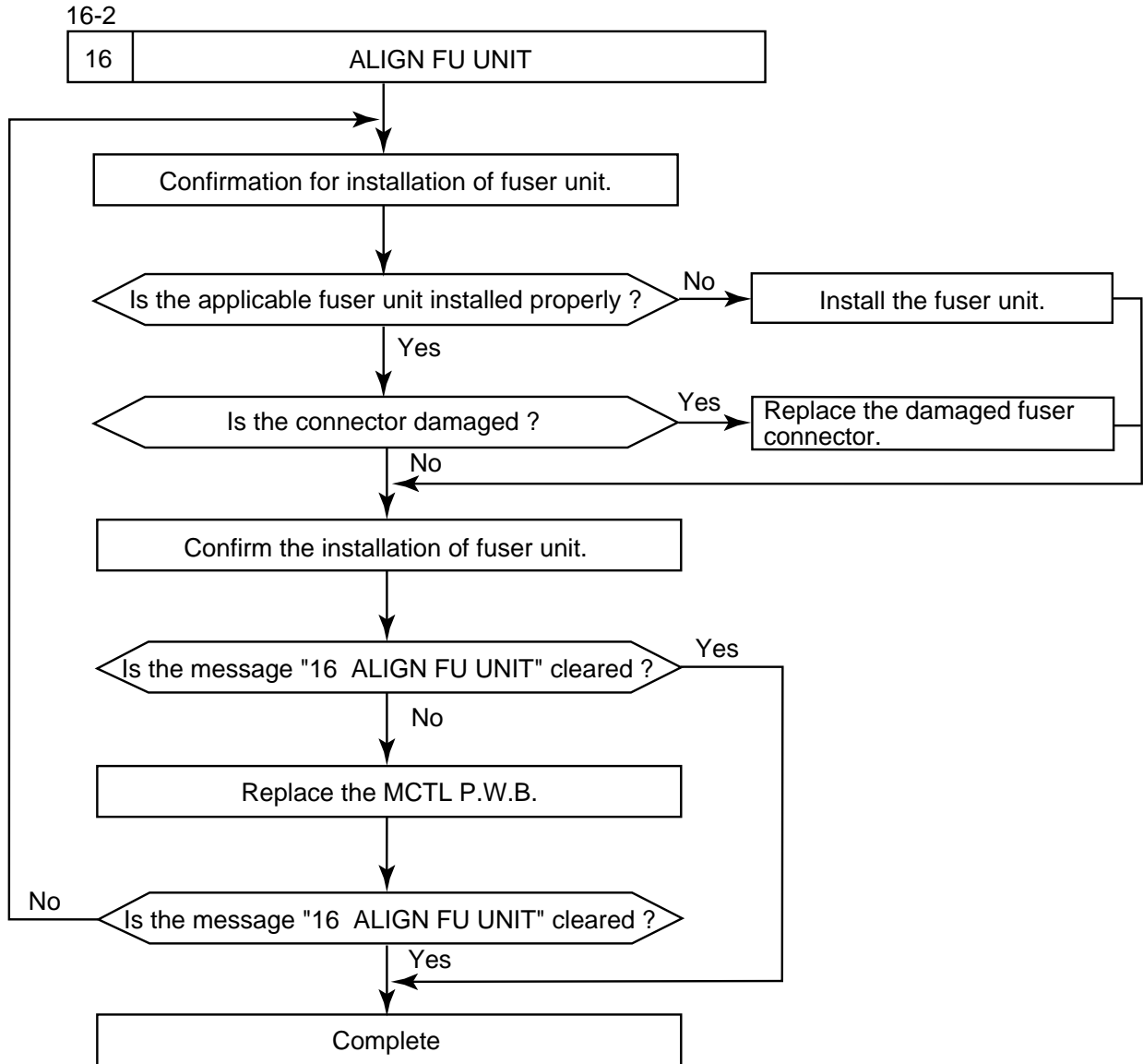

Fig. 8-14

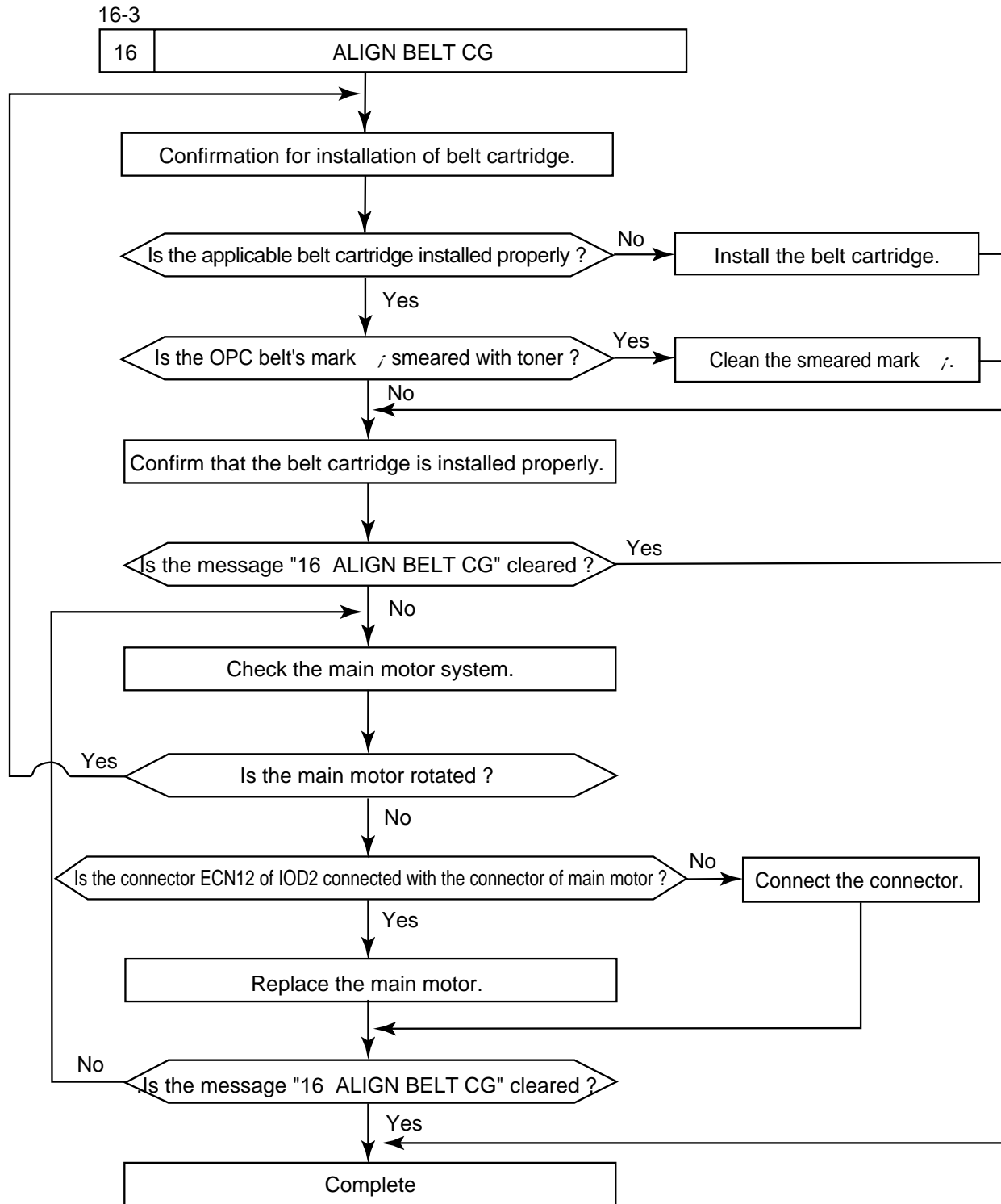

Fig. 8-15

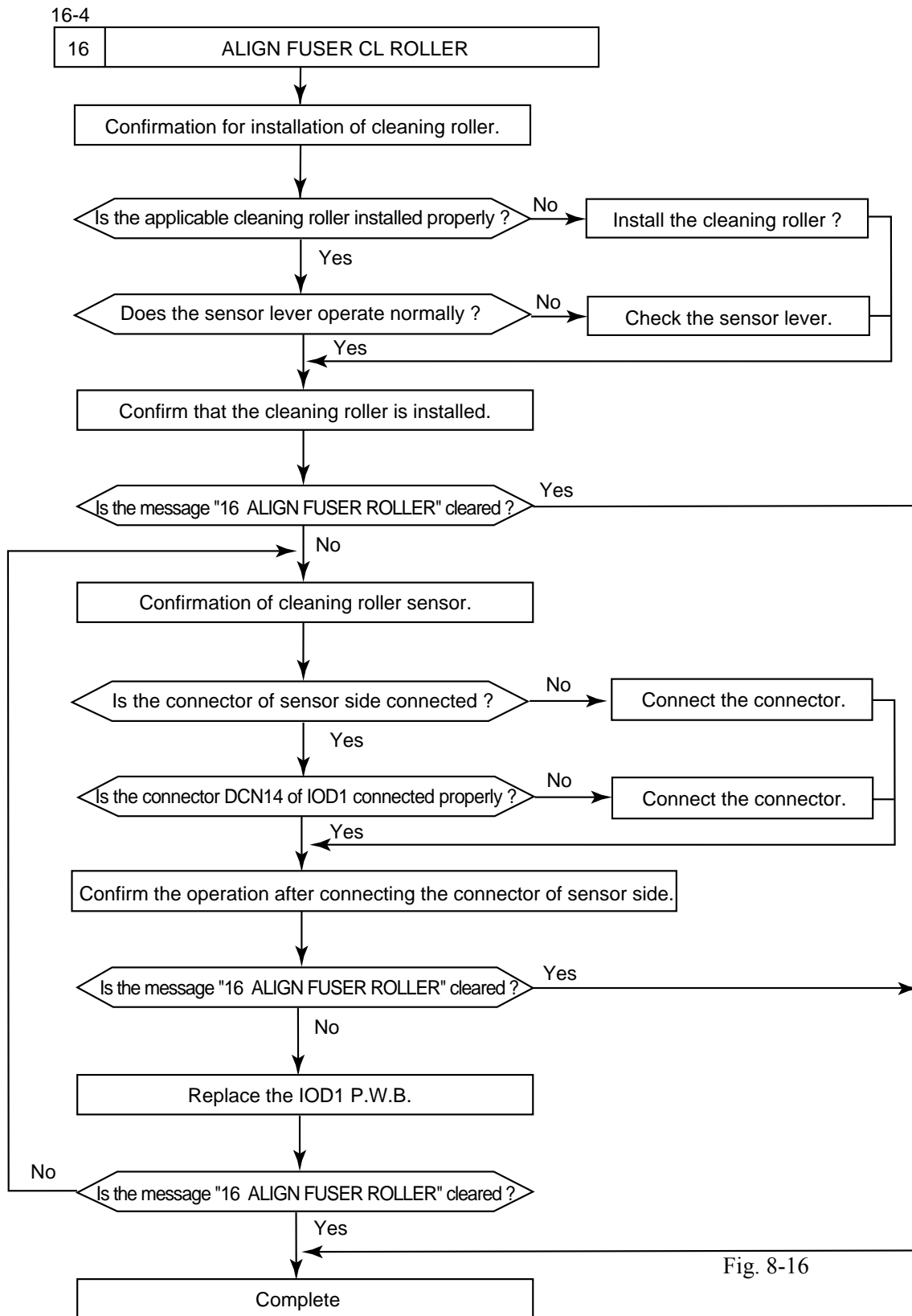

Fig. 8-16

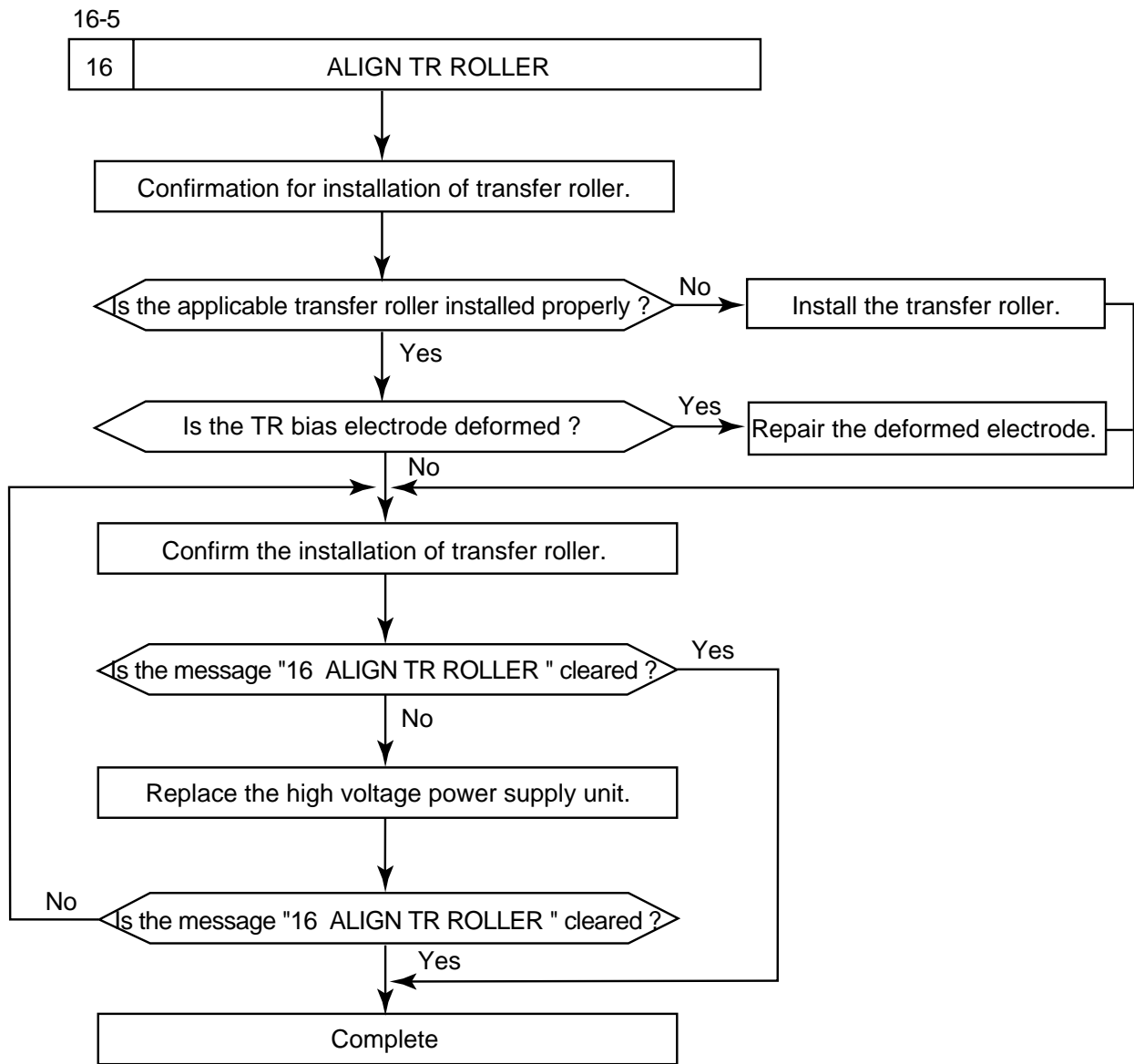

Fig. 8-17

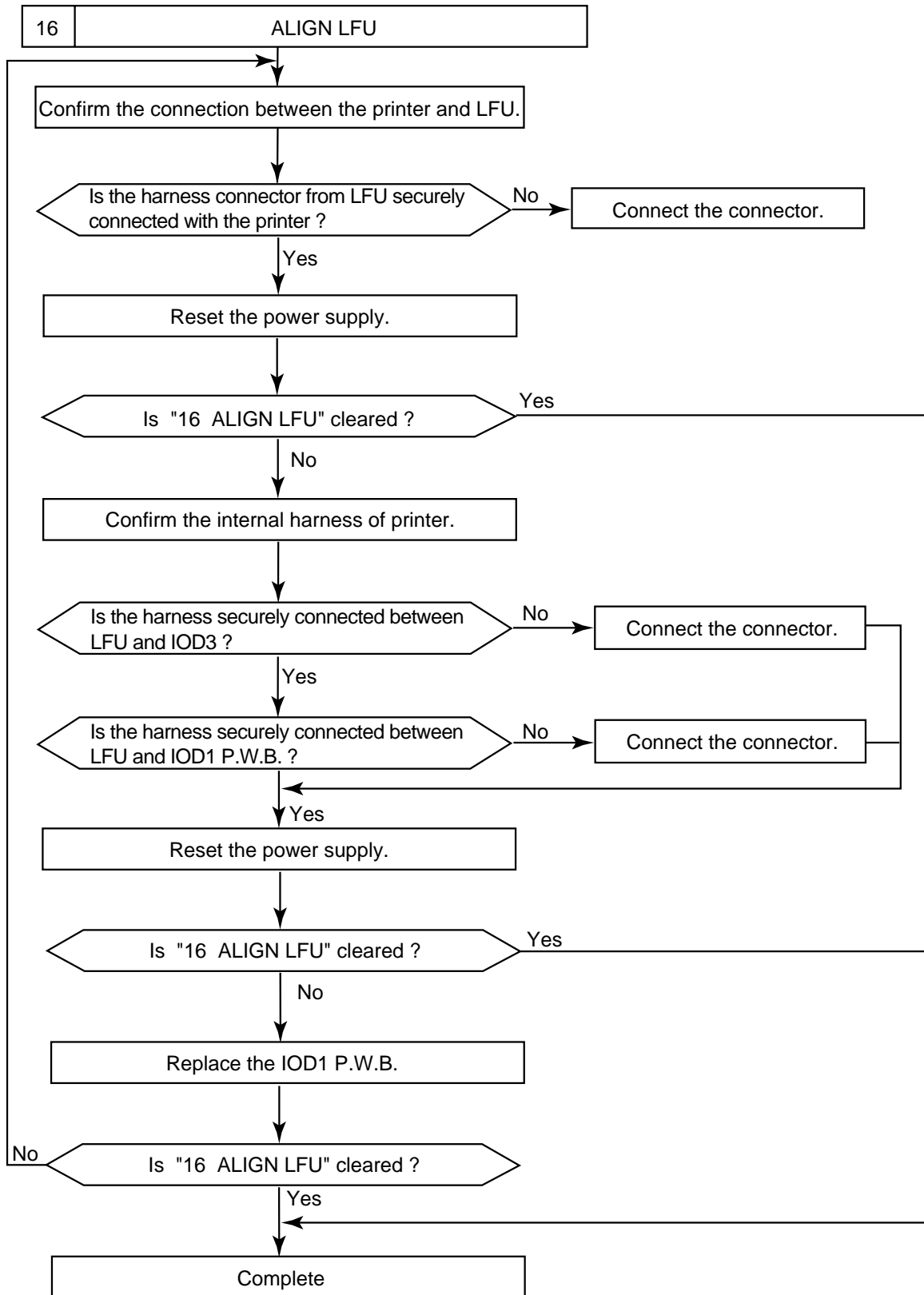

Fig. 8-18

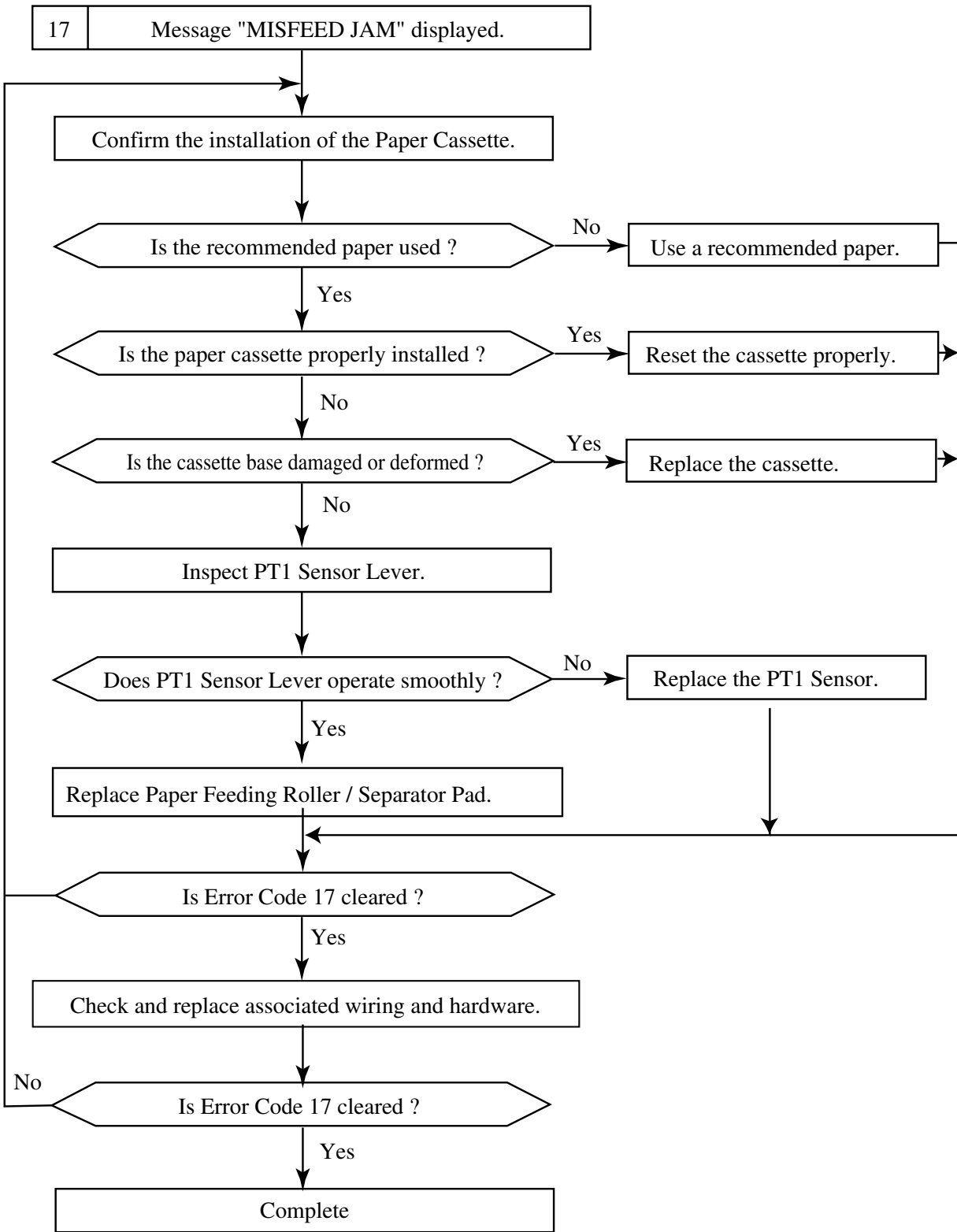

Fig.8-19

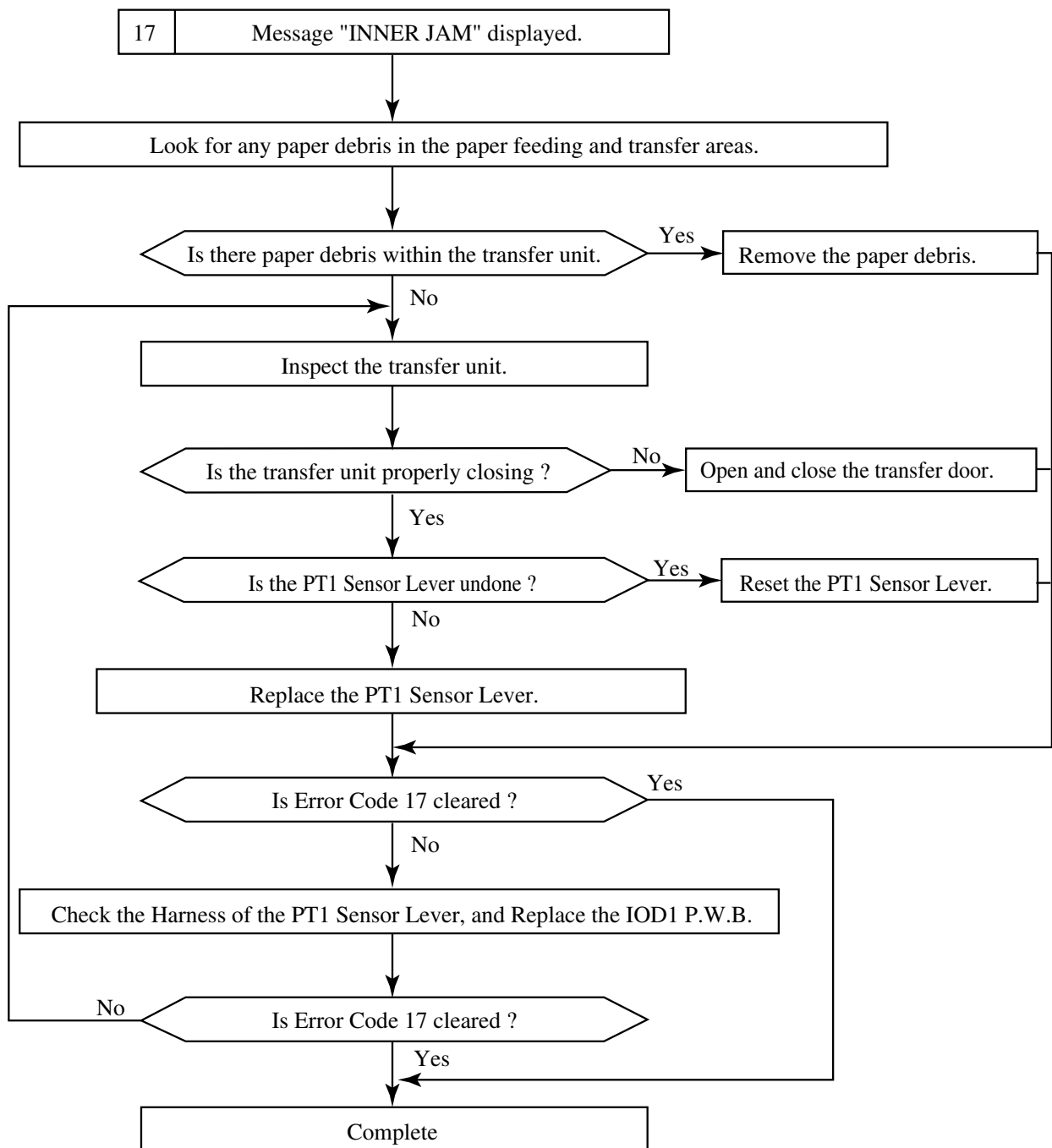

Fig. 8-20

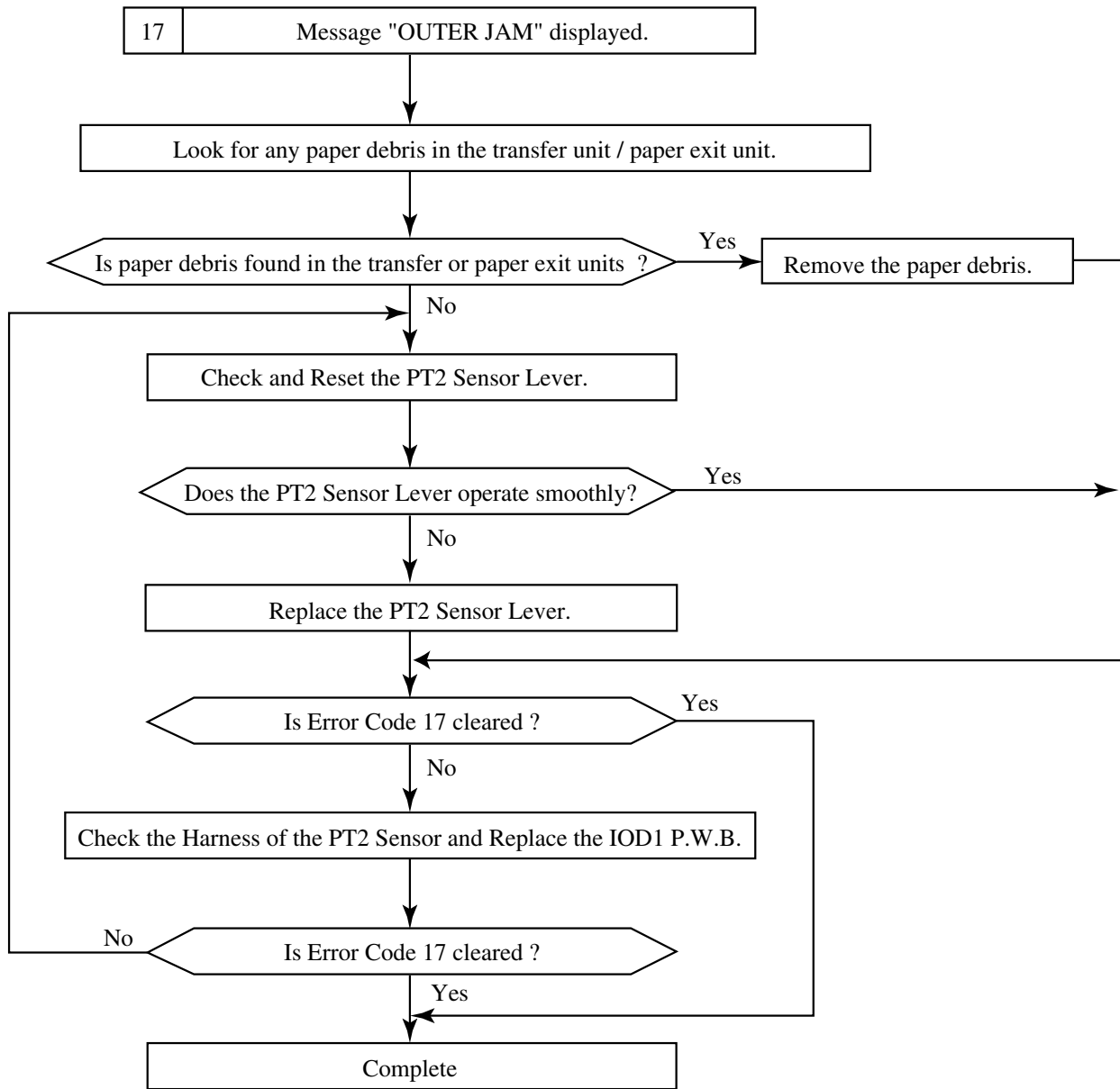

Fig. 8-21

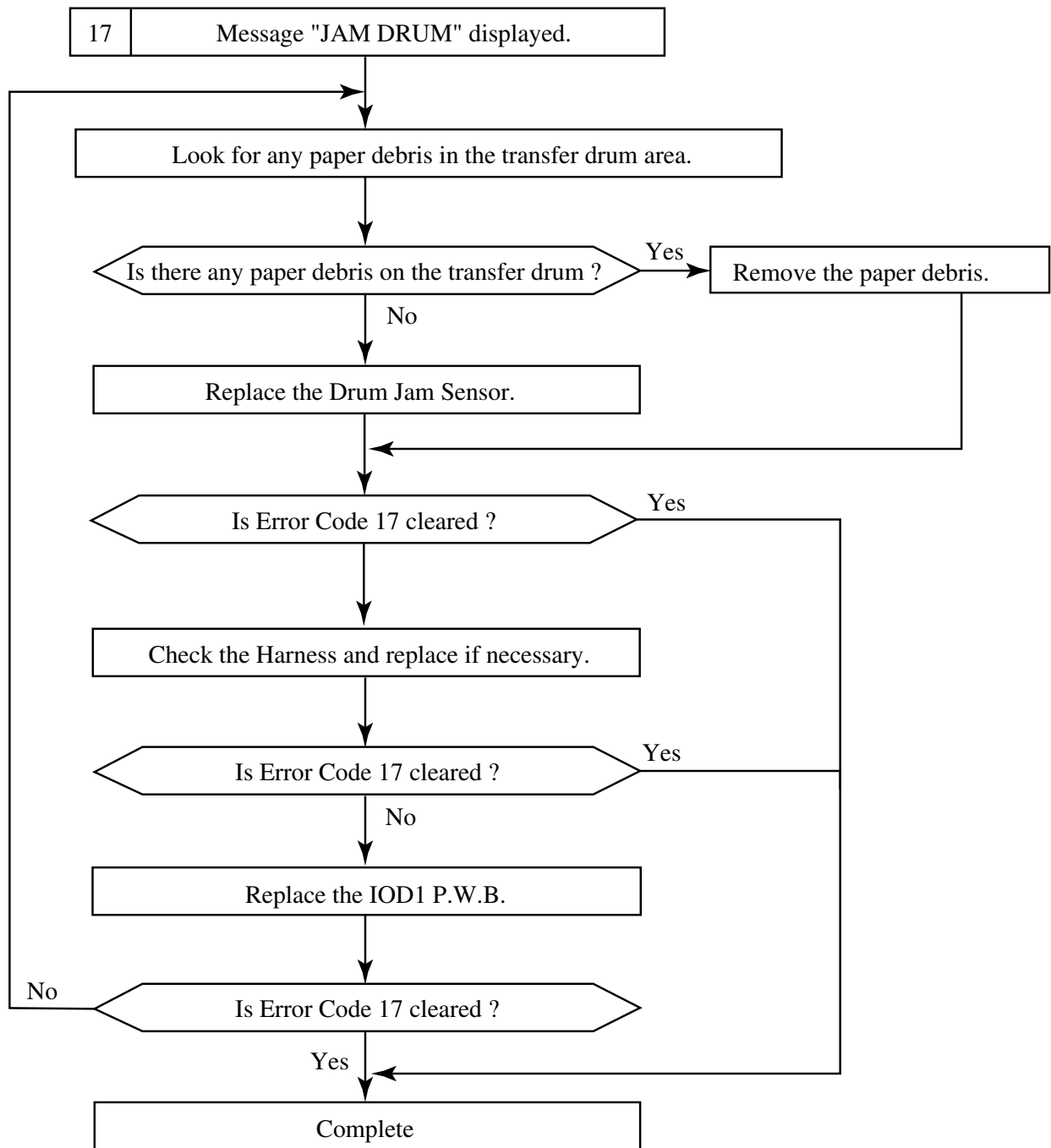

Fig. 8-22

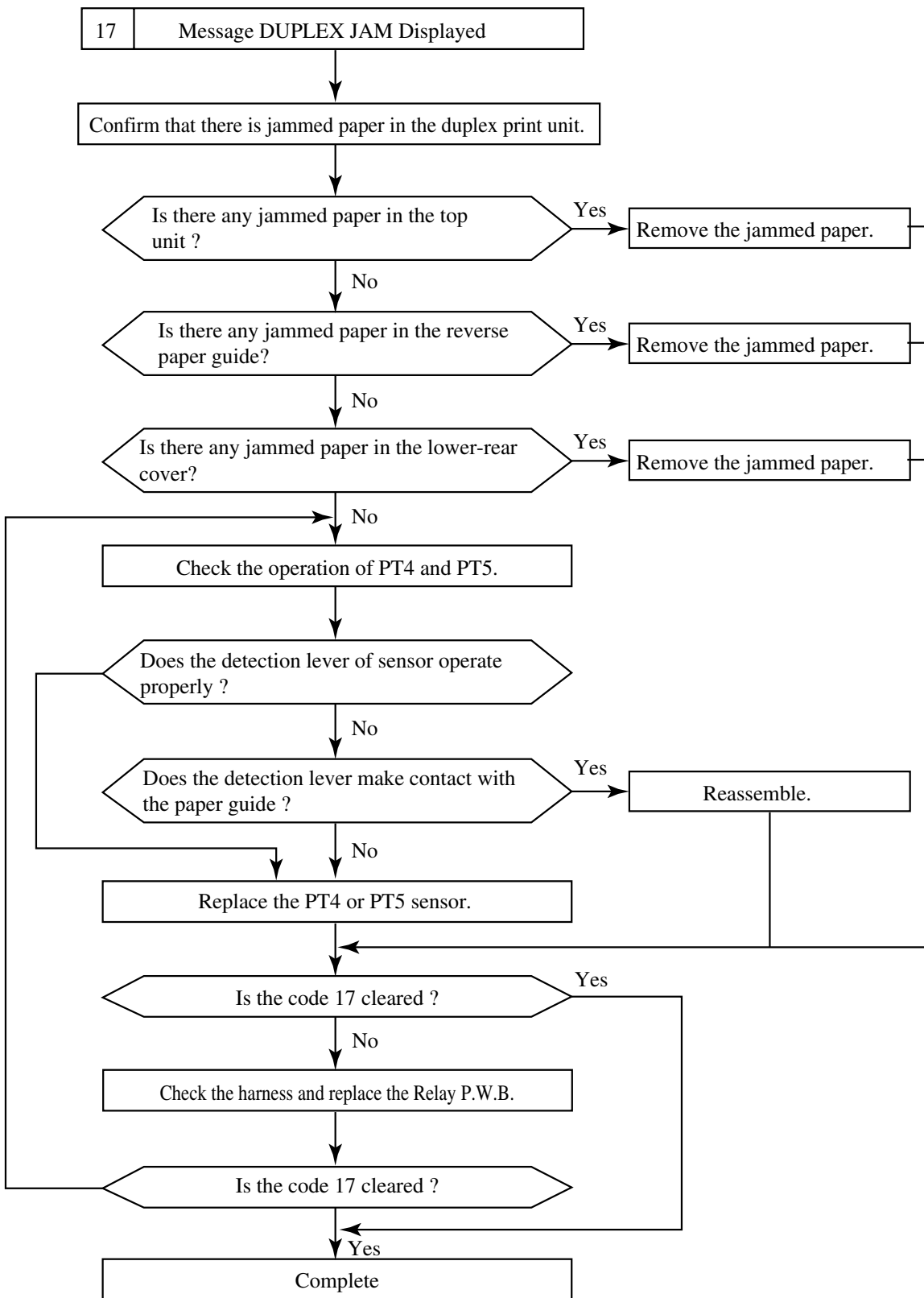

Fig.8-23

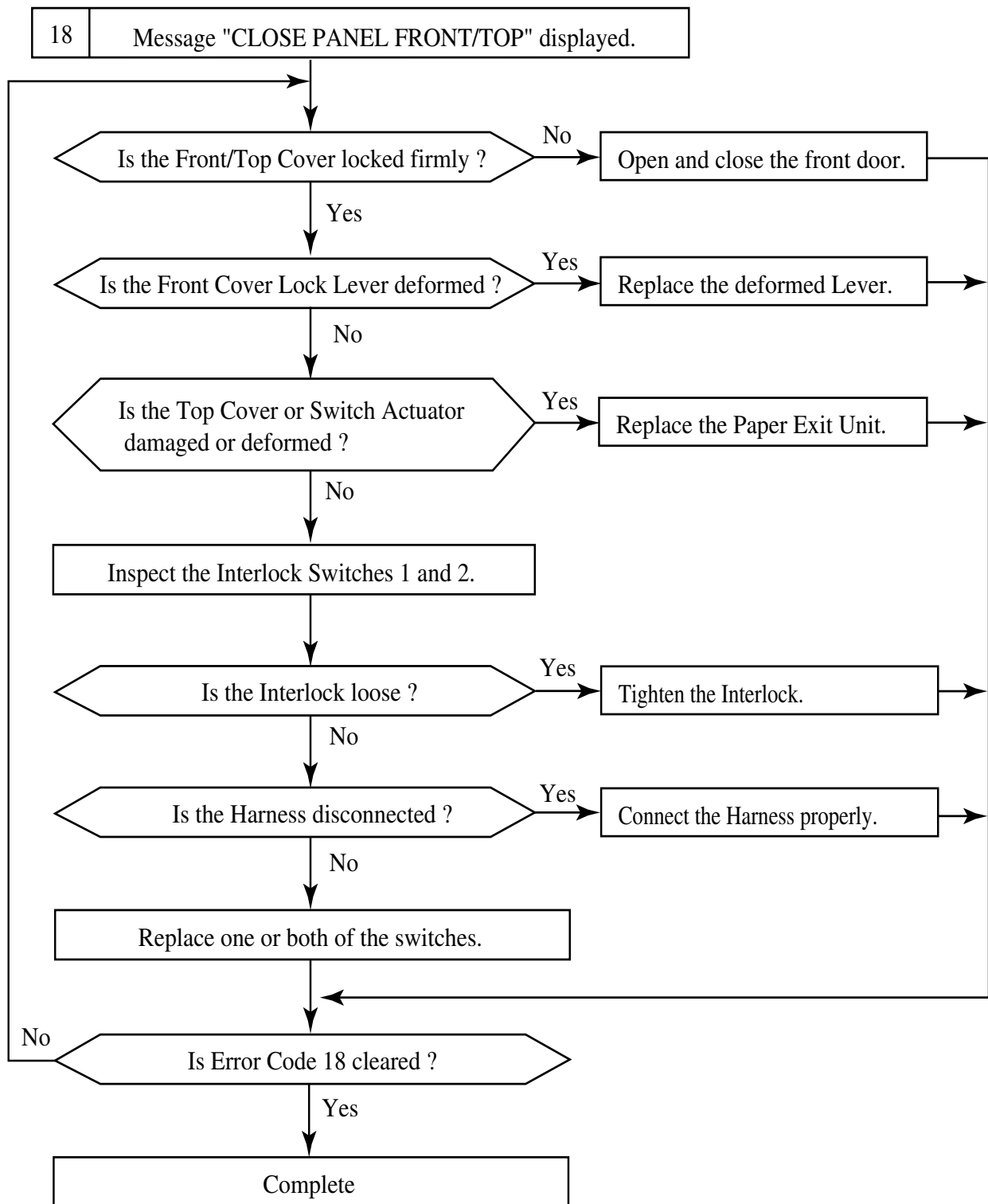

Fig. 8-24

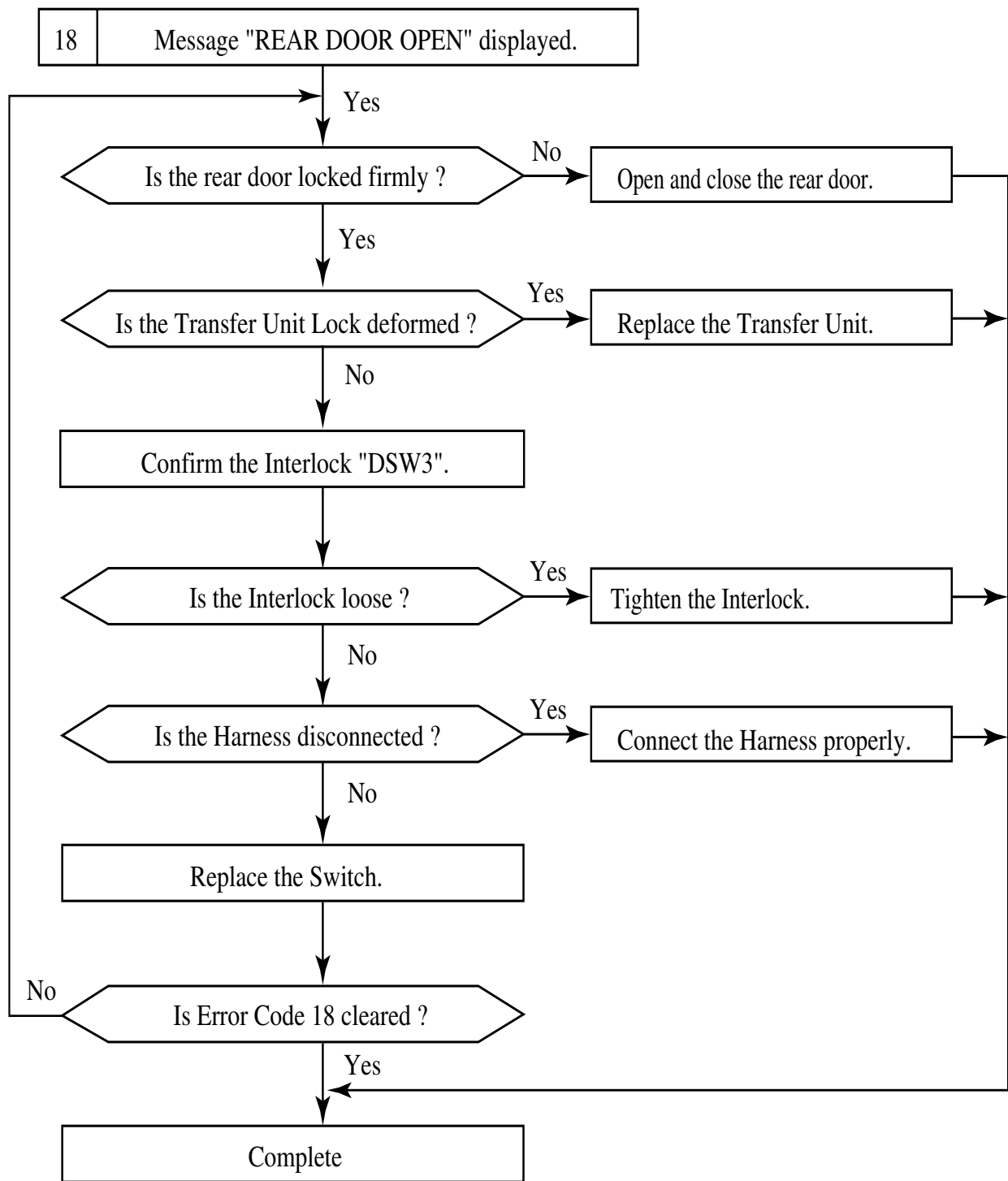

Fig. 8-25

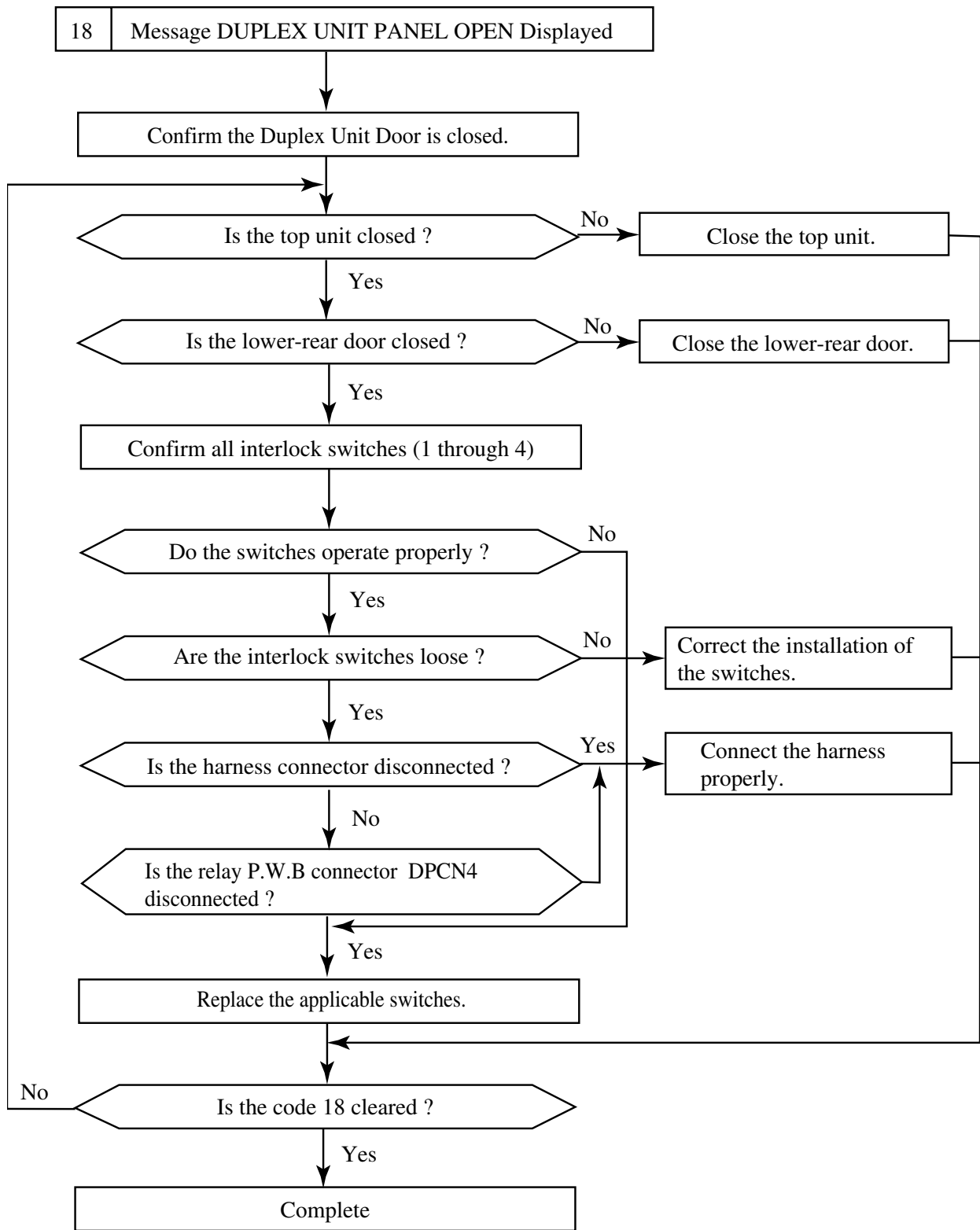

Fig. 8-26

8.3 Paper Transport Errors

8.3.1 Paper Path Overview

Paper is transported through the path shown in Fig. 8-27. Paper jams at the following locations are easily cleared:

- Paper Feeding Part
- Transfer Part
- Fusing Part
- Duplexer Part
- Paper Exiting Part

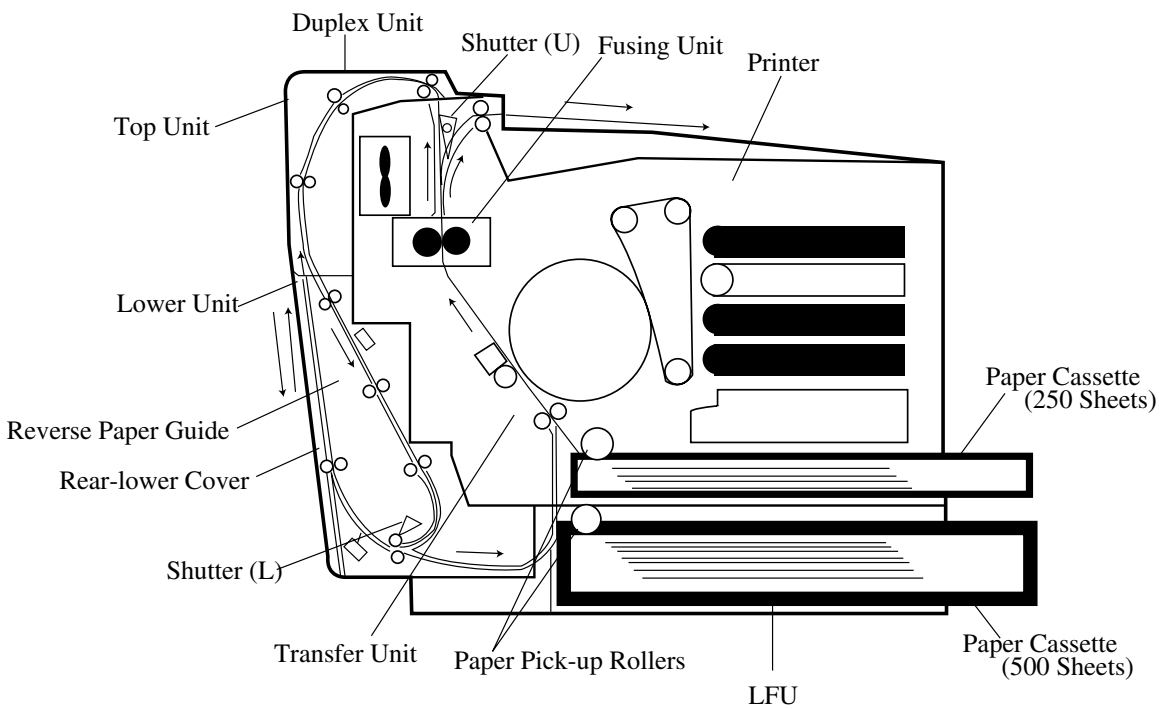

Fig. 8-27

8.3.2 Paper Jam Troubleshooting

8.3.2.1 Misfeed Jams

See Table 8-2 for information on troubleshooting misfeed jams.

Table 8-2: Misfeed Jam Troubleshooting

Problem	Check Item	Result?	Corrective Action
Paper	Is recommended paper being used?	No	Use recommended paper.
	Is the paper damp, or has the paper been opened?	Yes	Replace with new paper.
Paper Cassette	Is the paper loaded correctly?	No	Load the paper correctly.
	Is the end plate properly set?	No	Set the end plate to meet the paper size.
Pick-Up Roller	Is the paper jammed in the paper feed section?	Yes	Remove the jammed paper.
	Is the pick-up roller damaged?	Yes	Replace the damaged pick-up roller.

8.3.2.2 Inner Jams

See Table 8-3 for information on troubleshooting misfeed jams.

Table 8-3: Inner Jam Troubleshooting

Problem	Check Item	Result?	Corrective Action
Transfer Unit	Open the transfer unit and check the following:		
	Is there any paper inside the unit?	Yes	Remove the paper.
	Is the transfer roller firmly locked by the lock lever?	No	Secure the transfer roller with the lock lever.
	Is the paper discharger unit installed in place?	No	Install the paper discharger unit firmly into place.
	Is the corona of the paper discharger unit damaged?	Yes	Replace the existing paper discharger unit with new unit.
Fusing Unit	Is the fusing unit installed in place?	No	Install the fusing unit firmly in place.
	Is there any paper between the rollers?	Yes	Remove the paper.
	Is fusing oil still in the oil bottle?	No	Replace the existing oil bottle with a new bottle.

8.3.2.3 Duplex Jams

See Table 8-4 for information on troubleshooting misfeed jams.

Table 8-4: Duplex/Inner Jam Troubleshooting

Problem	Check Item	Result?	Corrective Action
Duplexer	Open the top cover of the duplexer.		
	Is the top cover closed?	No	Open and close the top cover, and confirm the cover is closed.
	Is there any paper remaining in the top cover?	Yes	Remove the paper.
	Open the lower-rear cover and reverse paper guide unit. Does any paper remaining?	Yes	Remove the paper.
	Is the lower-rear cover securely closed?	No	Open and close the lower-rear cover, and confirm the cover is closed.
	Is there any paper remaining in the center of the lower-rear cover and reverse paper guide unit?	Yes	Remove the remaining paper.

8.3.2.4 Outer Jams

See Table 8-5 for information on troubleshooting misfeed jams.

Table 8-5: Outer Jam Troubleshooting

Problem	Check Item	Result?	Corrective Action
Paper	Is recommended paper being used?	No	Use recommended paper.
Paper Exit Unit	Is the top cover firmly locked by the lock lever?	No	Open and close the top cover again.

8.4 Printer Errors (non-Operator Call Errors)

If errors or failures occur inside the printer, the applicable error message will be displayed on the operator panel, and the printer stops. If errors or failures repeat after pressing the clear switch, confirm the error code, and then resolve through troubleshooting procedures.

Locate the error code in Table 8-6, and then proceed through the troubleshooting flowcharts.

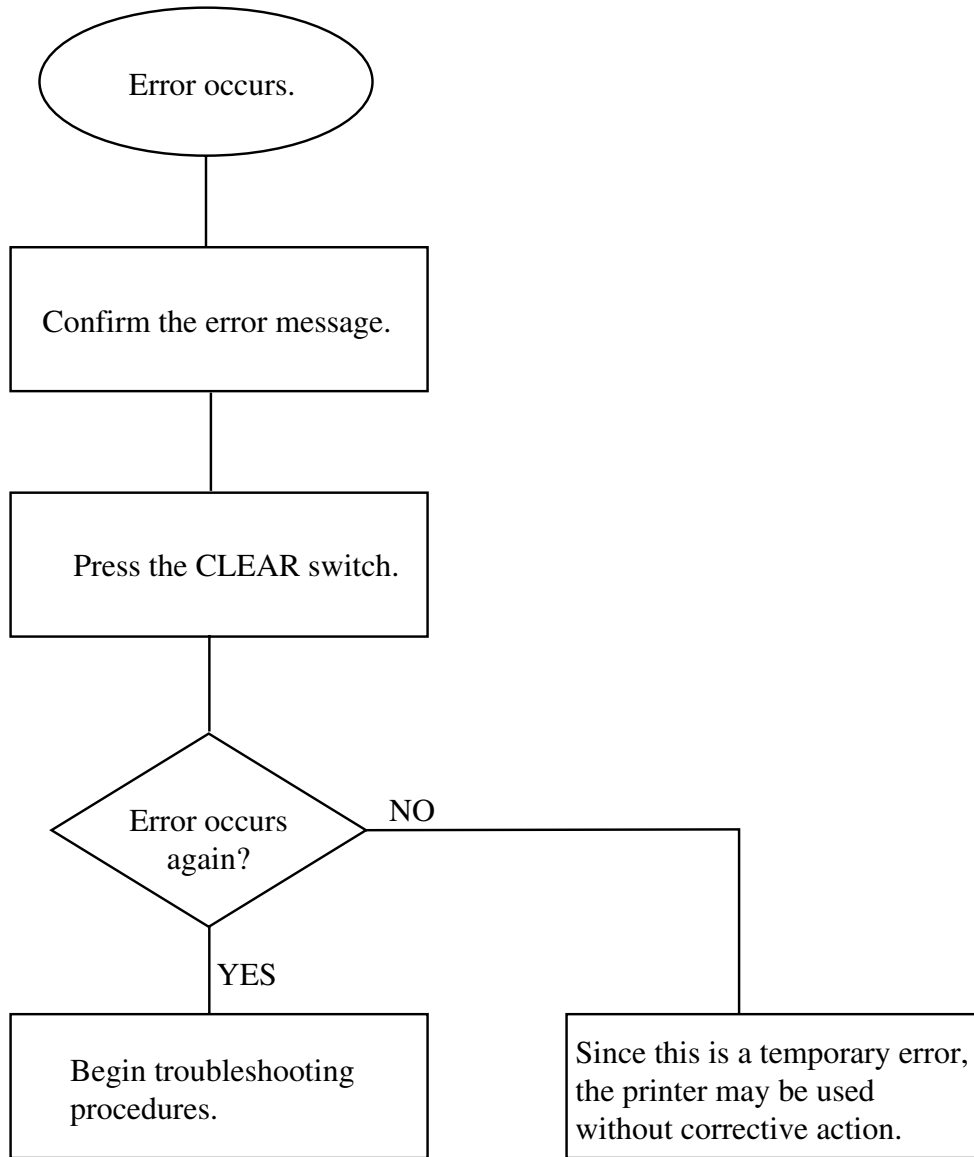

Fig. 8-28

Table 8-6: Printer Error Codes

Figure Number	Code	Description
8-29	C3	NVRAM Error (MCTL P.W.B.)
8-29	C4	Engine Controller MCTL P.W.B. Hardware Error
8-30	C7	Process Timing Clock Error (Main Motor Clock Error)
8-31	D1	Clutch Error of Yellow Developing Unit
8-32	D2	Clutch Error of Magenta Developing Unit
8-33	D3	Clutch Error of Cyan Developing Unit
8-34	D4	Clutch Error of Black Developing Unit
8-35	D5	HPSI Signal Error (Retract Error of Black and Yellow Toner Cartridge)
8-36	D6	HPSI Signal Error (Retract Error of Cyan and Magenta Toner Cartridge)
8-37	E1	Developing Motor Error
8-38	E2	Main Motor Error
8-39	E3	Transfer Drum Rotational Error
8-40	E4	Toner Empty Sensor Error (TPD)
8-41	E5	Transfer Roller Solenoid Error
8-42	E6	Brush Cleaner Solenoid Error
8-43	E7	Brush Cleaner Clutch Error
8-44	E8	Clutch Error of Fusing Unit
8-45	E9	Belt Sensor Error
8-46	EL	Erase Lamp Error
8-47	F0	Control Fan Error
8-48	F2	Ozone Fan (1) Error

Table 8-6: Printer Error Codes

Figure Number	Code	Description
8-49	F4	Fusing Fan Error
8-50	F5	Charging HV (HVPS) Error
8-51	H0	Fusing Thermistor Error
8-52	H2	Fusing Temperature Error (Warming-Up Time Error)
8-52	H3	Fusing Temperature (3) Error (Heater Continuous ON Time Error)
8-52	H4	Fusing Temperature (4) Error (Heater Continuous OFF Time Error)
8-53	L1	Beam Sensor Error
8-54	L2	Scanner Motor Error
8-55	LL	Laser Power Error
8-56	P1	DCTL Error
8-57	P4	Duplexer Motor Error (DPM1, DPM2)
8-58	P3	P3 Duplexer Solenoid Error (L)
8-59	P5	Duplex Solenoid Error
8-60	P6	Duplex Fan Error

Code	Description of Error	Cause of Error	Clearance Method
C3	NVRAM Error	1. Failure of MCTL P.W.B. CPU EEPROM	1. Power cycle the printer. 2. If step 1 does not work, go to "C3 Error Clearance Procedure." 3. Replace the MCTL P.W.B.

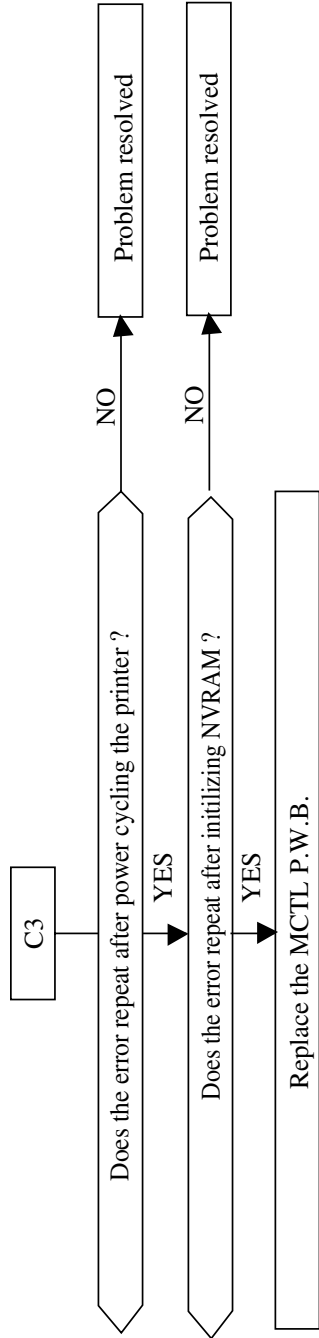

Code	Description of Error	Cause of Error	Clearance Method
C4	Hard Error of MCTL Control Circuitry.	1. Failure of MCTL P.W.B.	1. Power cycle the printer. 2. Replace the MCTL P.W.B.

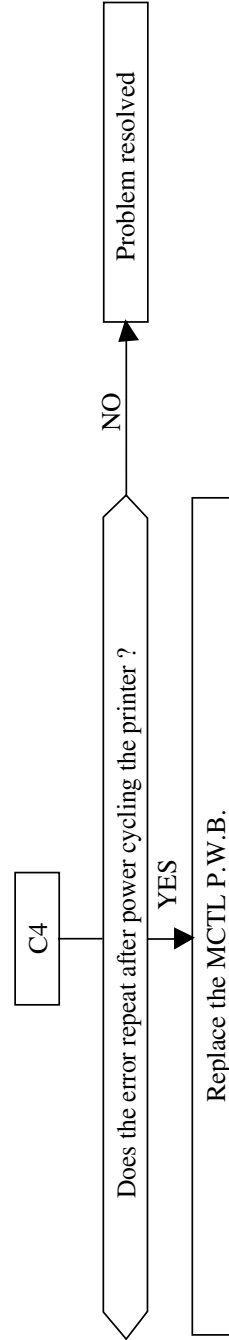

Fig. 8-29

Code	Description of Error	Cause of Error	Clearance Method
C7	Process Timing Error.	<ol style="list-style-type: none"> 1. LVPS Failure 2. MM Failure 3. MM Input Circuit Failure 	<ol style="list-style-type: none"> 1. Implement the same clearance procedures employed for E2 error. [Note]: MM stands for OPC Belt Drive Main Motor.

C7

Implement the clearance procedures employed for E2 error.

Fig. 8-30

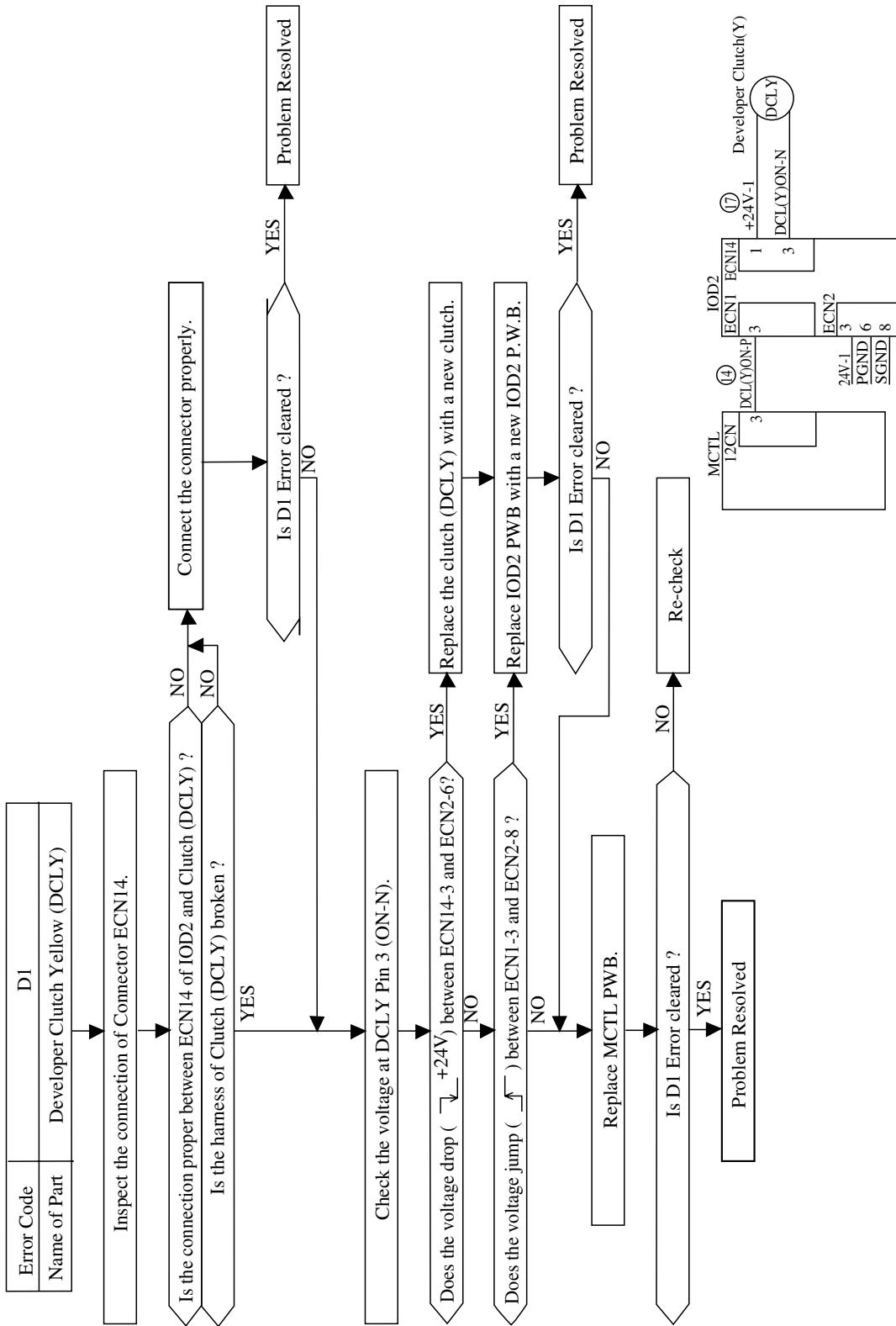

Fig. 8-31

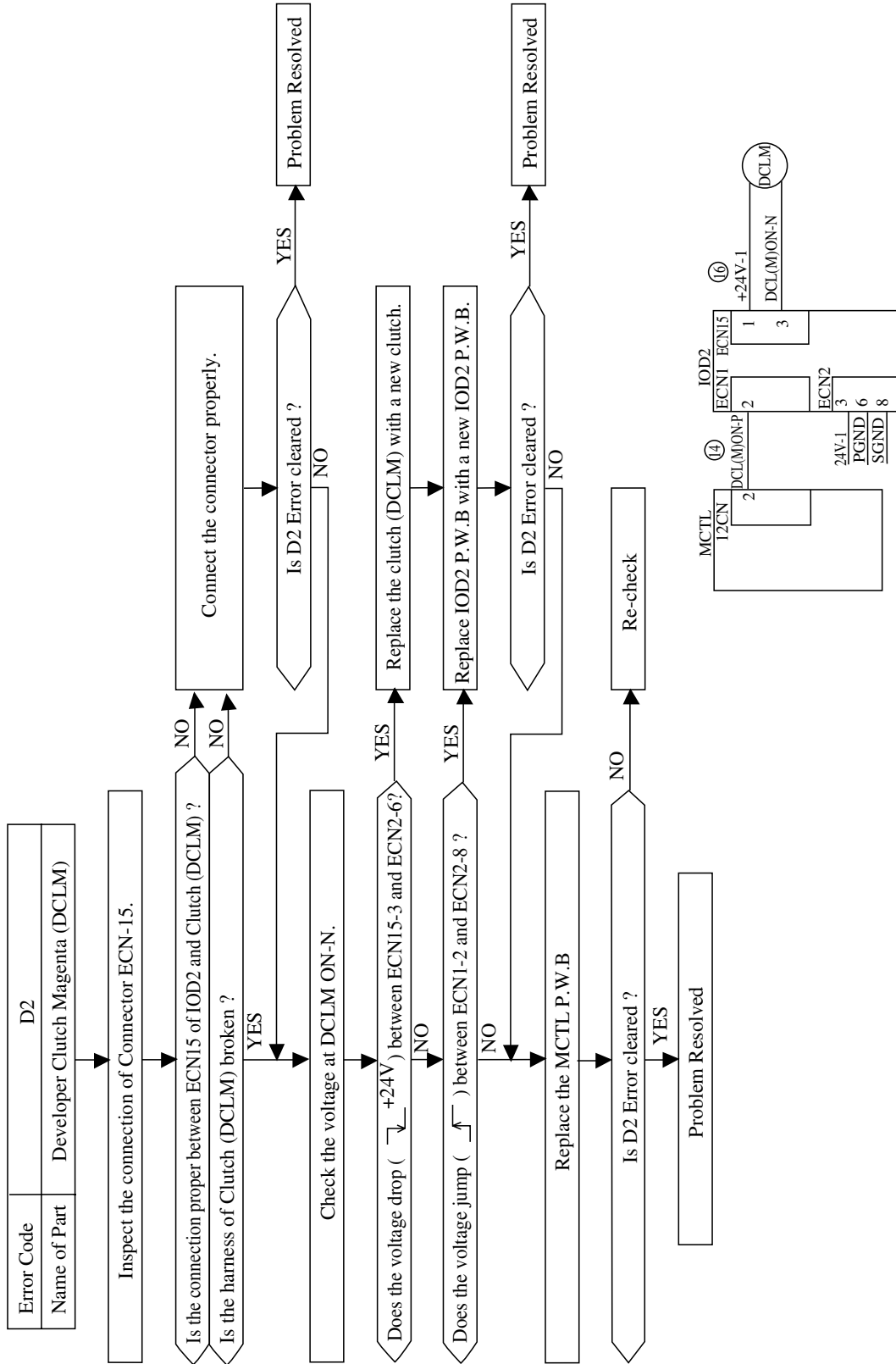

Fig. 8-32

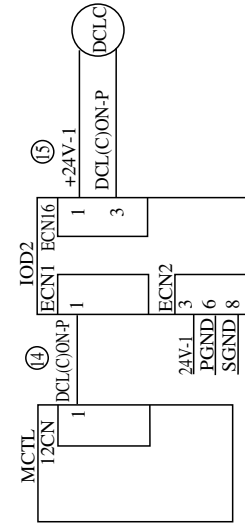
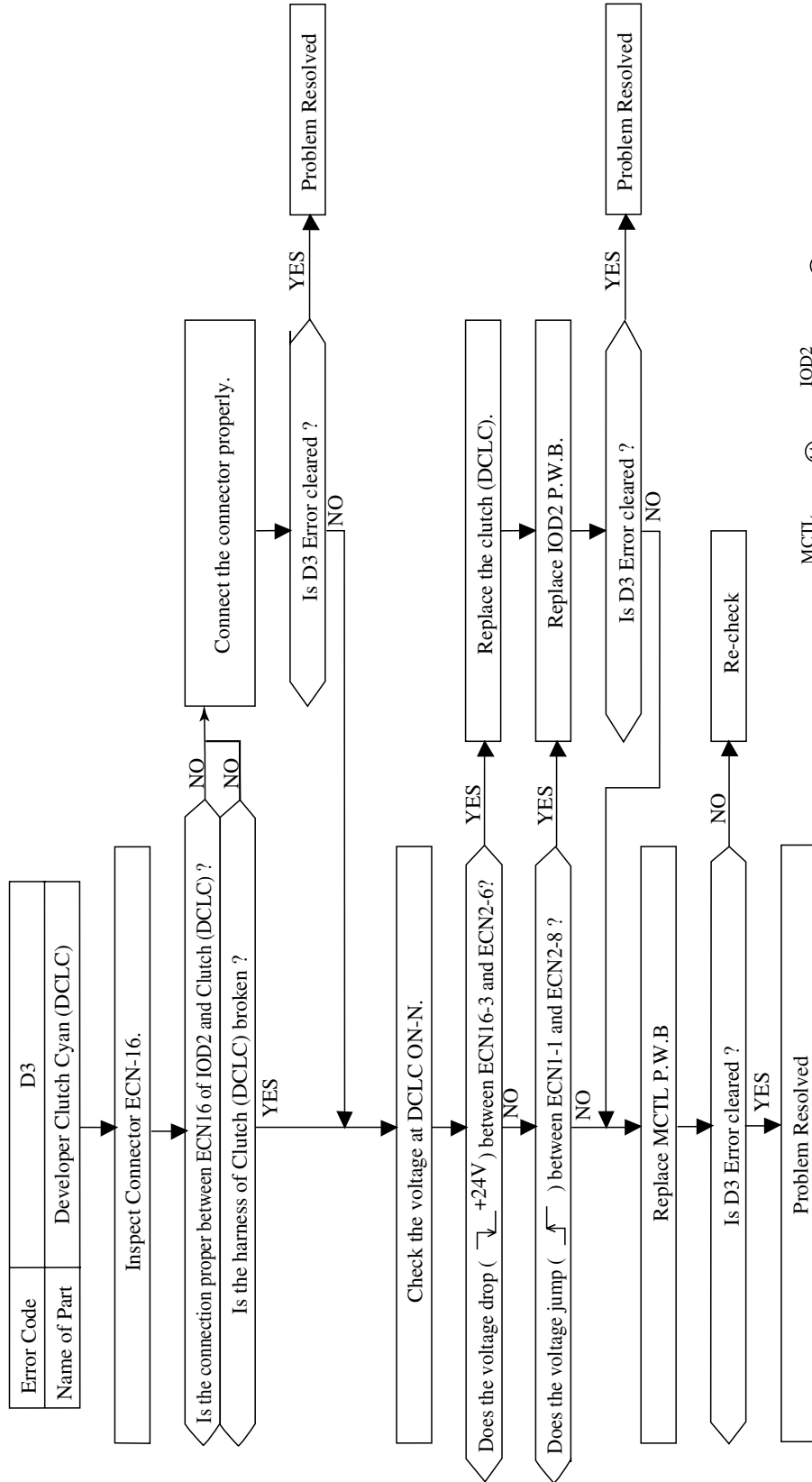

Fig. 8-33

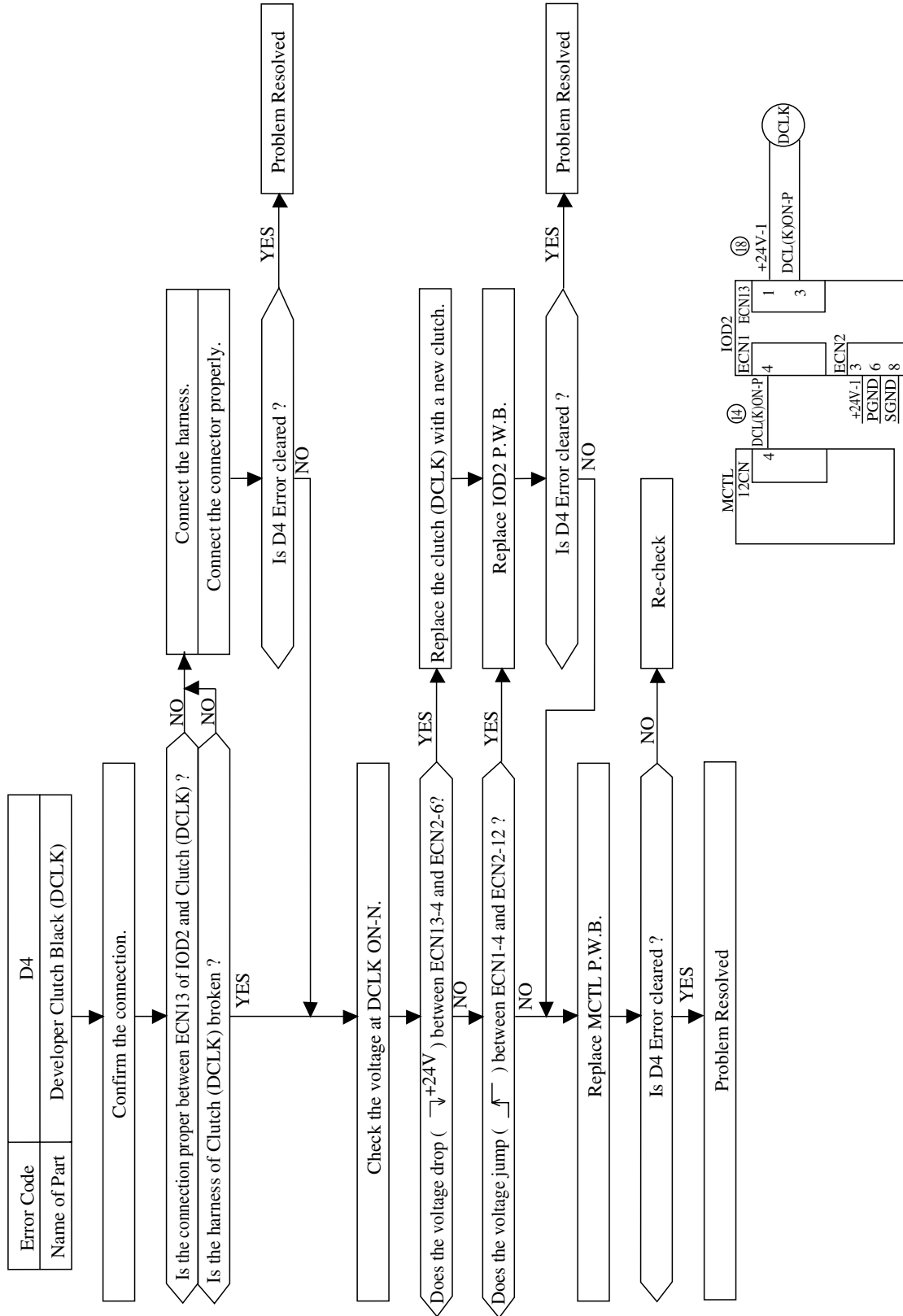

Fig 8-34

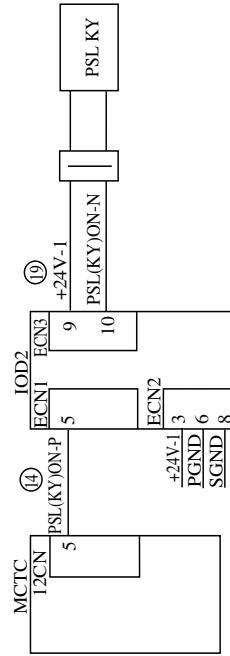
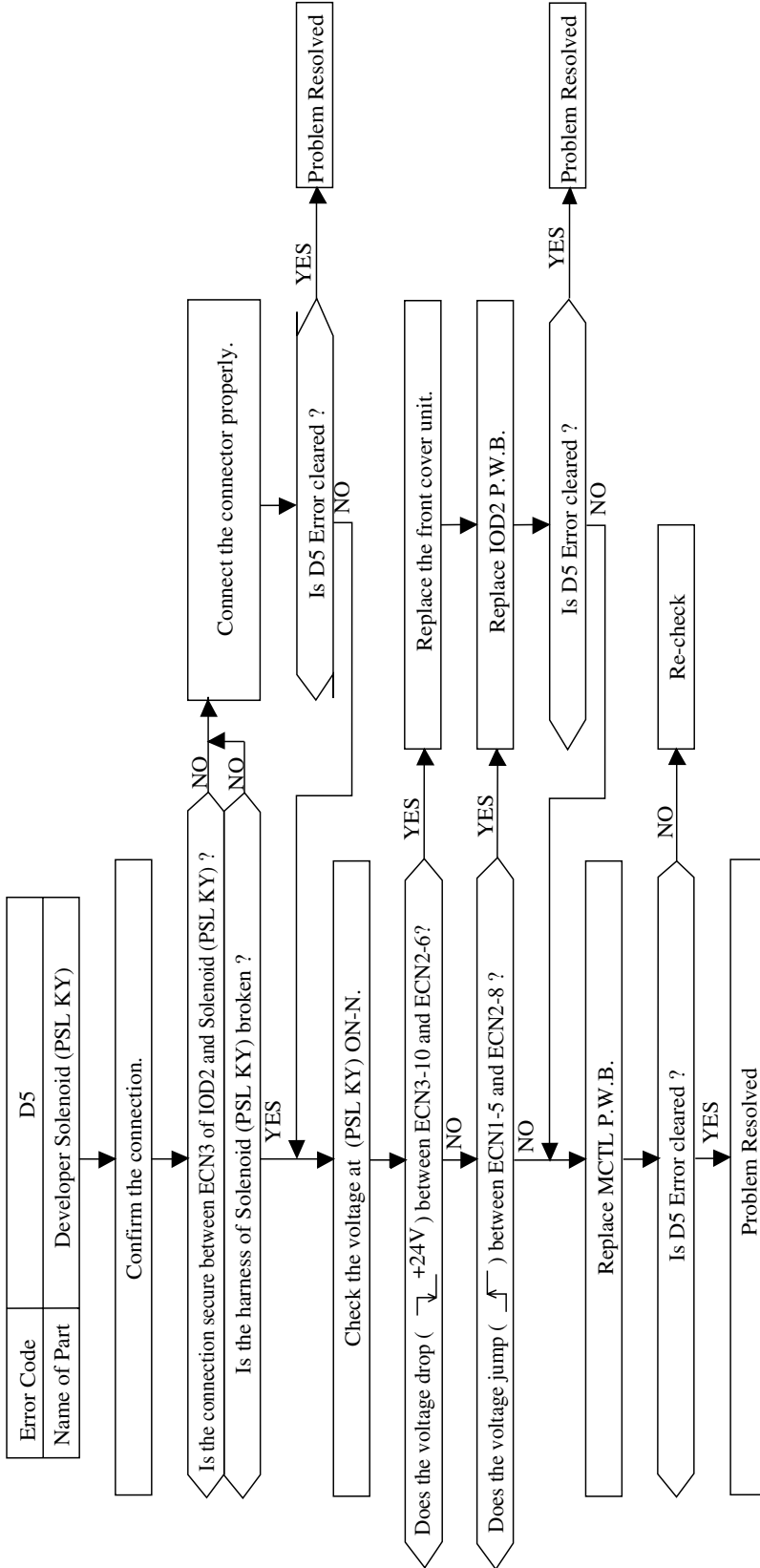

Fig. 8-35

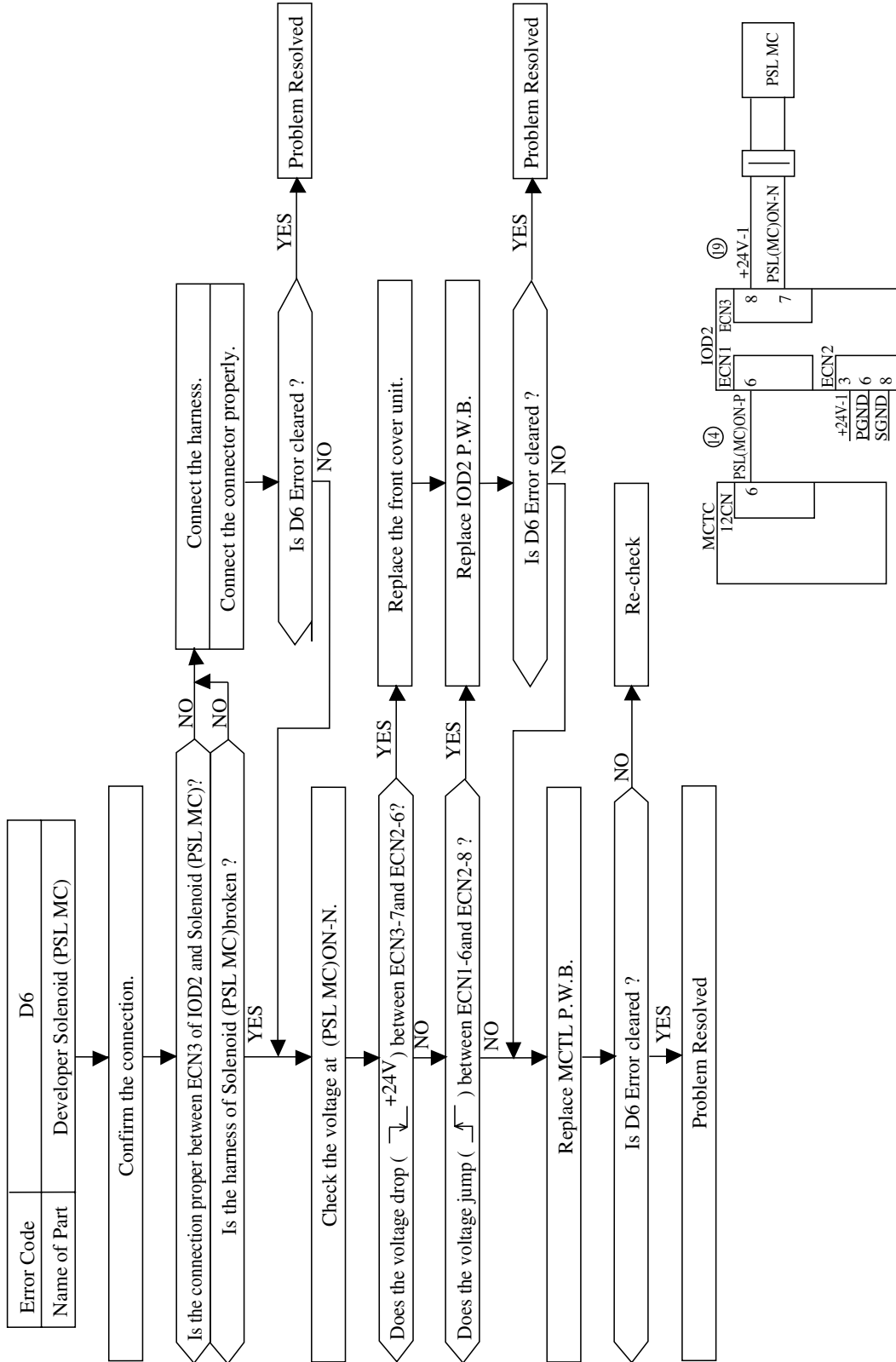

Fig. 8-36

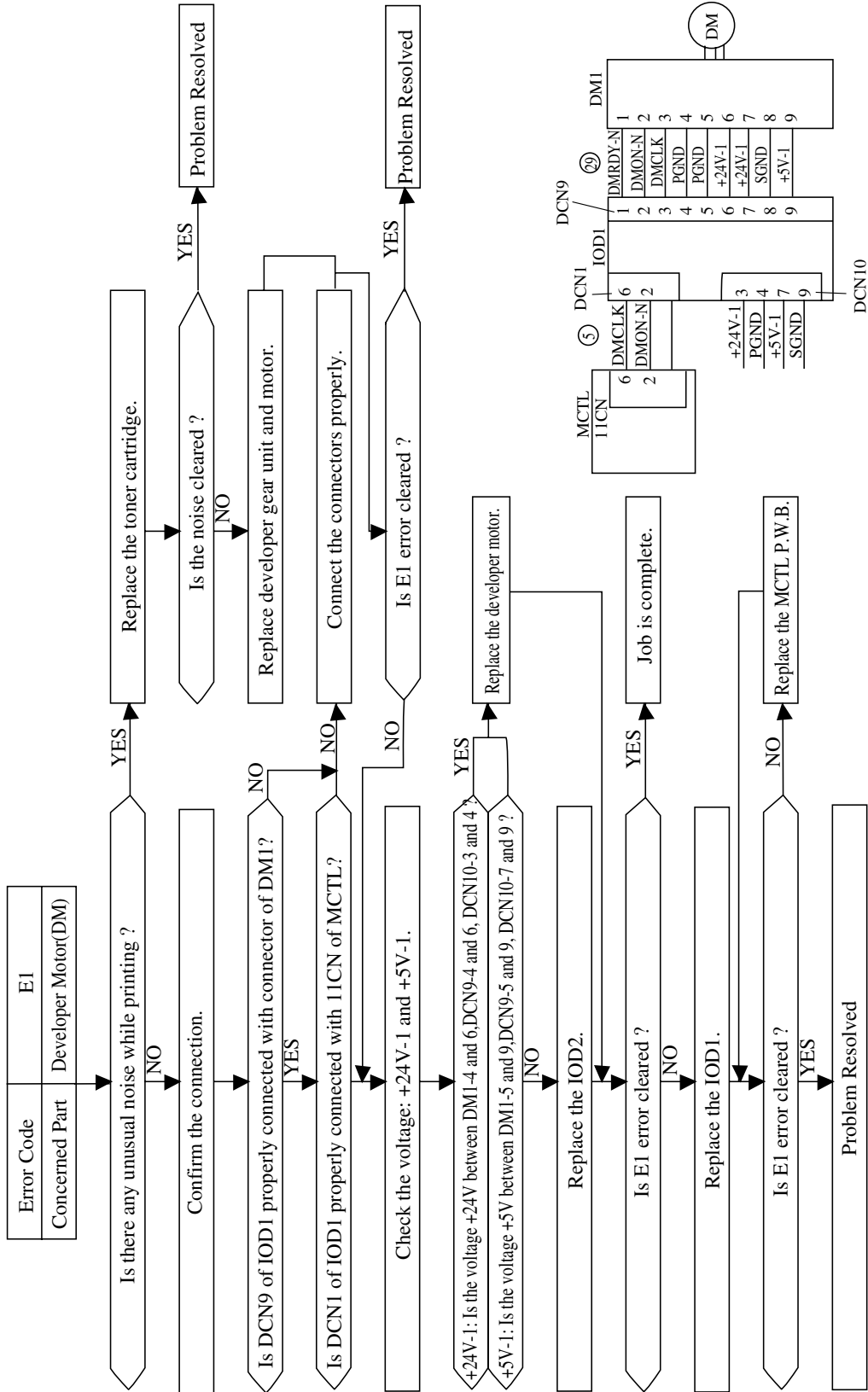

Fig. 8-37

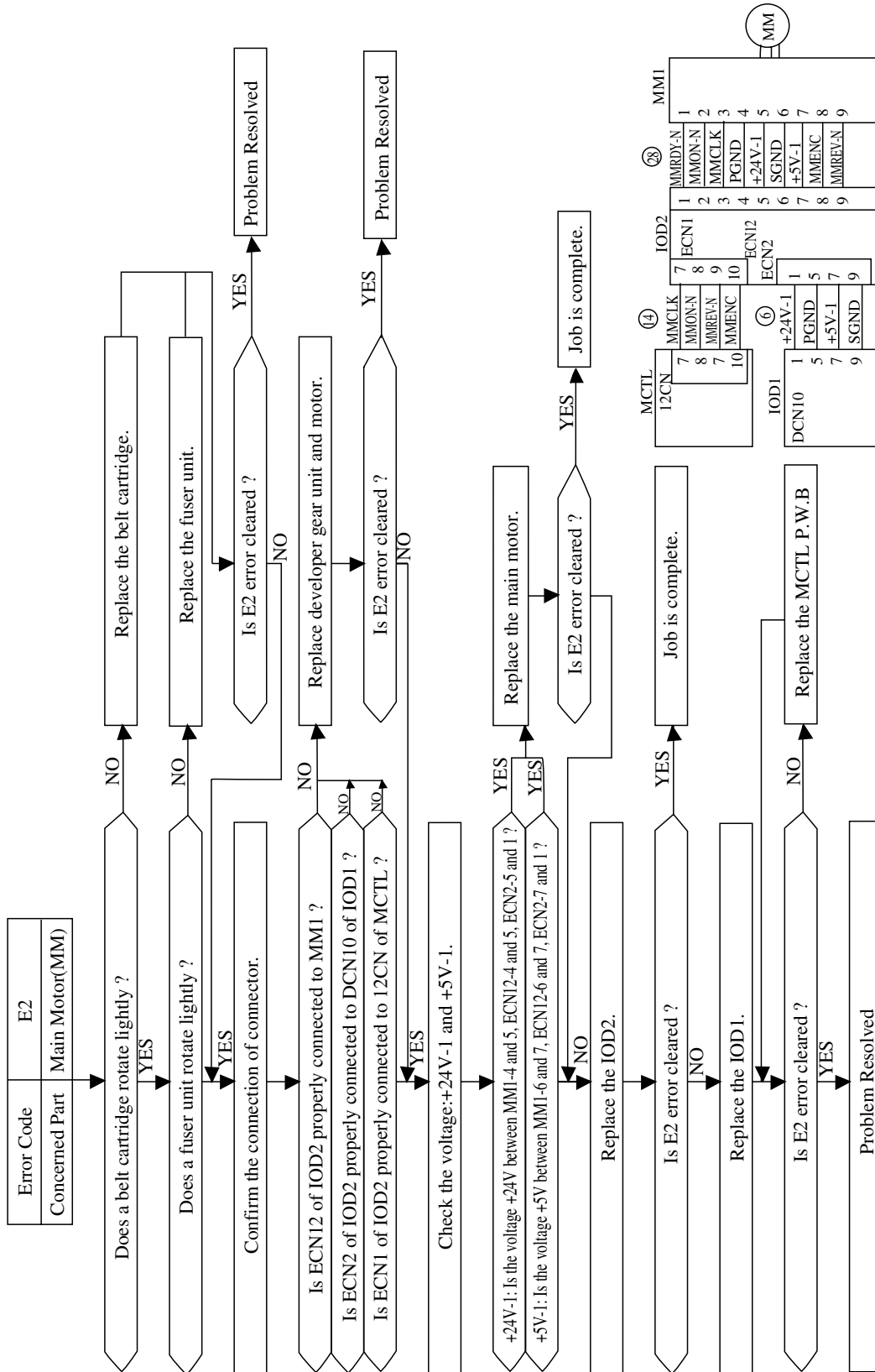

Fig.8-38

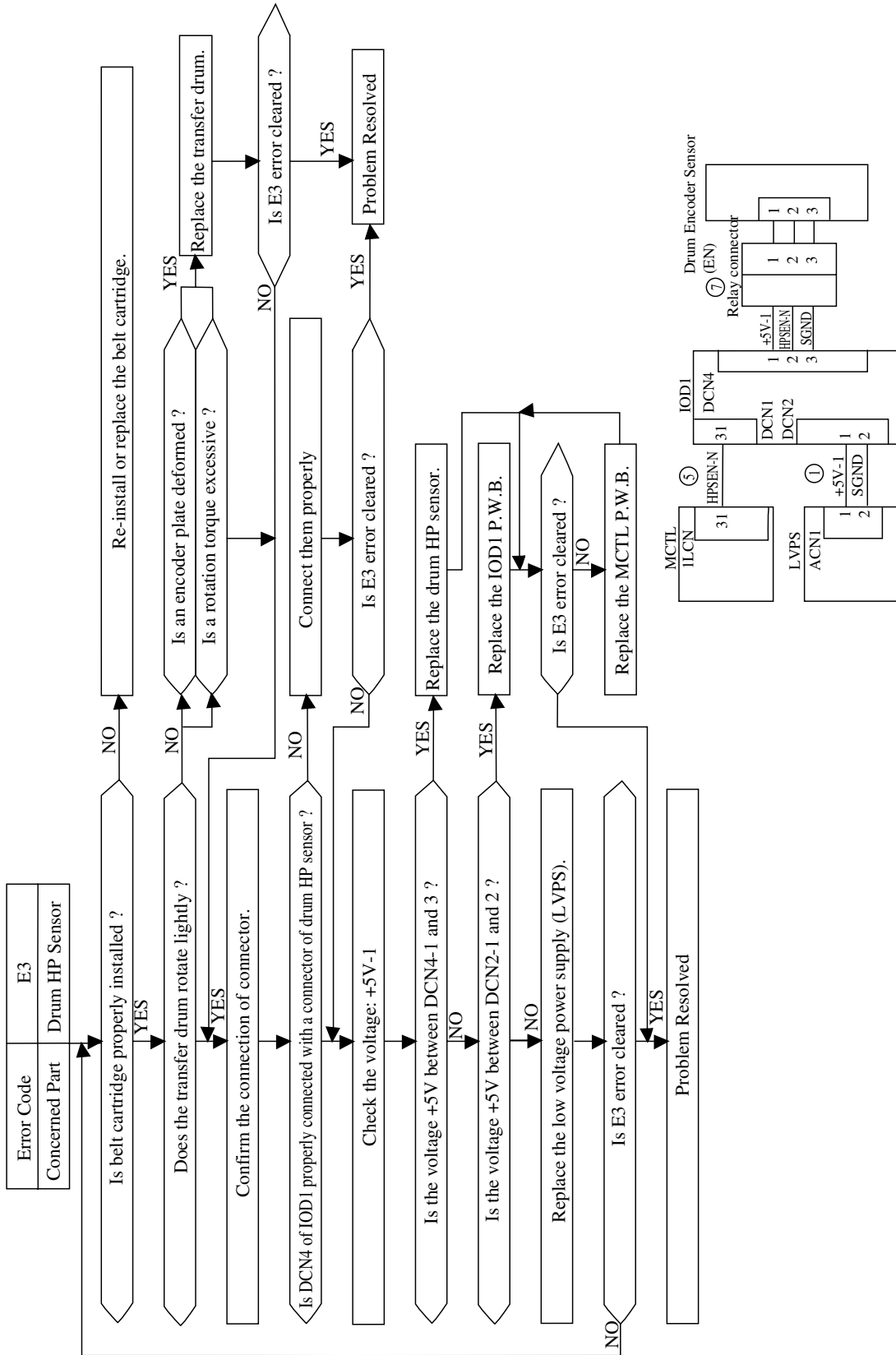

Fig. 8-39

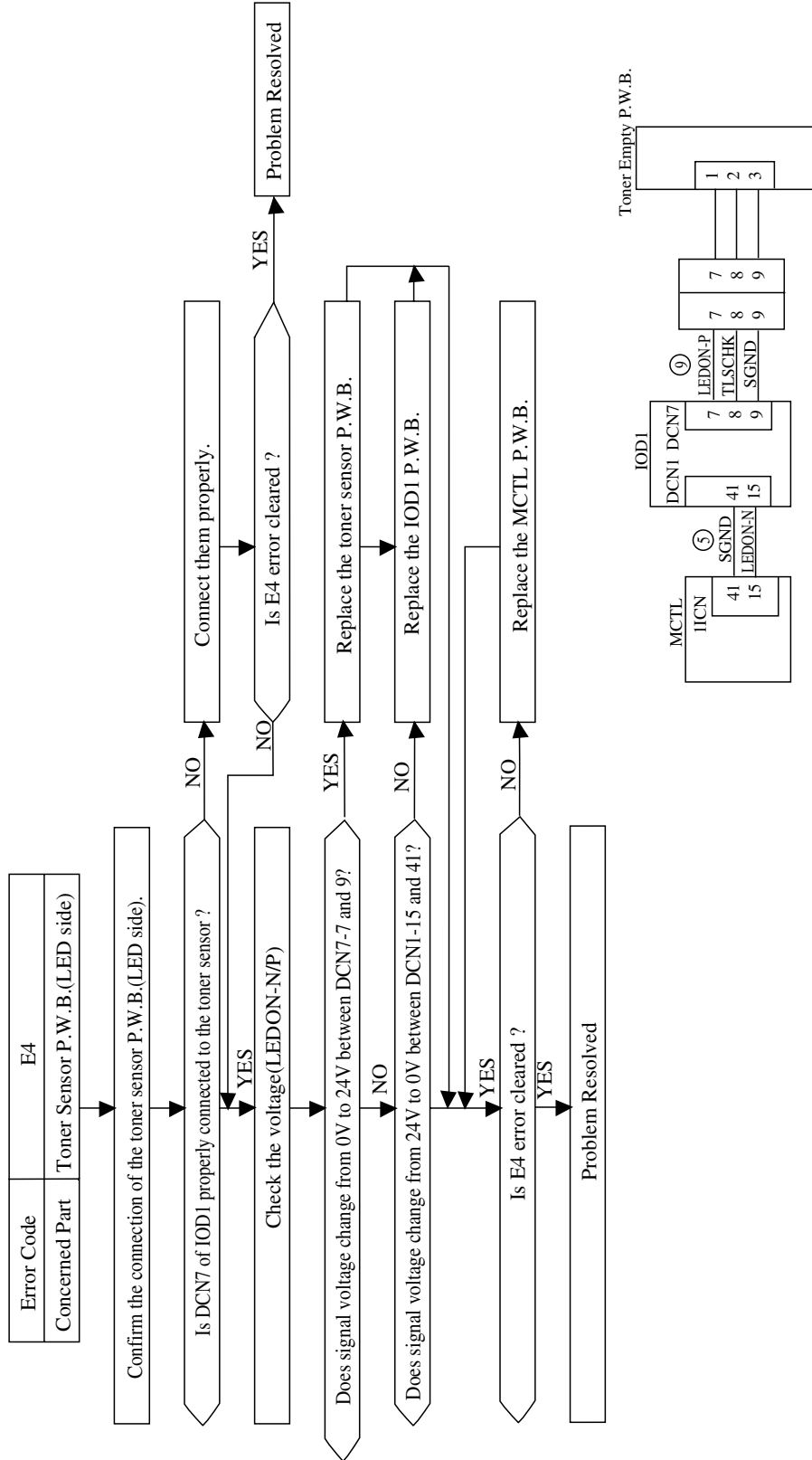

Fig. 8-40

Error Code	E5
Concerned Part	Transfer Cam Clutch (TRCM)

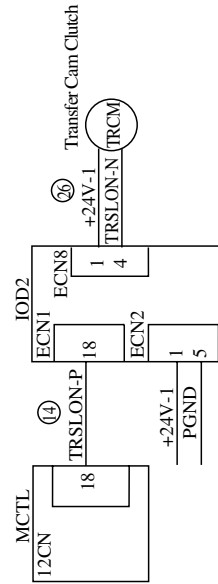
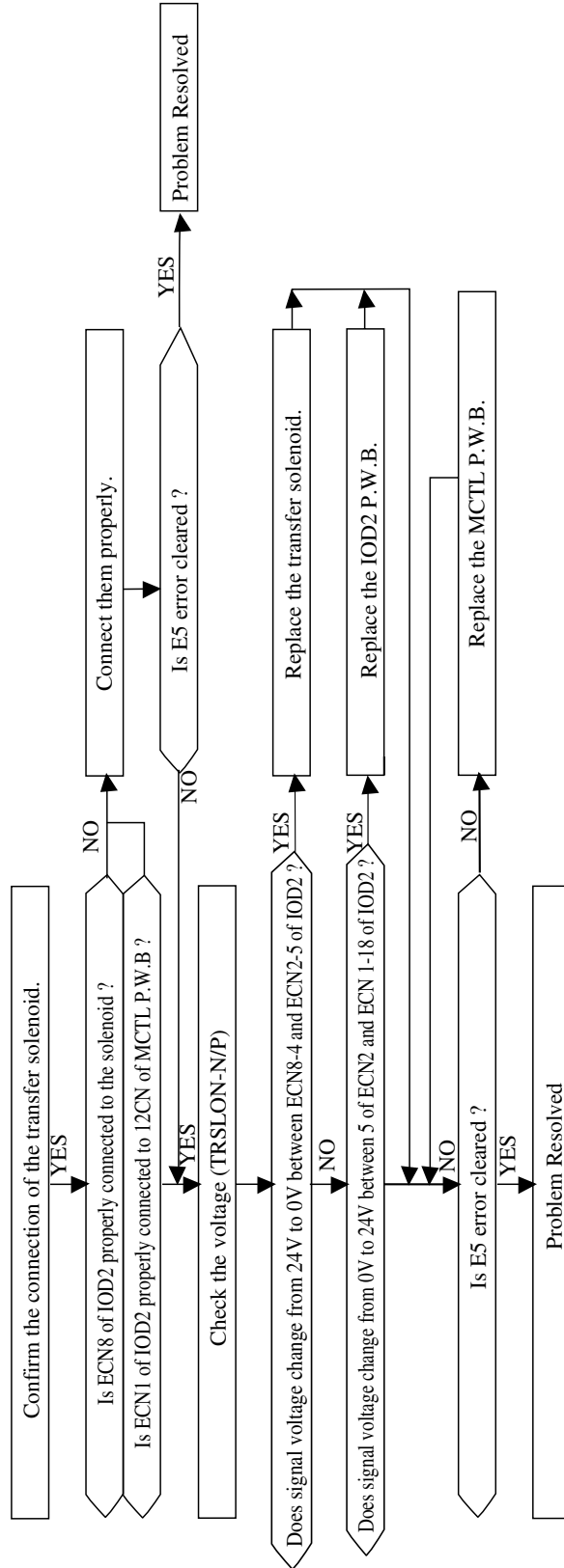

Fig. 8-41

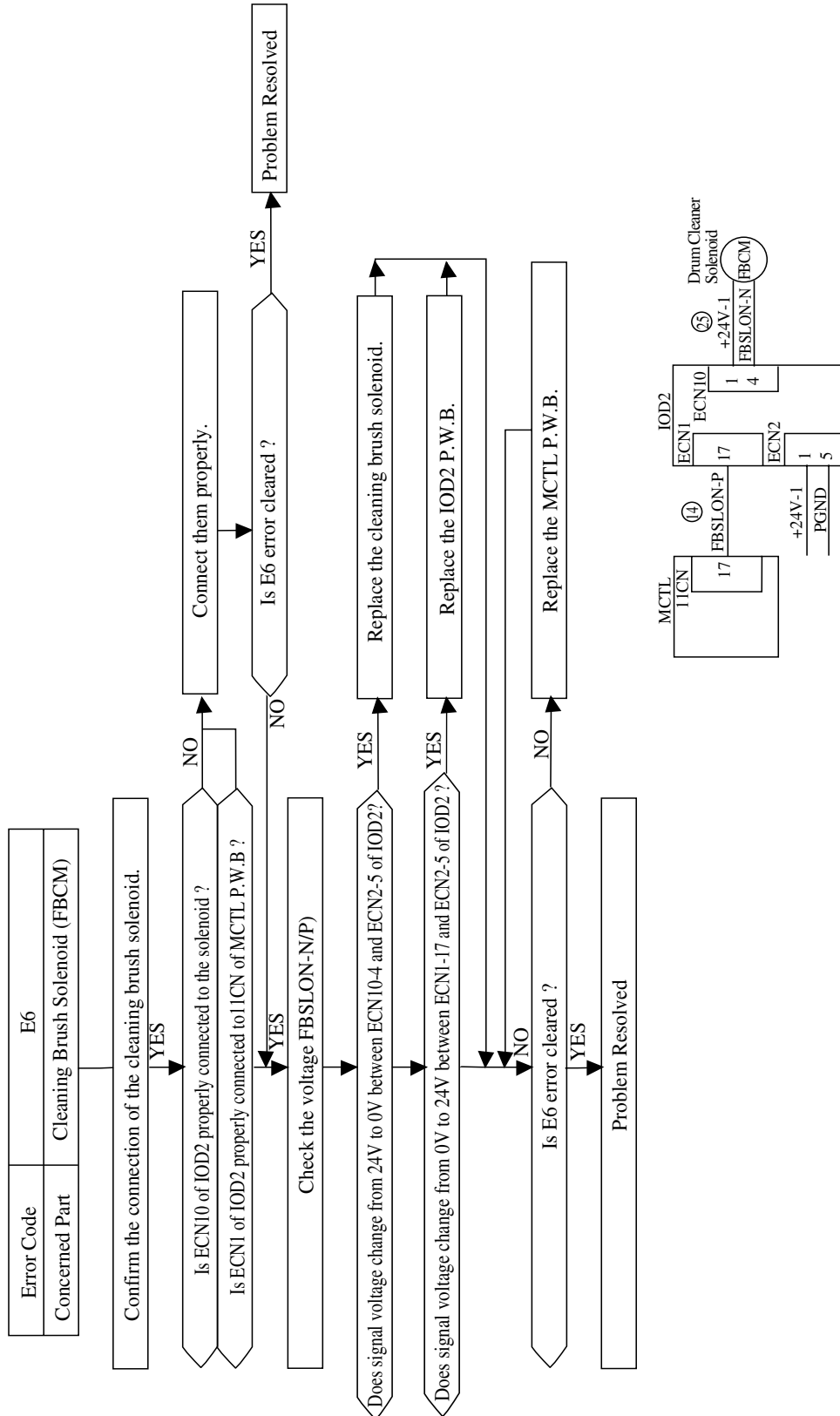

Fig. 8-42

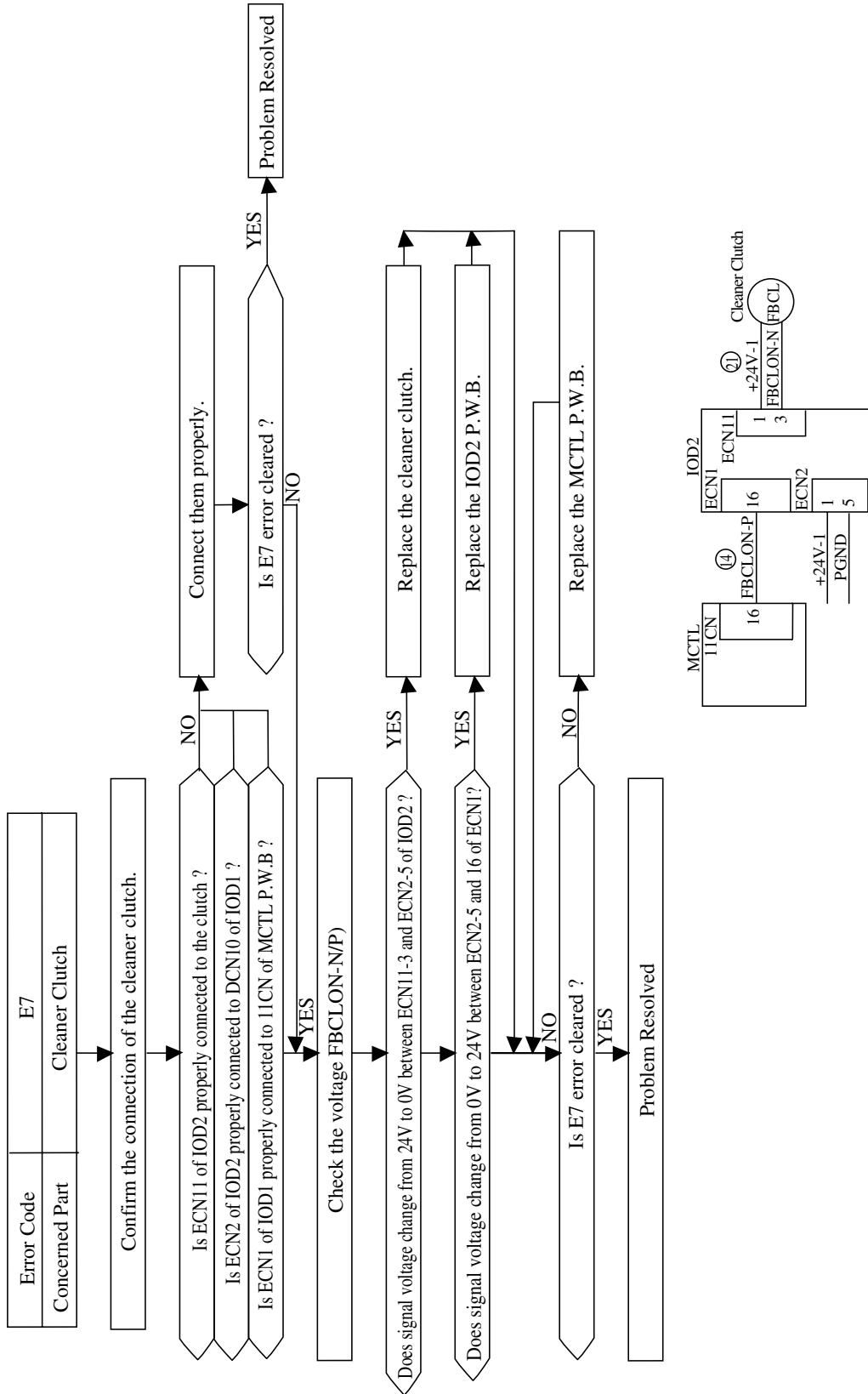

Fig. 8-43

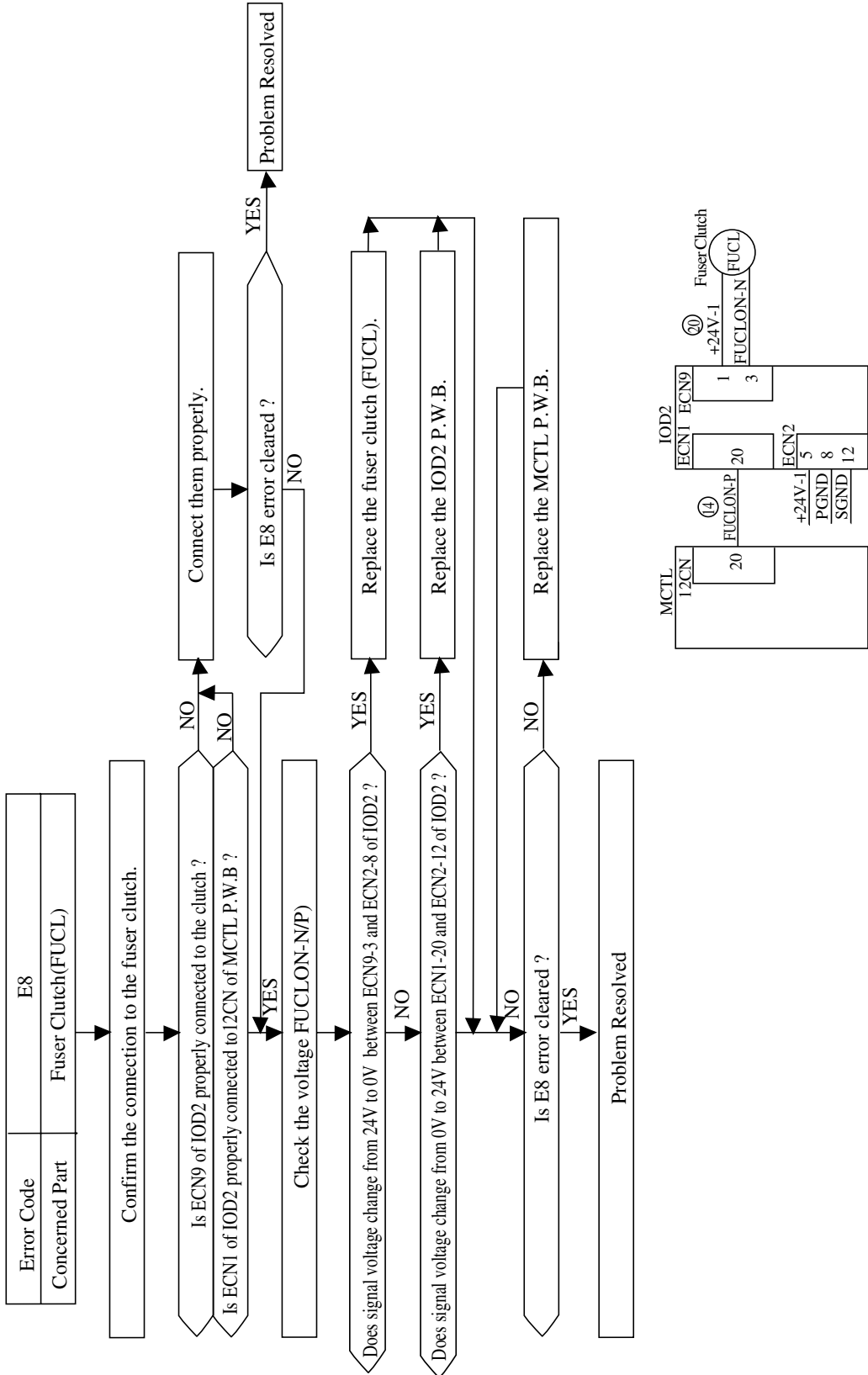

Fig. 8-44

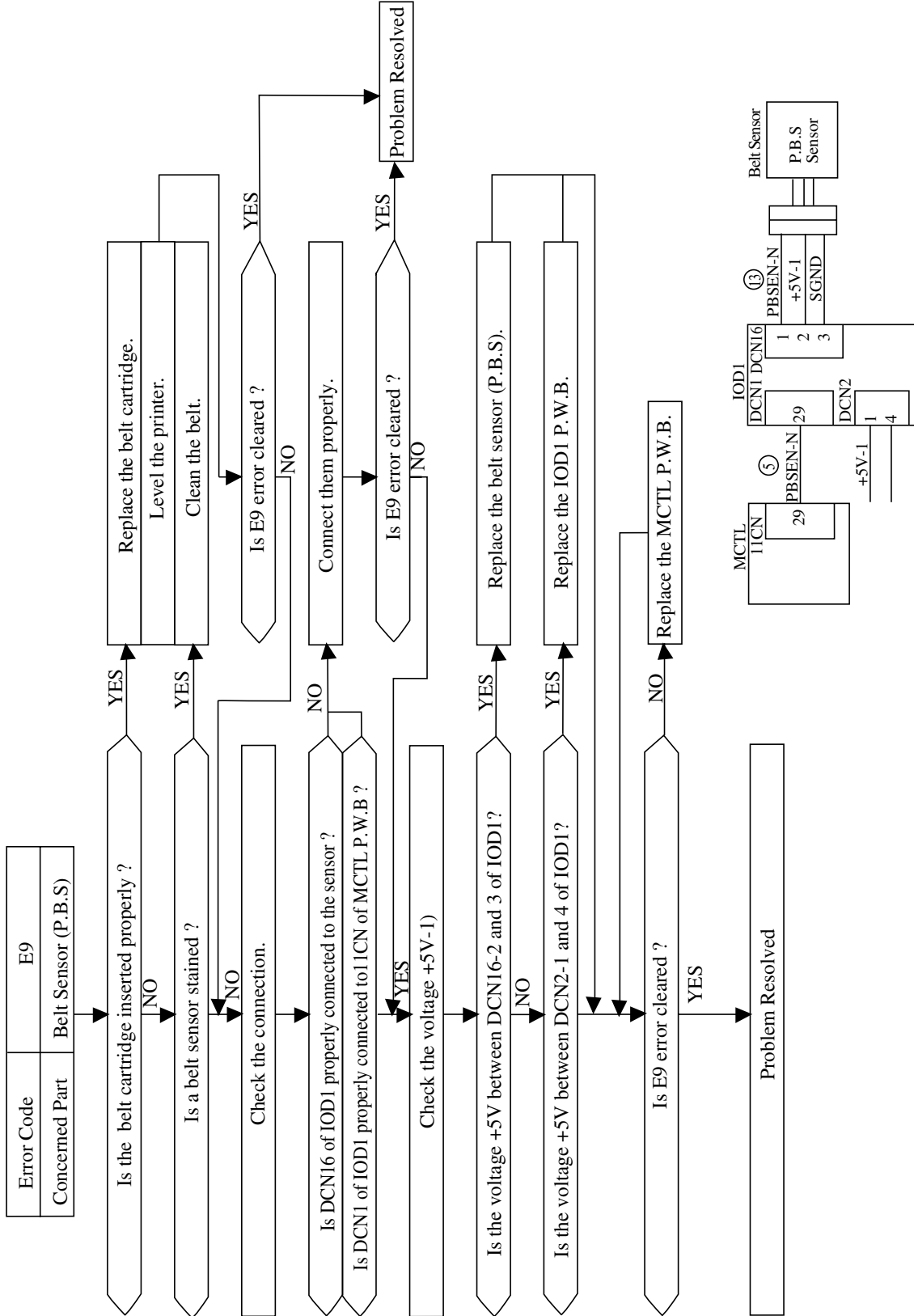

Fig. 8-45

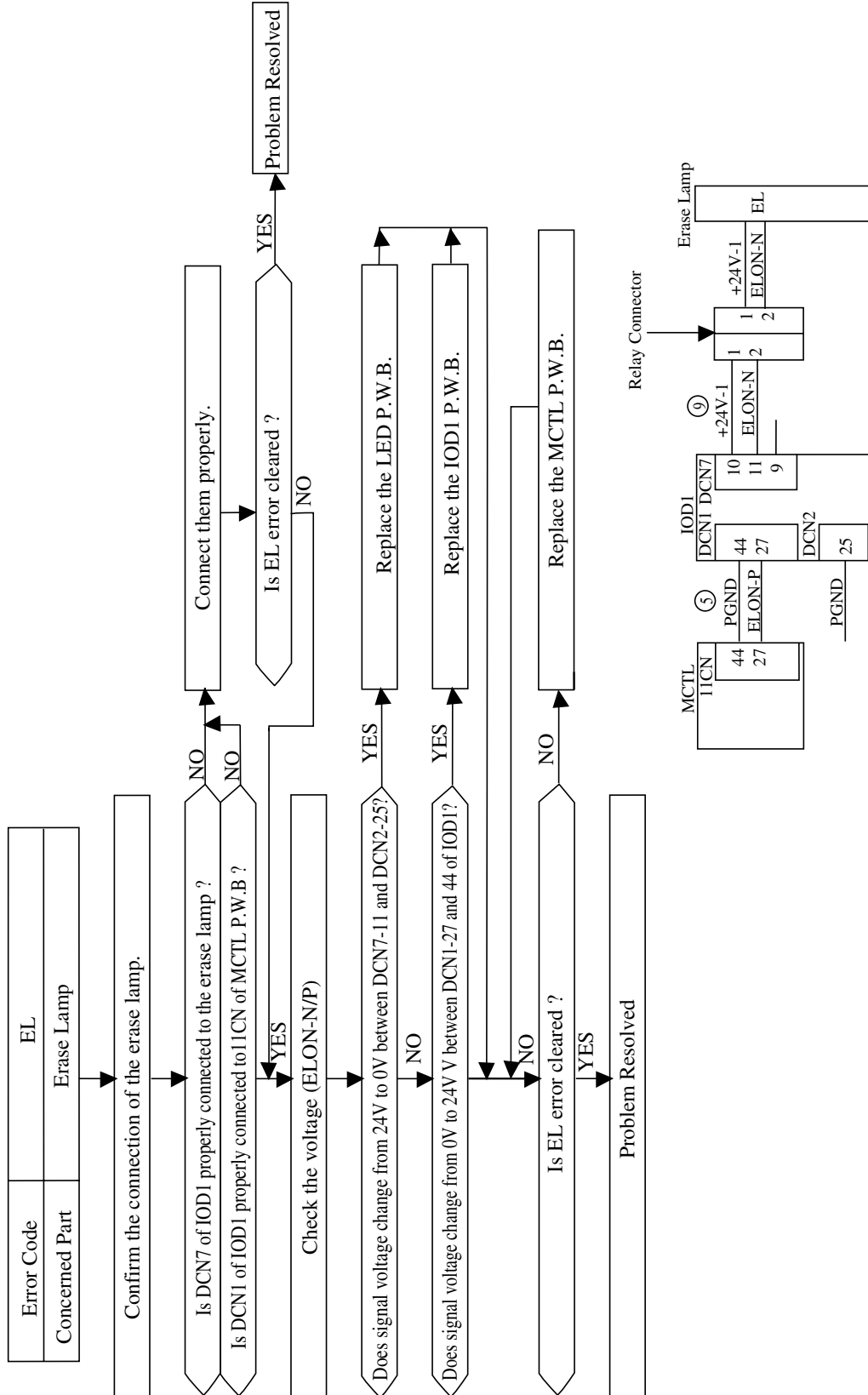

Fig. 8-46

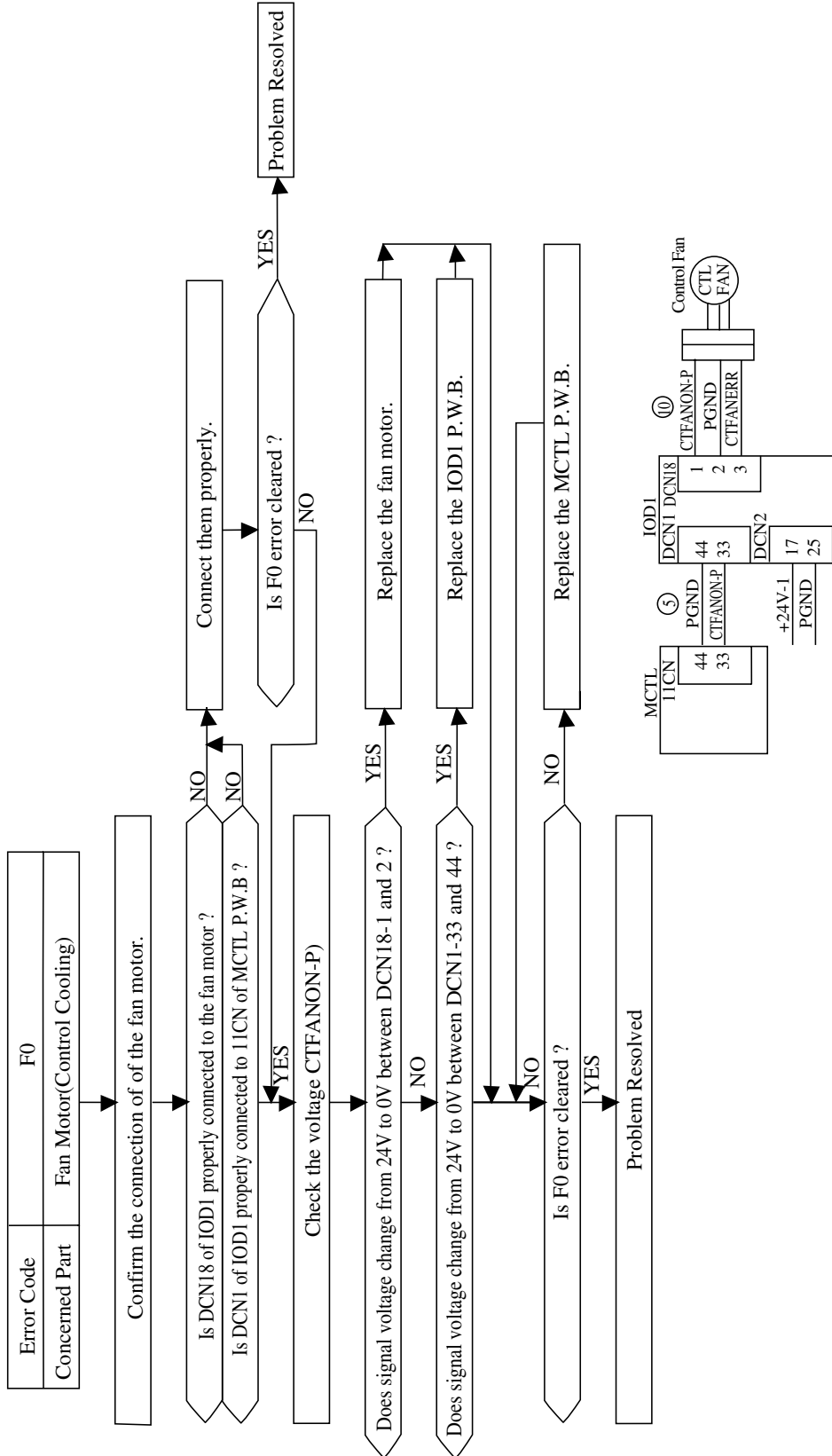

Fig. 8-47

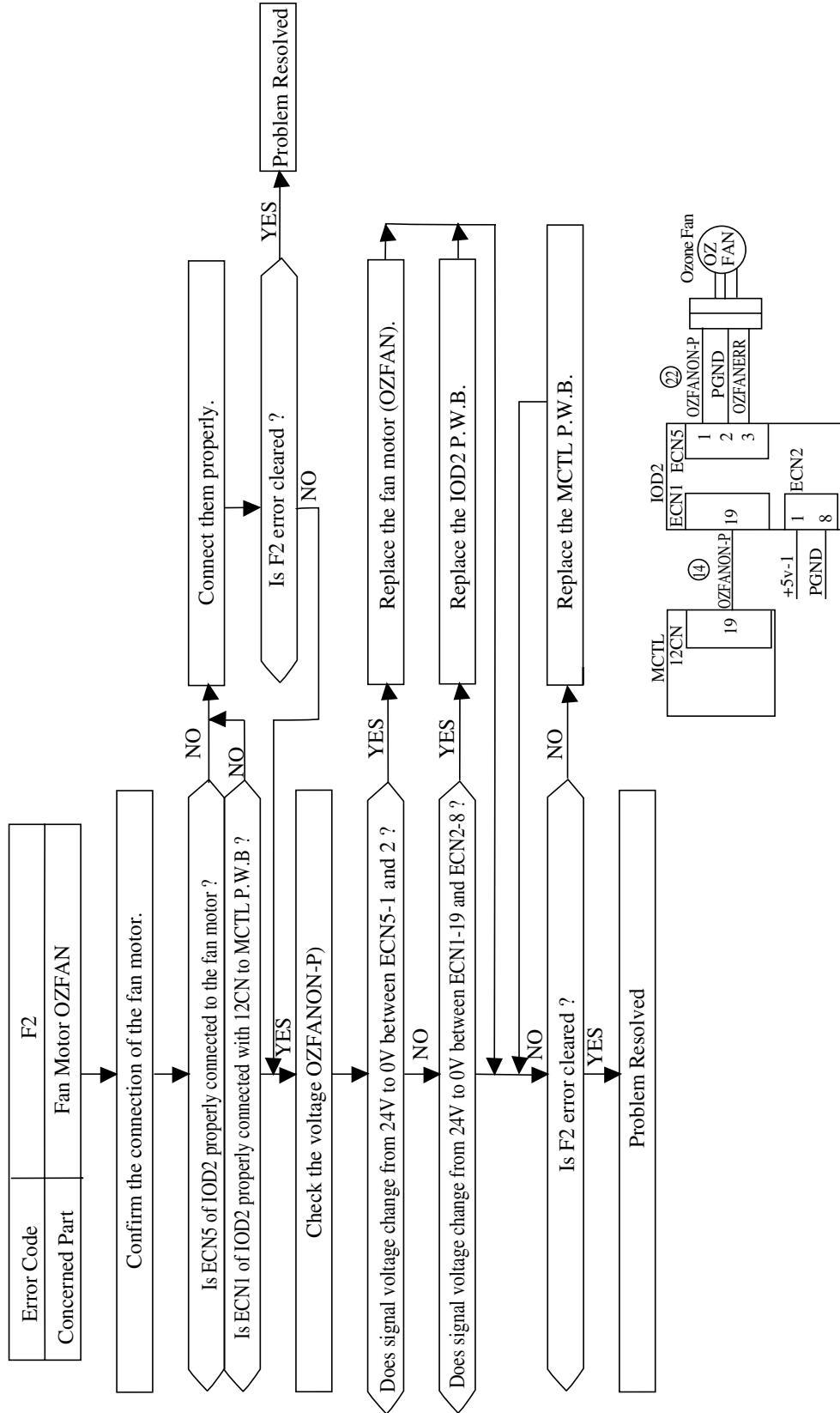

Fig. 8-48

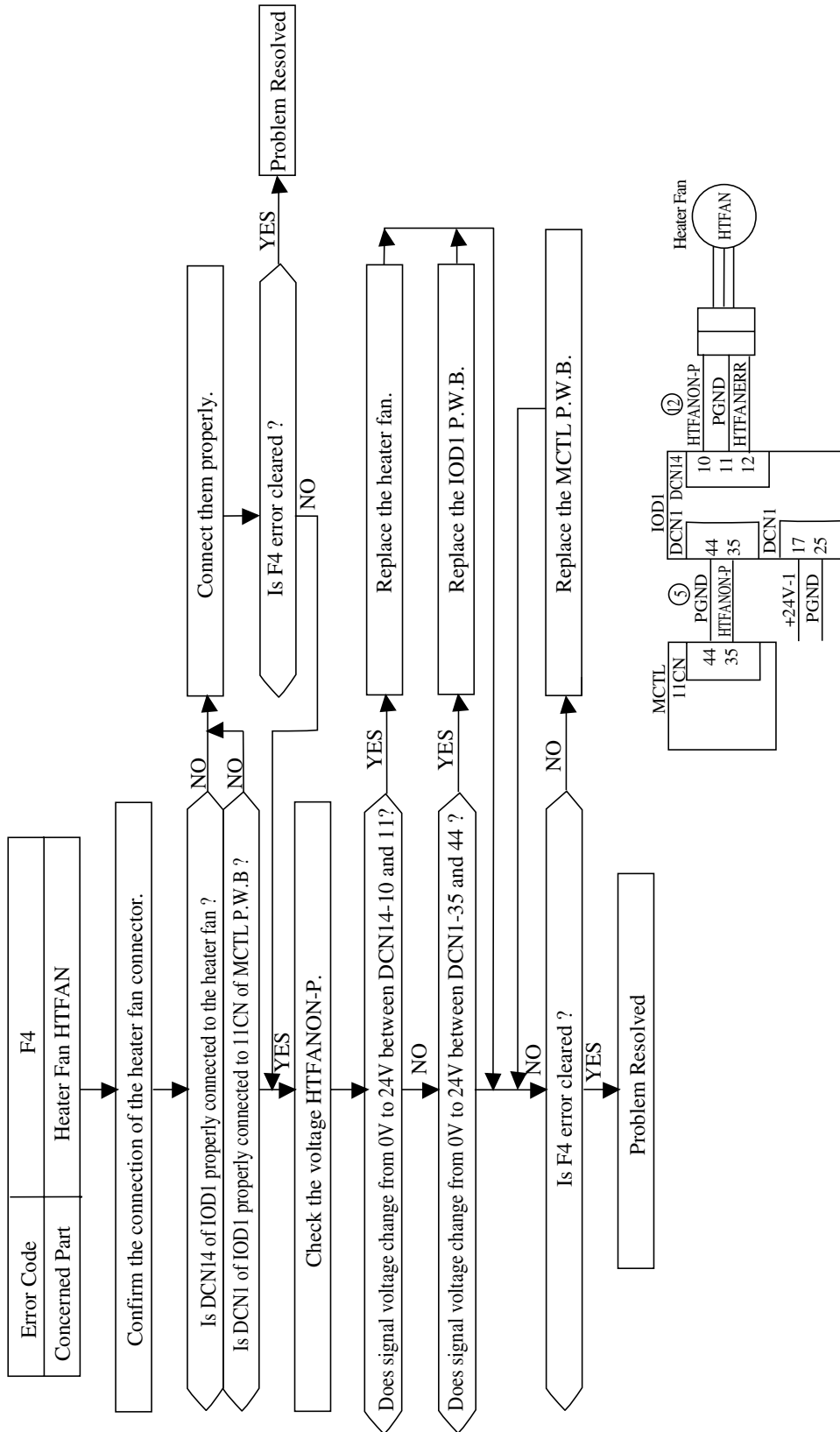

Fig. 8-49

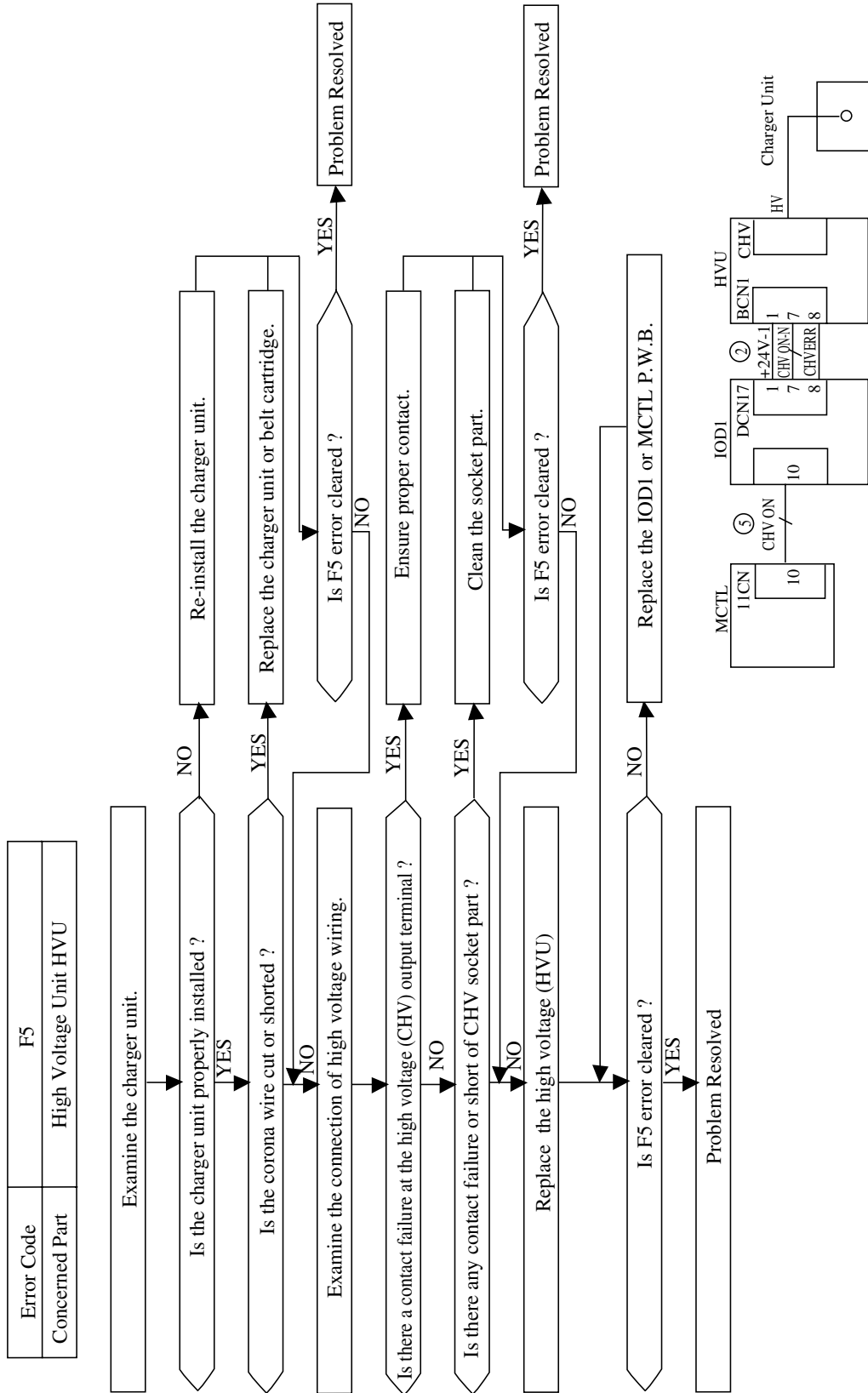

Fig. 8-50

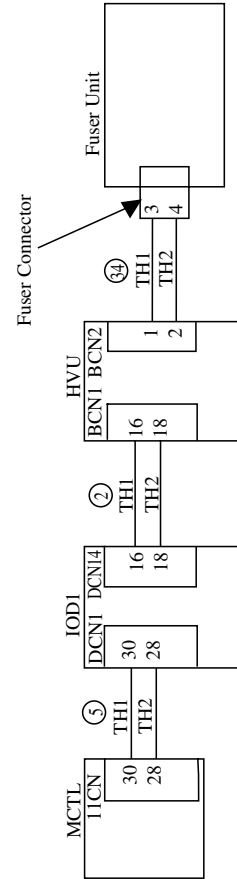
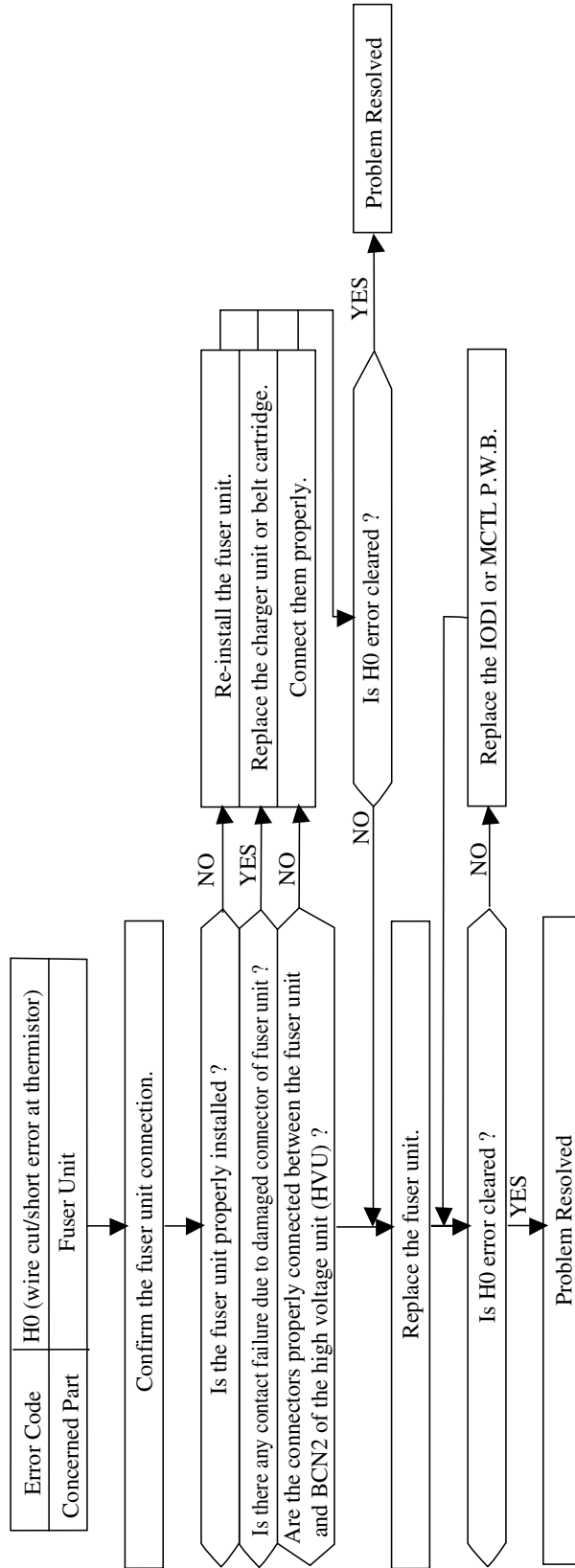

Fig. 8-51

Error Code	H2,H3,H4
Concerned Part	Fuser Unit and Others

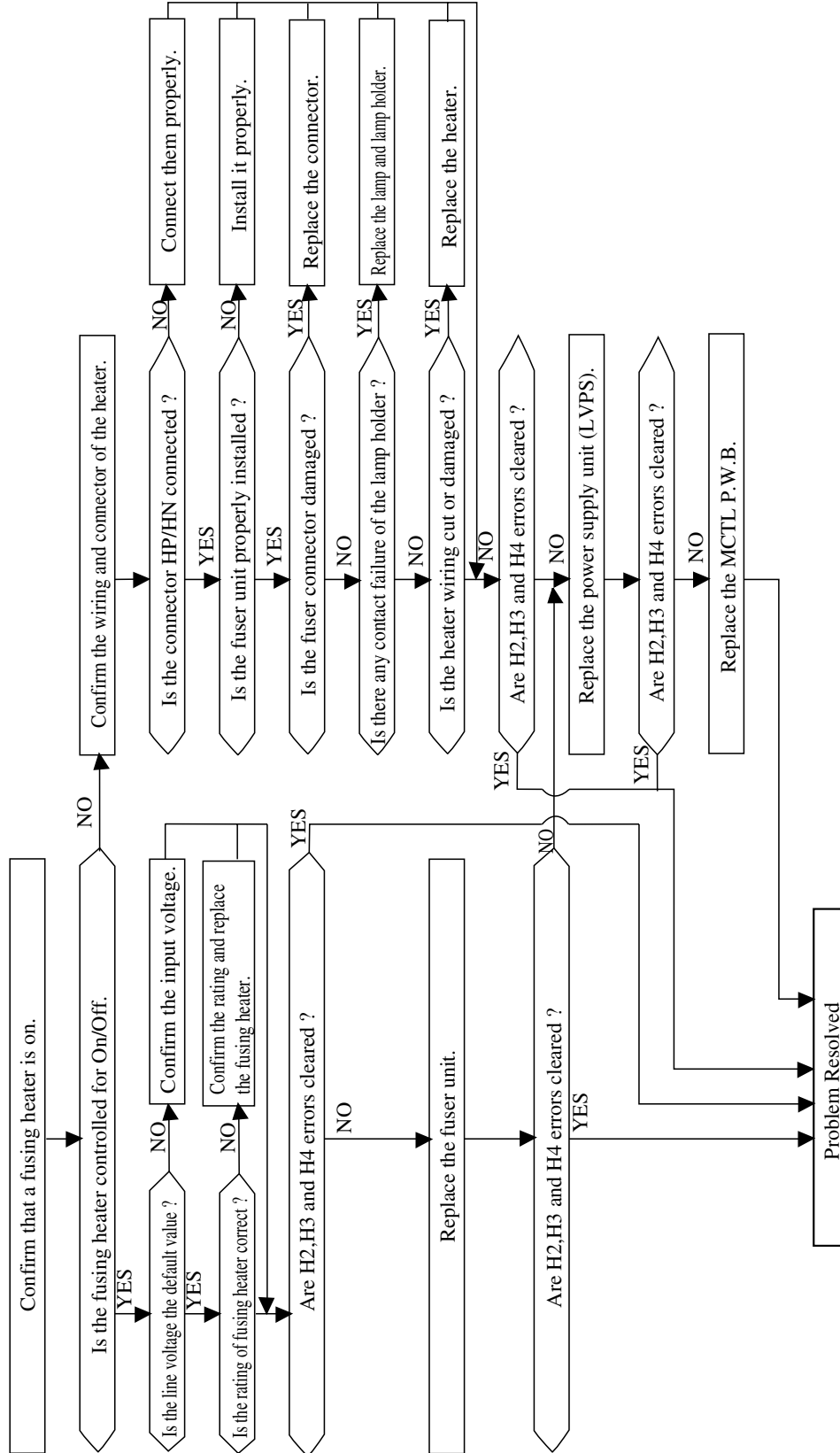

Fig. 8-52

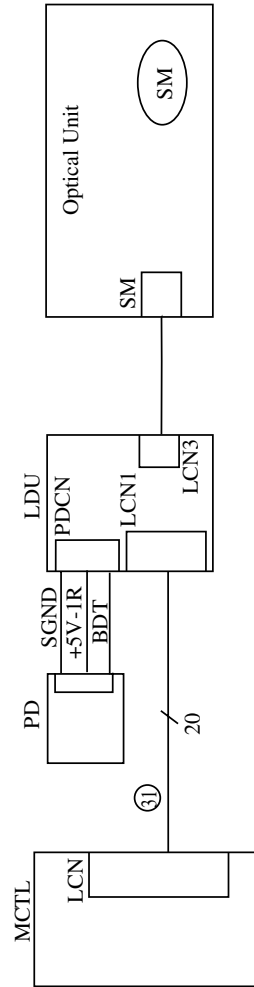
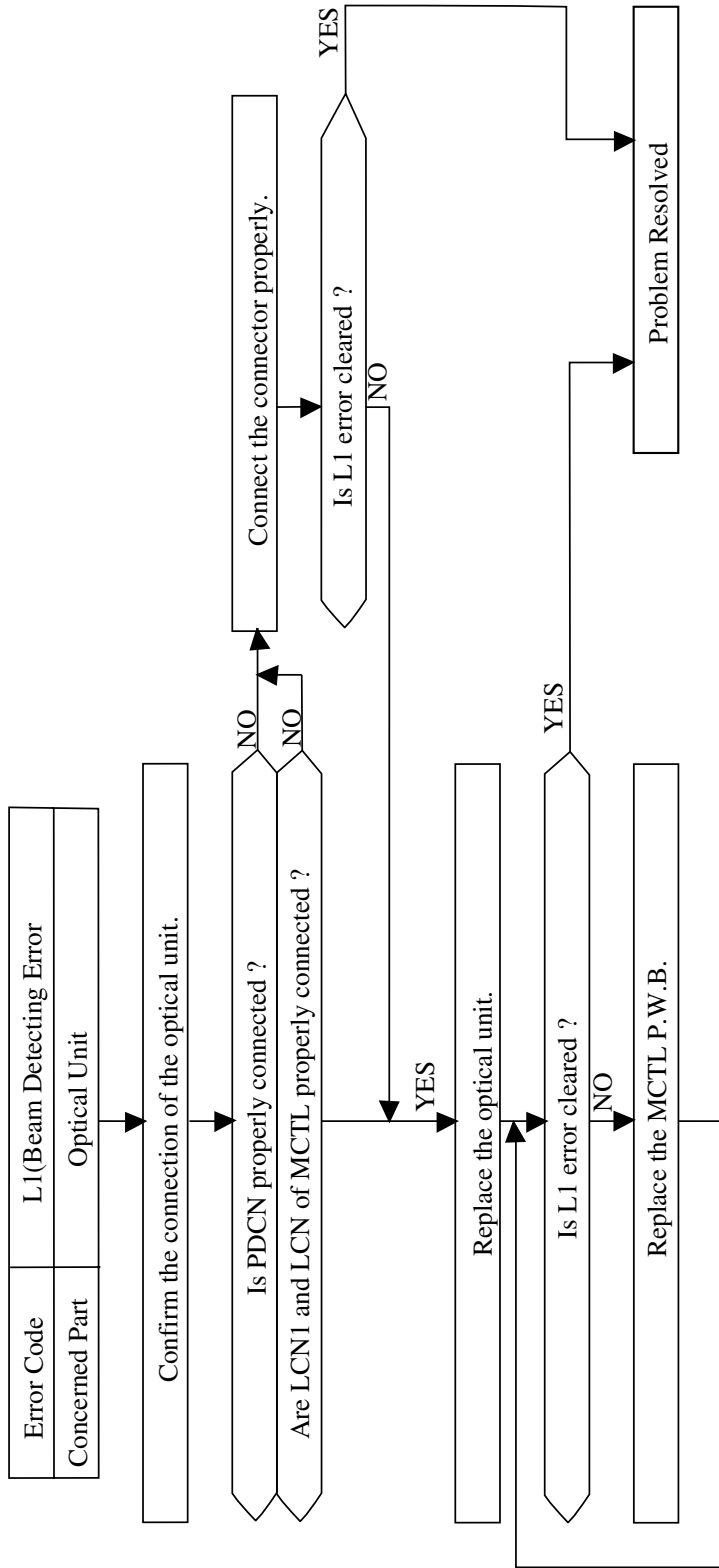

Fig. 8-53

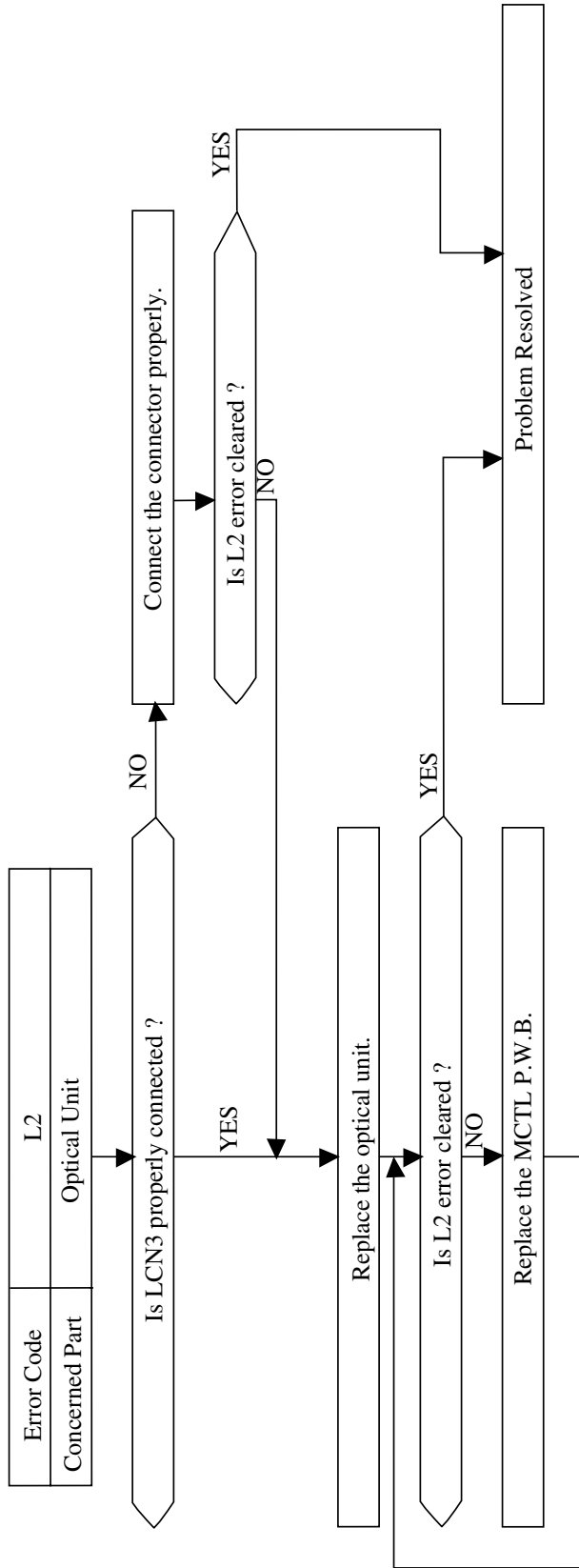
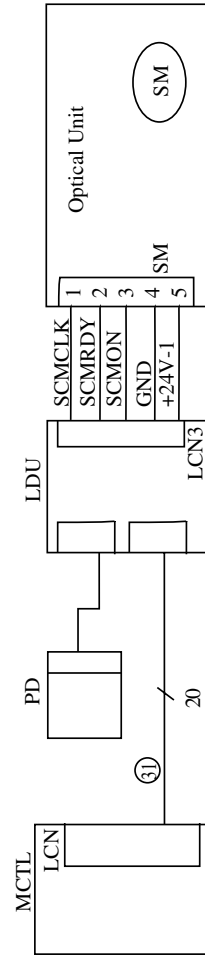

Fig. 8-54



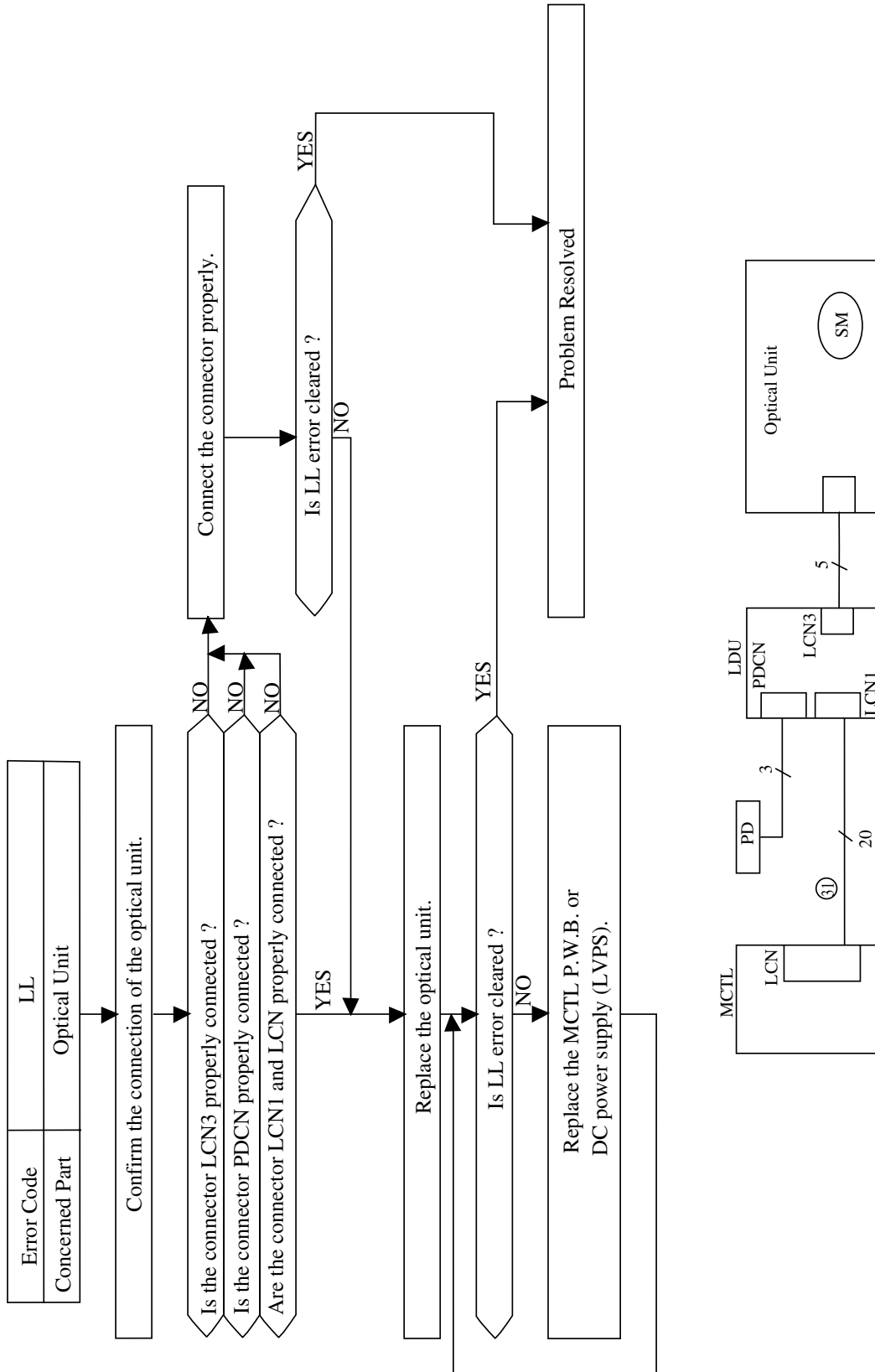

Fig. 8-55

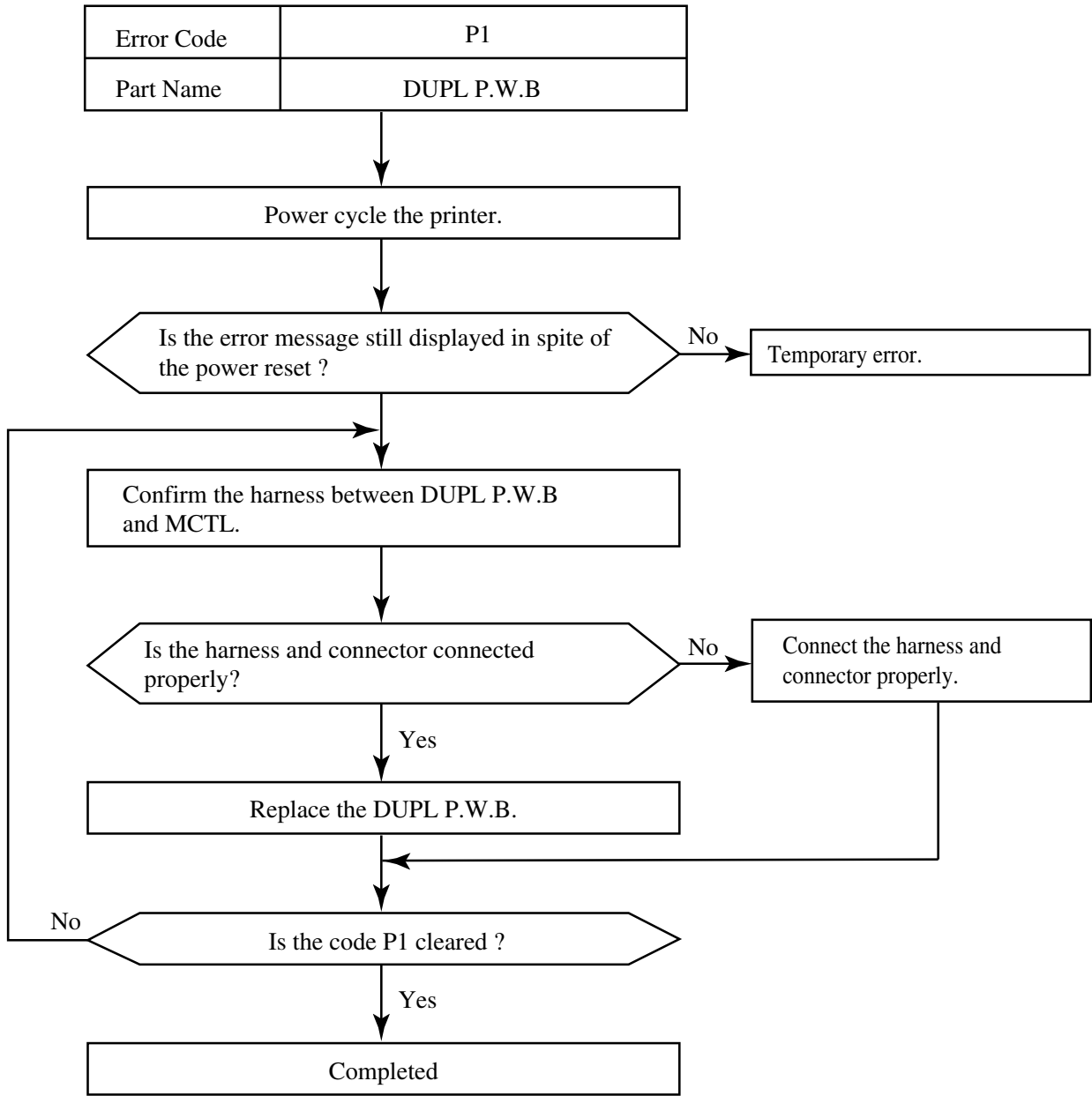

Fig. 8-56

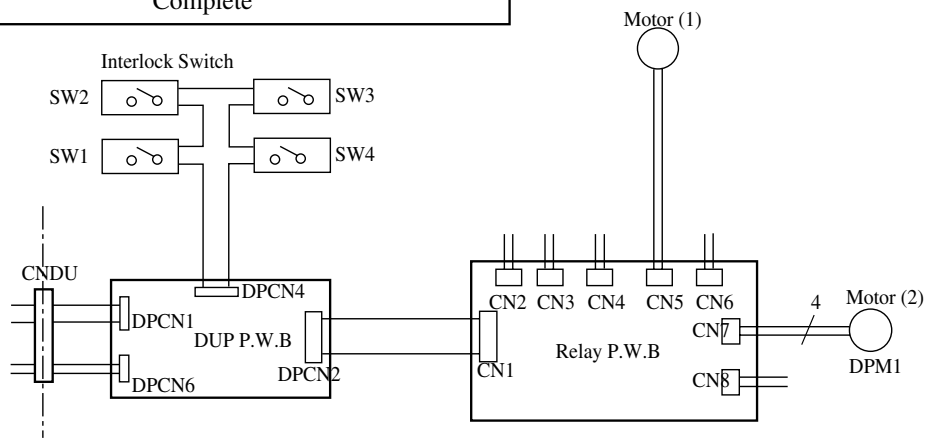
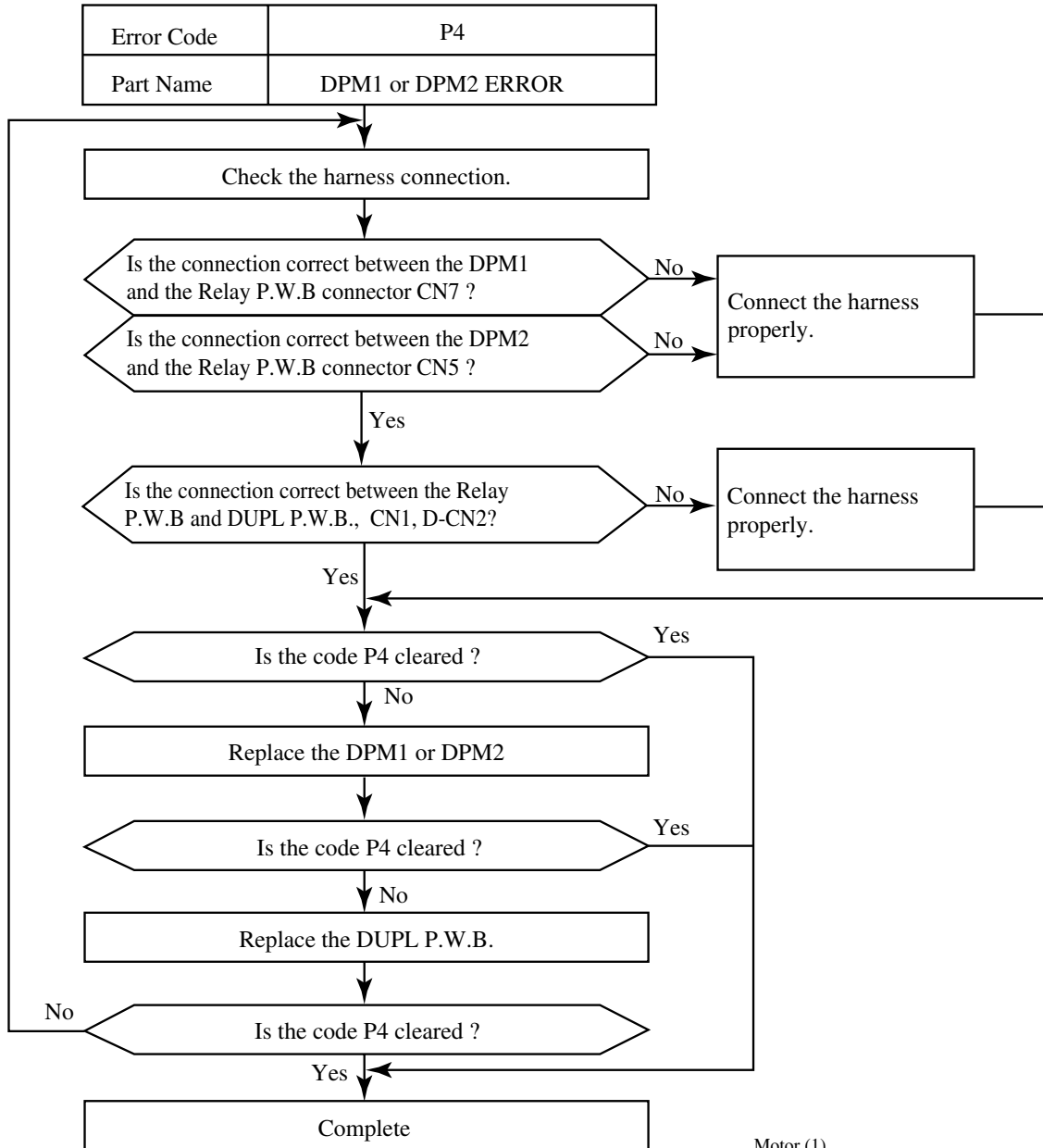

Fig. 8-57

Error Code	P3
Part Name	D-SOLENOID ERROR (L)

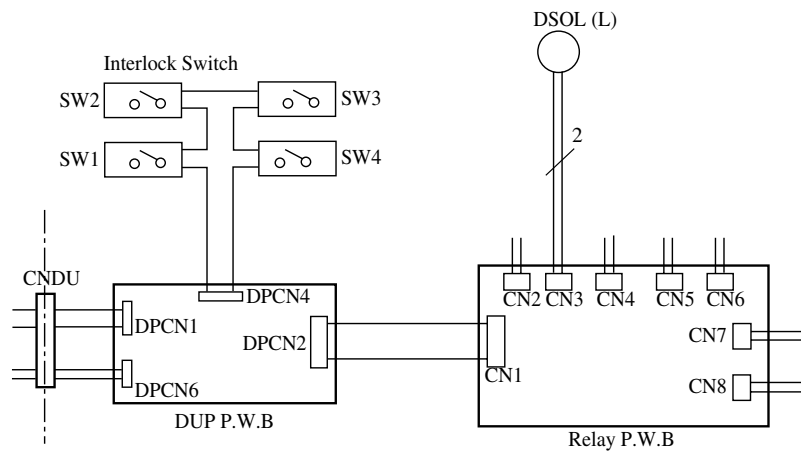
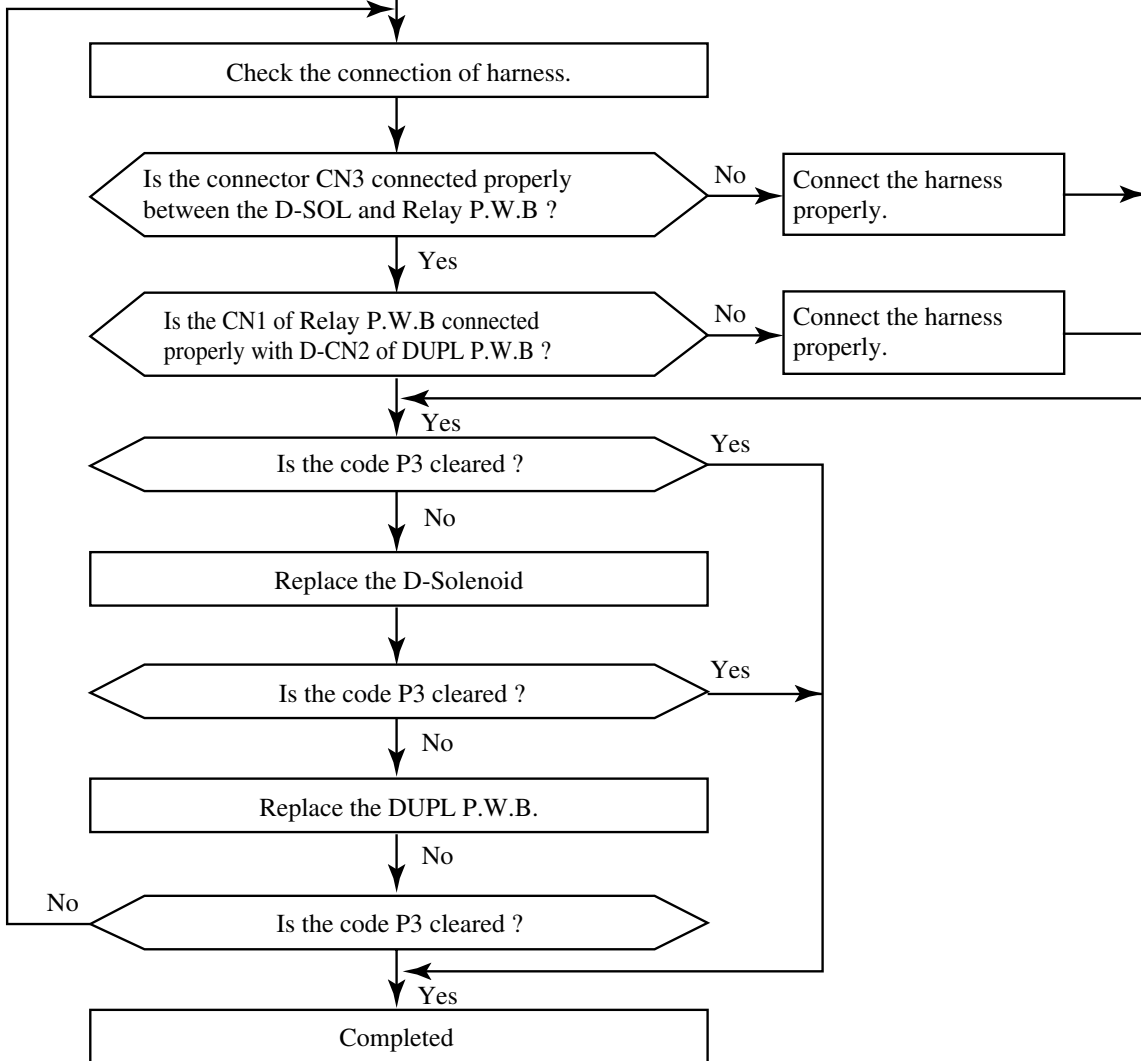

Fig. 8-58

Error Code	P5
Part Name	D-SOLENOID ERROR (U)

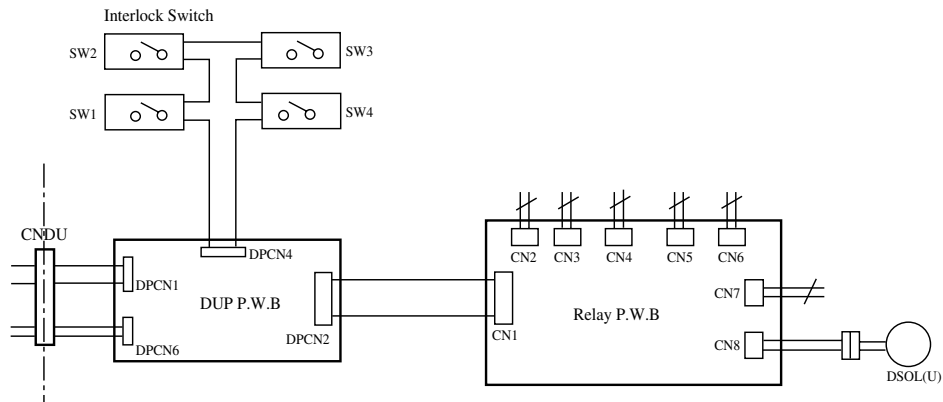
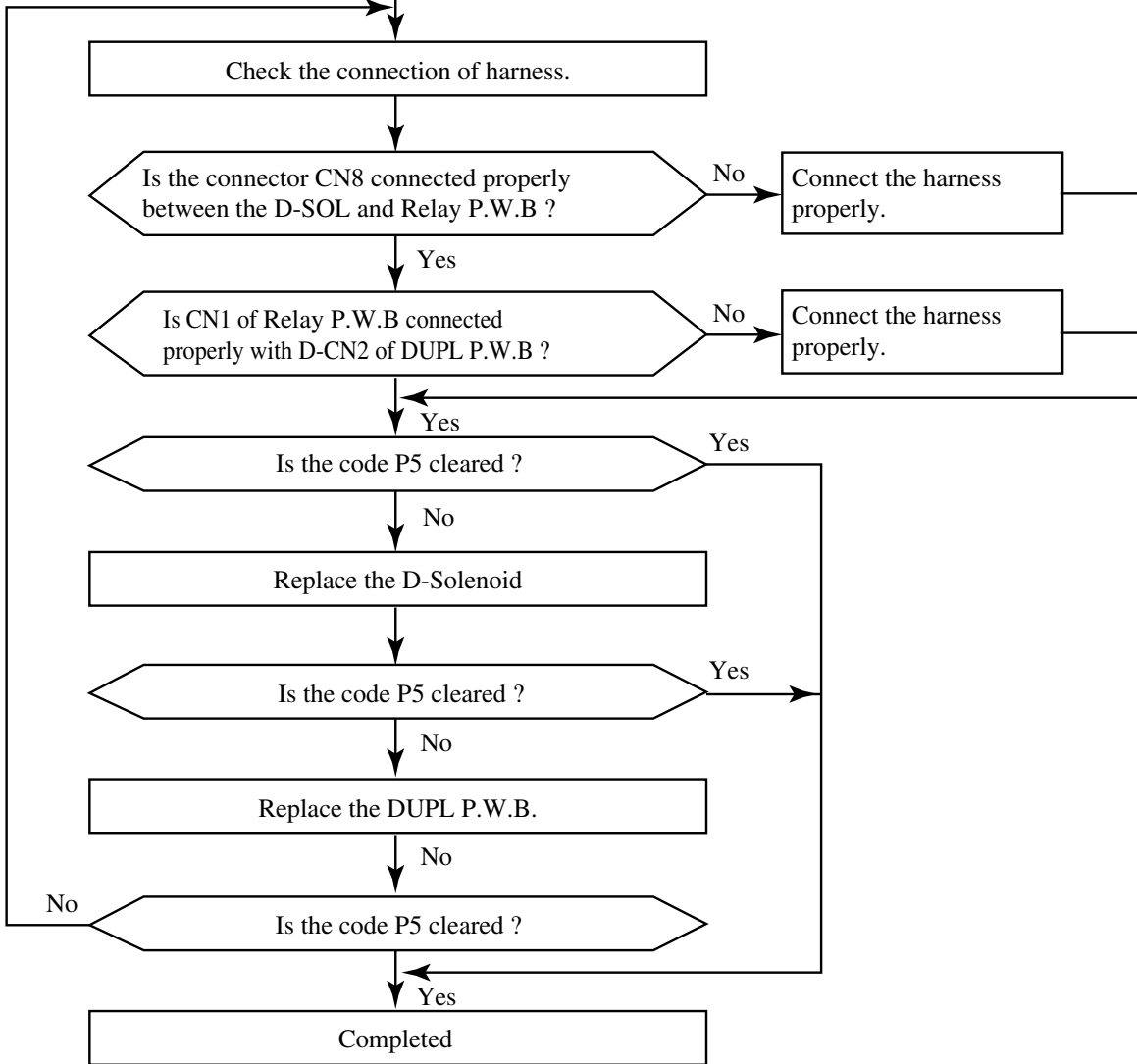

Fig. 8-59

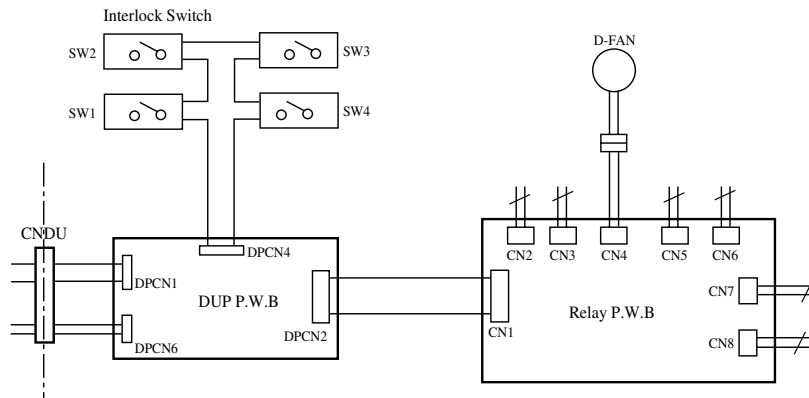
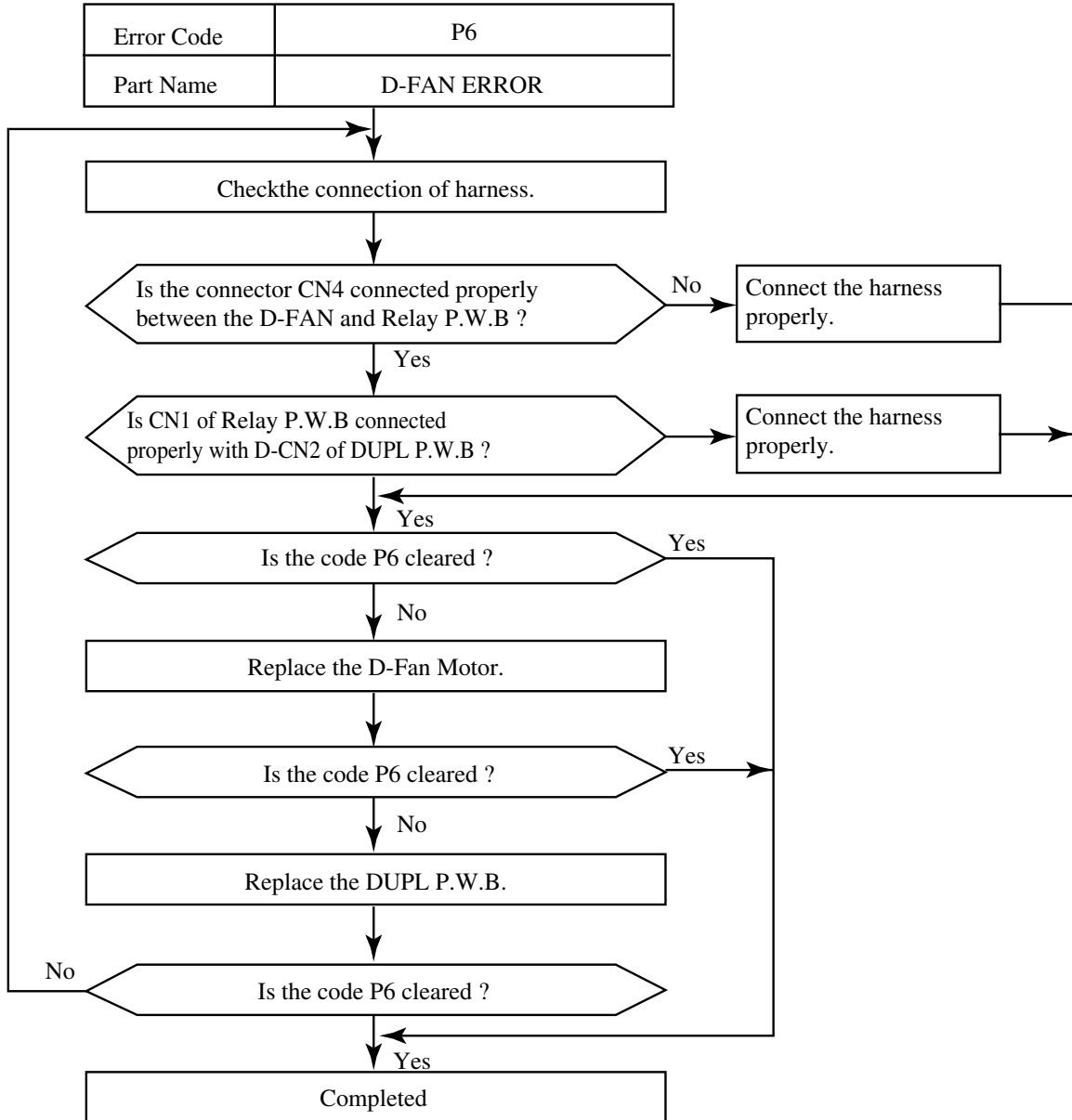

Fig. 8-60

8.5 Imaging Failures

8.5.1 Background



Fig. 8-61

8.5.1.1 Phenomenon

The background is smeared due to the toner spread as shown in the print sample at the upper-right corner.

8.5.1.2 Main Causes

1. Incorrect developer bias voltage.
2. Insufficient contact of the developer roller's bias contact.
3. Failure of the belt cartridge.
4. Failure of the high voltage power supply unit (HVU).

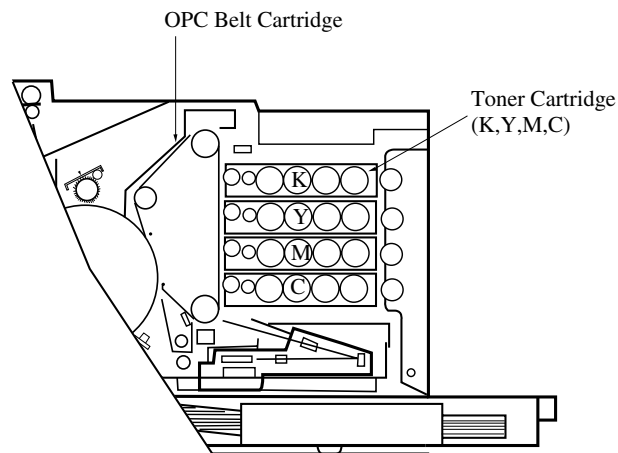
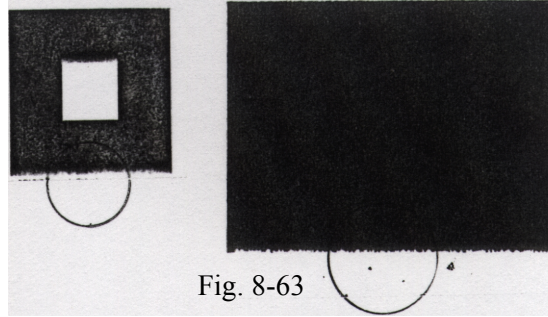

Fig. 8-62

8.5.1.3 Countermeasures

1. Replace the toner cartridge (see section 3.3.3).
2. Examine the developer bias pole to see if it is broken or deformed.
3. Replace the belt cartridge (see section 3.3.2).
4. Replace the high voltage power supply unit (HVPS) (see section 7.2.6).

8.5.2 Missing Image at Edge



8.5.2.1 Phenomenon

Missing or peeling toner particles found in the image at edge as shown in the print sample at the upper right corner.

8.5.2.2 Main Causes

1. Toner cartridge not replenishing enough toner, low developer bias voltage.
2. The OPC belt is deformed and is wavy.

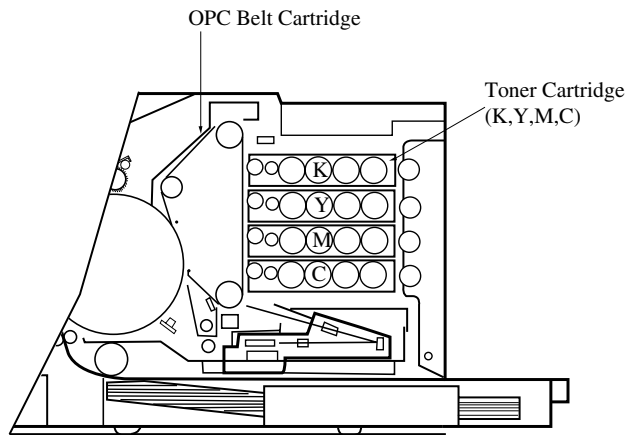

Fig. 8-64

8.5.2.3 Countermeasures

1. Replace the toner cartridge with a new toner cartridge.
2. Replace the belt cartridge with a new belt cartridge.

8.5.3 Jitter

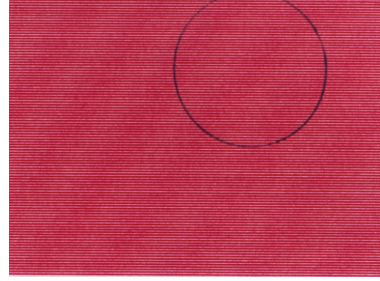

Fig. 8-65

8.5.3.1 Phenomenon

Uneven optical density appears periodically in the horizontal direction of printed image as shown in the print sample at the upper-right corner.

8.5.3.2 Main Causes

1. Failure of the main motor.
 - a. Erratic rotation of the drive motor.
 - b. Defective drive gear.
 - c. OPC belt running at irregular speeds due to above reasons.
2. Failure of the OPC belt.

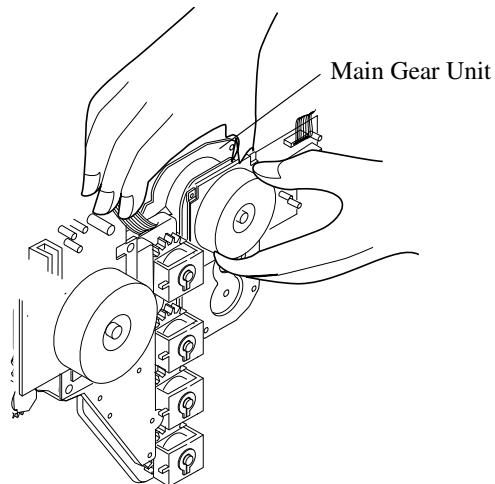

Fig. 8-66

8.5.3.3 Countermeasures

1. Replace the Main Gear Unit with a new unit (see section 7.3.2).
2. Replace the OPC belt cartridge with a new cartridge (see section 3.3.2).

8.5.4 Ribbing

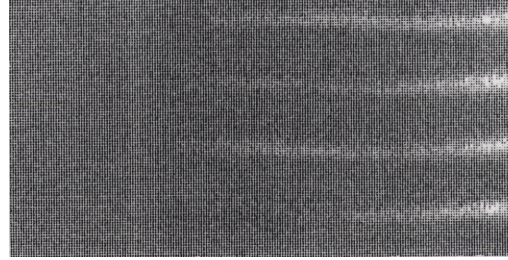

Fig. 8-67

8.5.4.1 Phenomenon

Light print occurs in the right or left side of image as shown in the print sample at the upper right-corner.

8.5.4.2 Main Causes

1. Printer not sitting on a level surface. Tilt must be $\delta 1^\circ$. A round pencil set on the surface will not roll.
2. Insufficient toner in the toner cartridge.
3. The toner cartridge is not level, and as a result, toner is concentrated on one side.
4. The spring at the back of the developer unit is deformed.
5. The front door is not completely closed.

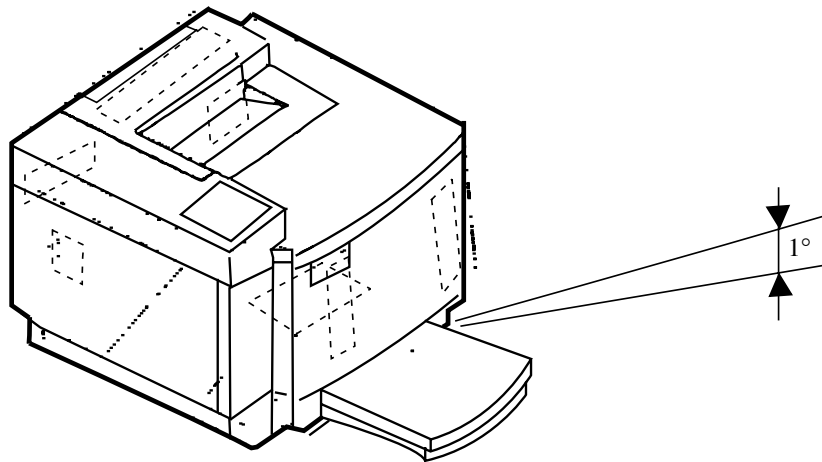

Fig. 8-68

8.5.4.3 Countermeasures

1. Confirm the printer is installed on a level surface.
2. Shake the toner cartridge horizontally several times.
3. Replace the toner cartridge with a new cartridge.
4. Inspect the open/close motion of the front door.

8.5.5 Wrinkle / Image Migration

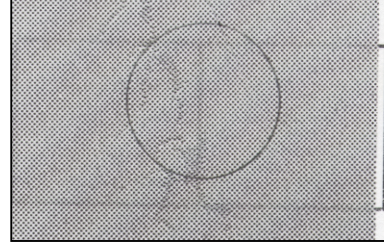

Fig. 8-69

8.5.5.1 Phenomenon

Banding shadows of different optical density appears due to wrinkle, image migration and color misregistration occurring in the image as shown in the print sample at the upper-right corner.

8.5.5.2 Main Causes

1. Paper in use is not a recommended paper; or paper is not being properly stored.
2. The paper discharger unit of transfer unit is not functioning.
3. The transfer unit is not locked properly.
4. The fuser roller is deformed or is near the end of life.
5. The fuser is not seated properly.

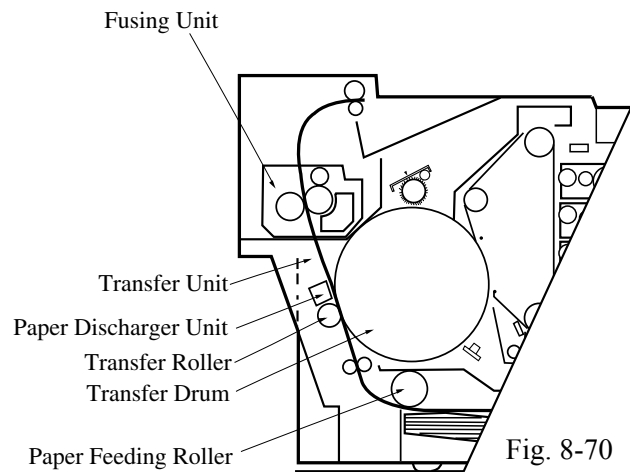

Fig. 8-70

8.5.5.3 Countermeasures

1. Use a recommended paper or a fresh ream of paper.
2. Confirm that the paper discharger unit is properly installed in the transfer unit and is functioning normally.
3. Close the transfer unit and ensure it locks at both sides.
4. Confirm that the fusing unit is mounted properly.
5. Replace the fusing unit.

8.5.6 White Line, I

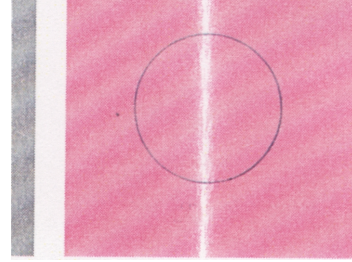

Fig. 8-71

8.5.6.1 Phenomenon

A vertical white line appears in a specific color area when test-printed in the four color mode (Stripe Mode), as shown in the print sample at the upper-right corner.

8.5.6.2 Main Causes

1. Foreign particles adhere to the Developer Roller of the specific color in question.
2. The developer Roller's surface is damaged.

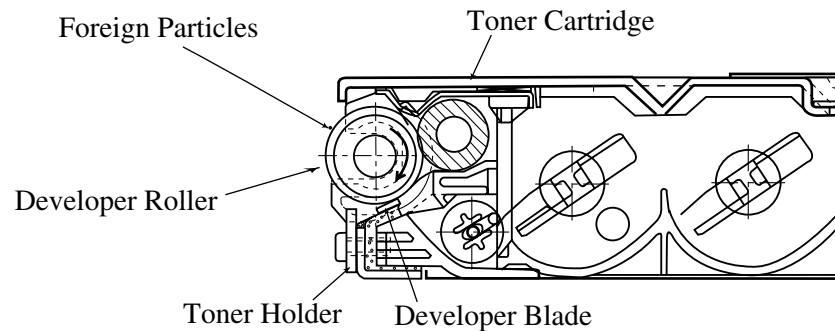

Fig. 8-72

8.5.6.3 Countermeasures

1. Print a test print.
2. Check the toner cartridge of the specific color that has caused the white line. Replace the toner cartridge, if necessary.
3. Remove the foreign particles adhering to the developer roller.

8.5.7 White Line, II

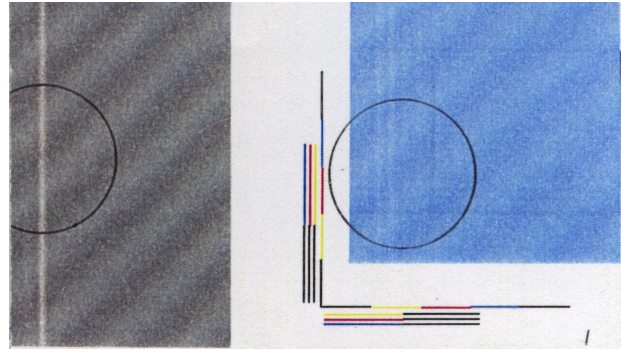

Fig. 8-73

8.5.7.1 Phenomenon

A vertical white line appears from the leading edge to the trailing edge of printed image as shown in the print sample at the upper-right corner.

8.5.7.2 Main Causes

1. The dust proof Glass in Optical Unit is smeared with toner or other foreign particles.
2. Foreign particles have adhered to the laser beam opening of the optical unit.
3. There are foreign particles mixed in the toner cartridge.

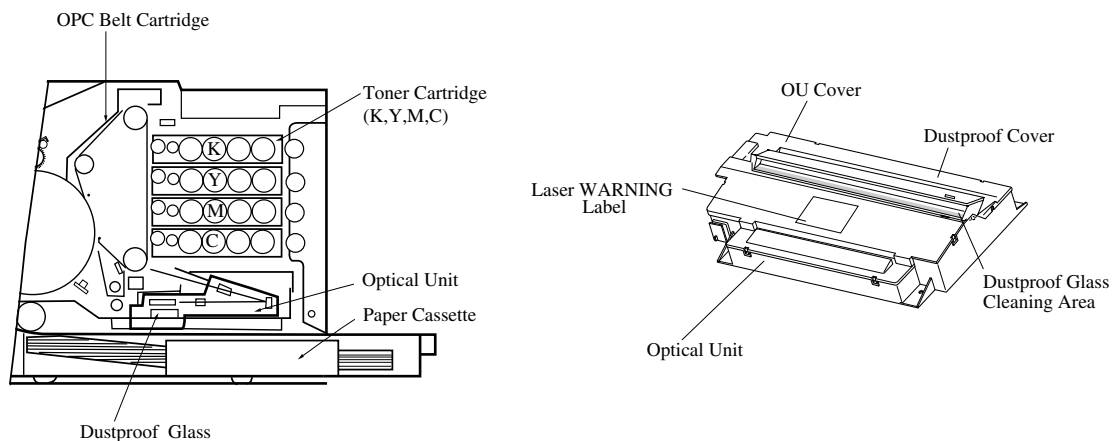

Fig. 8-74

8.5.7.3 Countermeasures

1. If White Line II, failure is attributed to a toner cartridge, then replace it with a new cartridge.
2. Clean the dust proof glass.
3. Remove the toner cartridges and belt cartridge (see section 3.3.3 and section 3.3.2).
4. Clean the dust proof glass (see section 5.2.2.6).

8.5.8 Vertical White Band

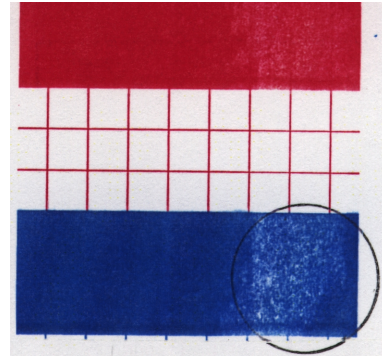

Fig. 8-75

8.5.8.1 Phenomenon

A white band appears in the vertical direction of printed image as shown in the print sample at the upper-right corner.

8.5.8.2 Main Cause

1. Silicone oil on the transfer drum.

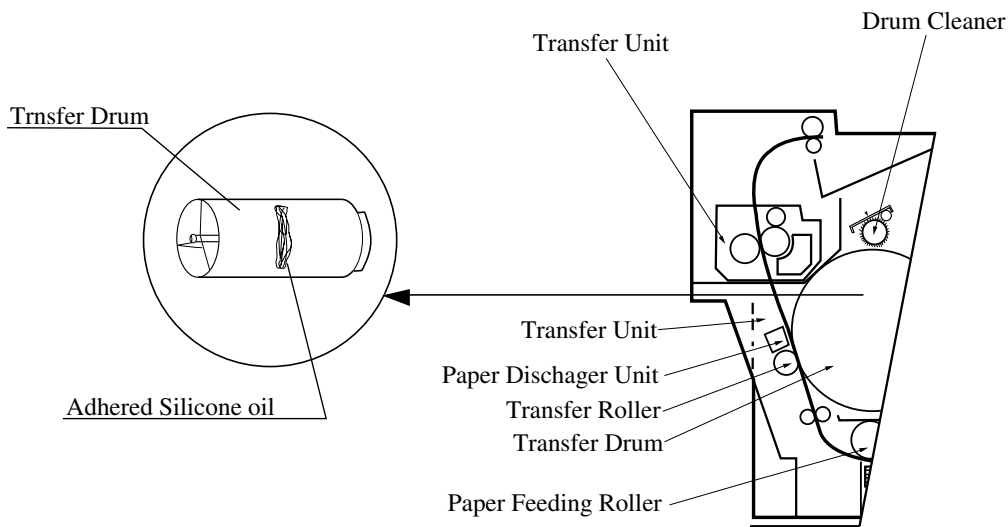

Fig. 8-76

8.5.8.3 Countermeasures

1. Wipe off any oil on or around the transfer unit.
2. Replace the transfer drum (see section 7.6.3).
3. If the oil adhesion is excessive, replace the belt cartridge, cleaning brush, and toner cartridge.

8.5.9 Black Line

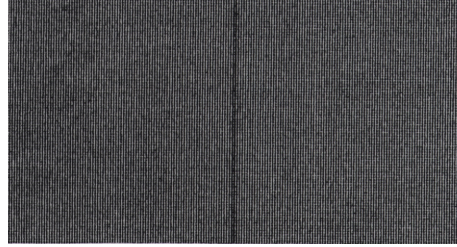

Fig. 8-77

8.5.9.1 Phenomenon

A fine black line appears in the printed image as shown in the print sample at the upper-right corner.

8.5.9.2 Main Causes

1. The corona wire in the charger unit is contaminated.
2. The OPC belt surface is damaged.
3. Foreign particles (paper dust, etc.) are stuck in between the cleaning blade and OPC belt.
4. Debris adhering to the base of toner cartridge's developer roller contacts the OPC belt.

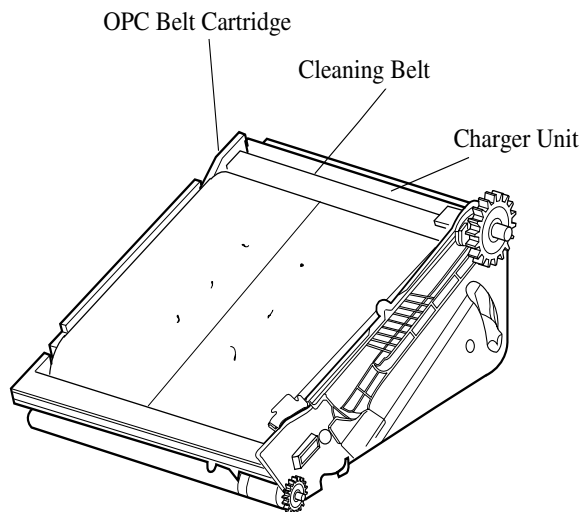

Fig. 8-78

8.5.9.3 Countermeasures

1. Remove the belt cartridge and clean the charger unit on the OPC.
2. Remove any particles adhering to the surface of developer roller.
3. Replace the belt cartridge with a new cartridge if steps 1 and 2 do not resolve the problem.

8.5.10 Vertical Line

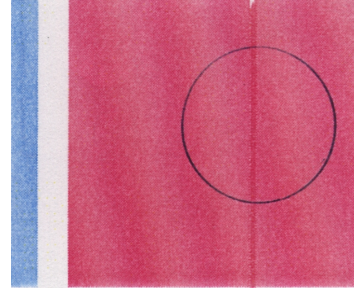

Fig. 8-79

8.5.10.1 Phenomenon

A vertical line appears in the printed image as shown in the print sample at the upper-right corner.

8.5.10.2 Main Causes

1. Foreign particles (dust, etc.) adhere to the parts located around the transfer drum, and contact the toner image on the transfer drum.

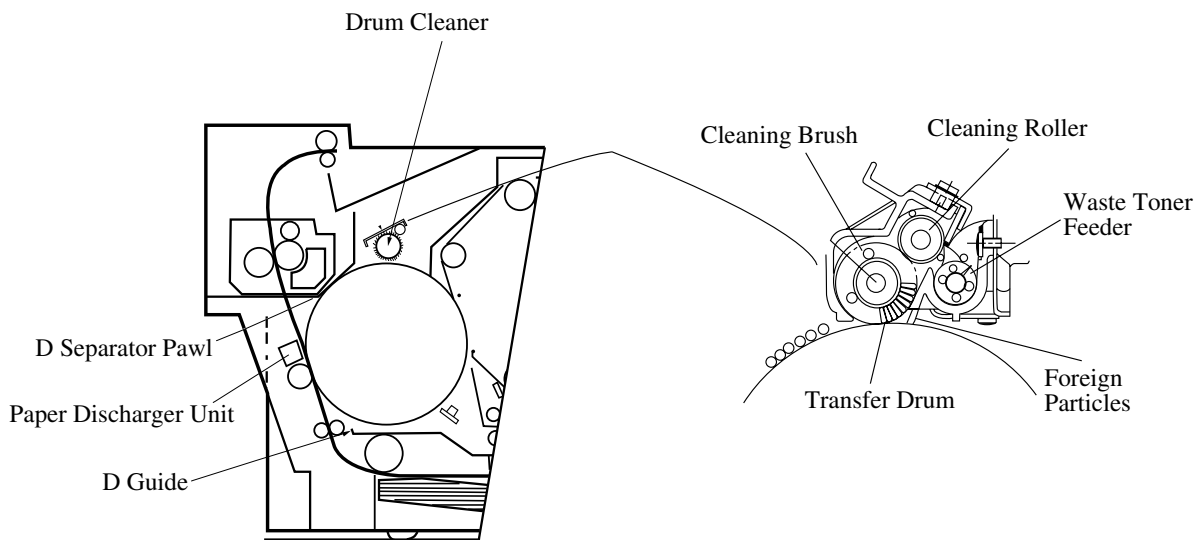

Fig. 8-80

8.5.10.3 Countermeasures

1. Clean the paper discharger unit (see section 5.3.5.4.1).
2. Clean the D guide and D separator pawl.
3. Remove and vacuum the drum cleaner.

8.5.11 Vertical Staggering Image

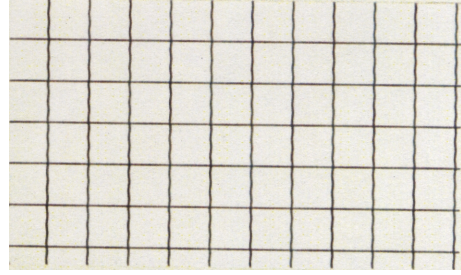

Fig. 8-81

8.5.11.1 Phenomenon

The printed image staggers in the vertical direction as shown in the print sample at the upper right corner.

8.5.11.2 Main Causes

1. The printer is located on an unstable surface.
2. The optical unit failure caused by vibration of the scanner motor.

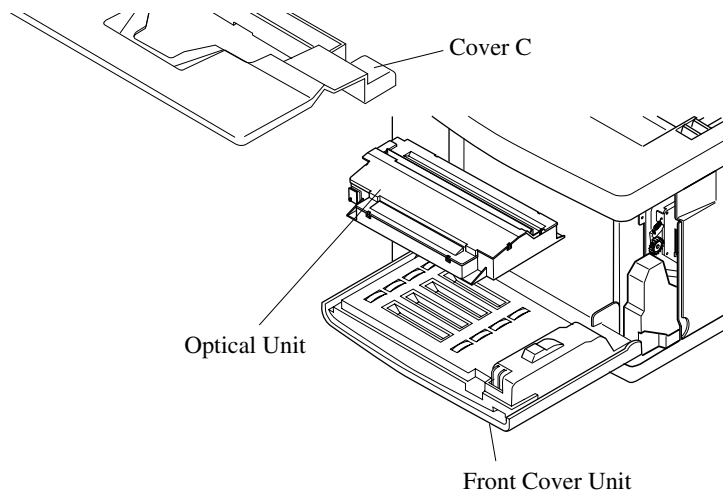

Fig. 8-82

8.5.11.3 Countermeasures

1. Do not apply shock or vibration to the printer.
2. The surface on which the printer is placed should be stable.
3. Replace the optical unit (see section 7.3.5).

8.5.12 Banding

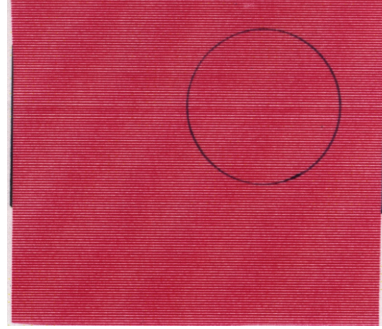

Fig. 8-83

8.5.12.1 Phenomenon

Banding line appears in the horizontal direction as shown in the print sample at the upper-right corner.

8.5.12.2 Main Causes

1. This is a transfer failure due to the uneven rotational speed caused by the shock which occurs when the seam of OPC belt passes over the cleaning blade.

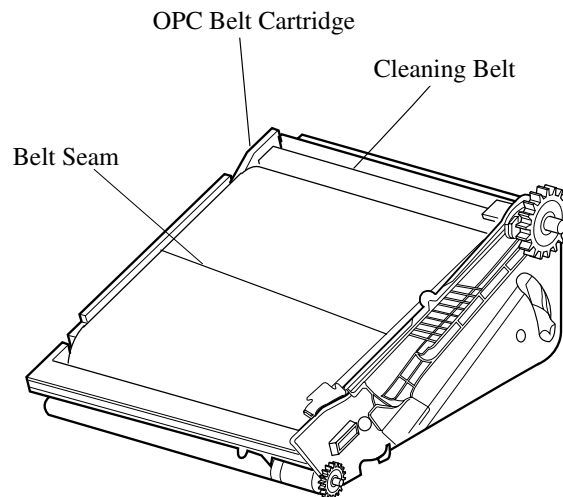

Fig. 8-84

8.5.12.3 Countermeasures

1. Replace the belt cartridge (see section 5.3.2).

8.5.13 White Band

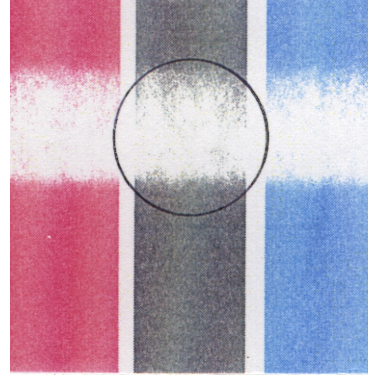

Fig. 8-85

8.5.13.1 Phenomenon

A white banding line appears in the horizontal direction, and consequently causes a missing image as shown in the print sample at the upper-right corner.

8.5.13.2 Main Causes

1. The transfer unit not properly installed or there is a bad transfer roller.
2. Failure of the transfer roller's contacts.
3. TR Cam Clutch failure.

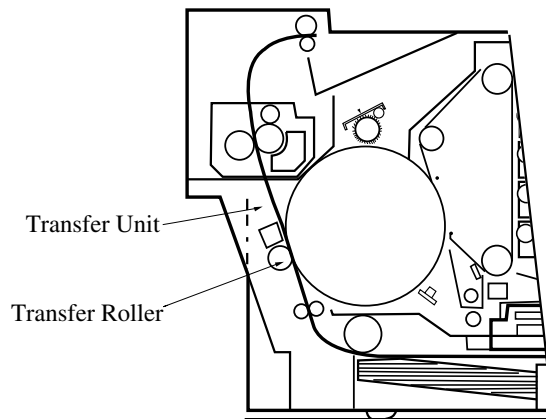

Fig. 8-86

8.5.13.3 Countermeasures

1. Check that the transfer unit is mounted properly, and that both sides of the transfer unit are fixed by hooks.
2. Replace the TR cam clutch with a new clutch (see section 7.4).
3. Replace the transfer unit (see section 7.6.1).

8.5.14 Toner Drop

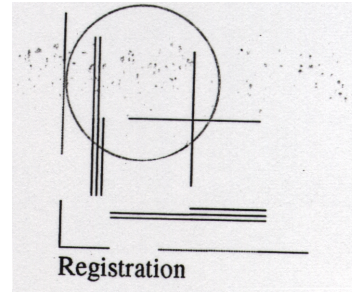

Fig. 8-87

8.5.14.1 Phenomenon

Toner stain on the image is caused by loose toner in the printer as shown in the print sample at the upper-right corner.

8.5.14.2 Main Causes

1. Toner stain on the transfer drum is due to the breakdown of the waste toner feeder from the drum cleaner.
 - a. Mylar in the waste toner feeder is deformed.
 - b. Waste toner is not being collected by the waste toner feeder.
2. Toner adhering to the developer roller drops onto the OPC belt.

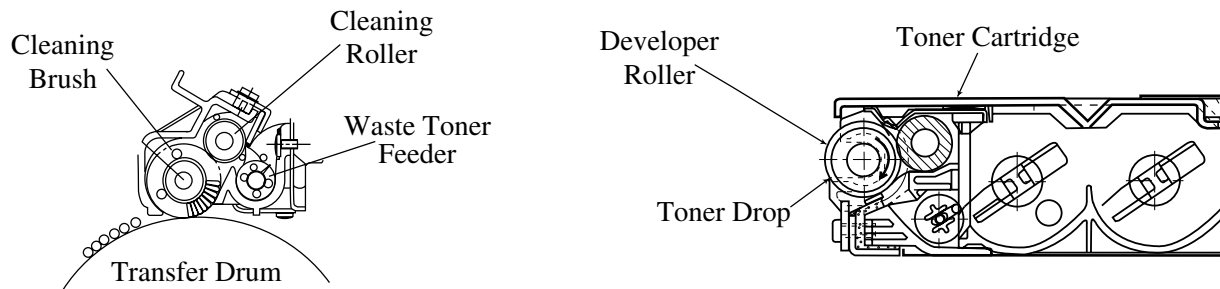

Fig. 8-88

8.5.14.3 Countermeasures

1. Examine the cleaning brush and waste toner feeder.
 - a. Clean the area of the cleaning brush.
 - b. Check if the seal is deformed or damaged. If any deformation or damage, replace the waste toner feeder with a new feeder.
 - c. Check for blockage in the waste toner auger. Vacuum and remove the excess waste tone.
2. Remove and clean the toner cartridge.
3. Replace the belt cartridge with a new cartridge if steps 1 and 2 do not resolve the problem.

8.5.15 White Spot / Black Spot

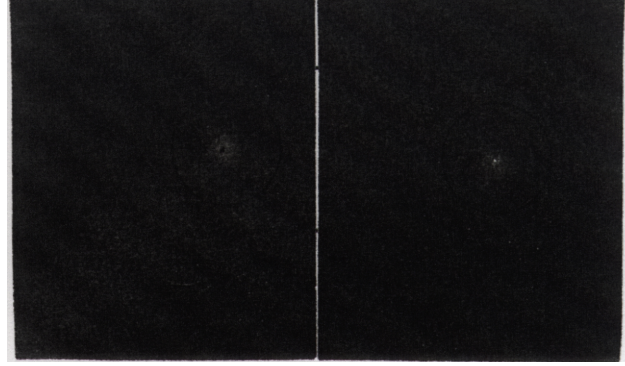

Fig. 8-89

8.5.15.1 Phenomenon

A white or black spot appears on the image as shown in the print sample at the upper-right corner.

8.5.15.2 Main Causes

1. Foreign particles adhering to the OPC belt or transfer drum.
2. The OPC belt or transfer drum is damaged.
3. Foreign particles mixed into the toner.
4. Foreign particles adhering to the transfer roller, or deformation of transfer roller.

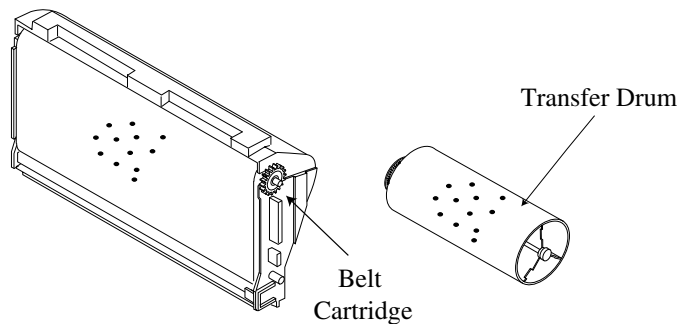

Fig. 8-90

8.5.15.3 Countermeasures

1. Remove the belt cartridge and lightly wipe off any foreign particles adhering to OPC belt, using lint free cloth.
2. Replace the damaged belt cartridge with a new cartridge.
3. Open the transfer unit, and check the transfer drum.
4. Lightly wipe off the foreign particles adhering to transfer drum, using a lint free cloth.
5. Replace the damaged transfer drum with a new drum (see section 7.6.3).
6. Replace the toner cartridge with a new cartridge (see section 3.3.3).
7. Replace the transfer unit with a new unit (see section 7.6.1).

8.5.16 Mixed Color Image

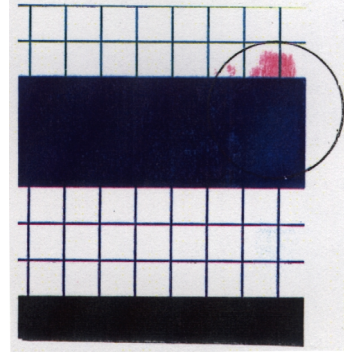

Fig. 8-91

8.5.16.1 Phenomenon

A mixed color image appears in the image as shown in the print sample at the upper-right corner.

8.5.16.2 Main Causes

1. Failure of a toner cartridge: Blade pressure of the developer roller is inappropriate or the blade is deformed.
2. Defective toner cartridge.

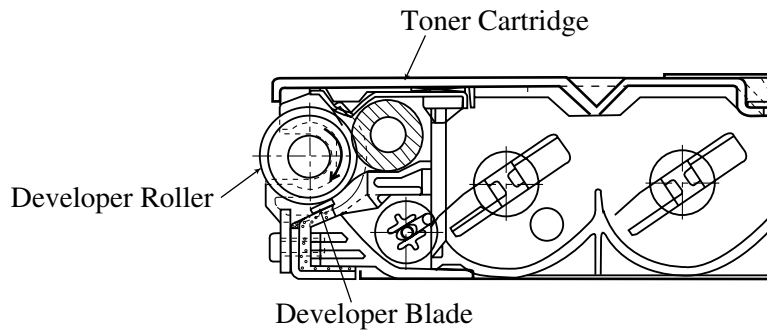

Fig. 8-92

8.5.16.3 Countermeasures

1. Confirm that the toner cartridge can be inserted smoothly.
2. Replace the toner cartridge.

8.5.17 Color Misregistration

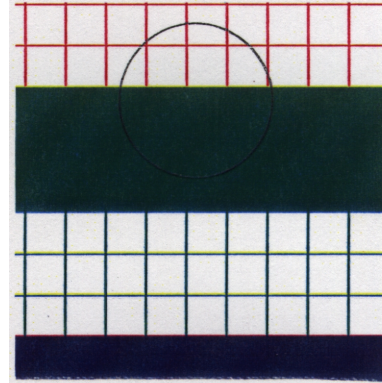

Fig. 8-93

8.5.17.1 Phenomenon

Color misregistration is caused between two colors as shown in the print sample at the upper-right corner.

8.5.17.2 Main Causes

1. The OPC belt cartridge is not properly installed.
2. The OPC belt cartridge is defective.
3. The cleaning brush is not installed properly, or cleaning brush is defective.
4. The OPC belt cartridge is binding.

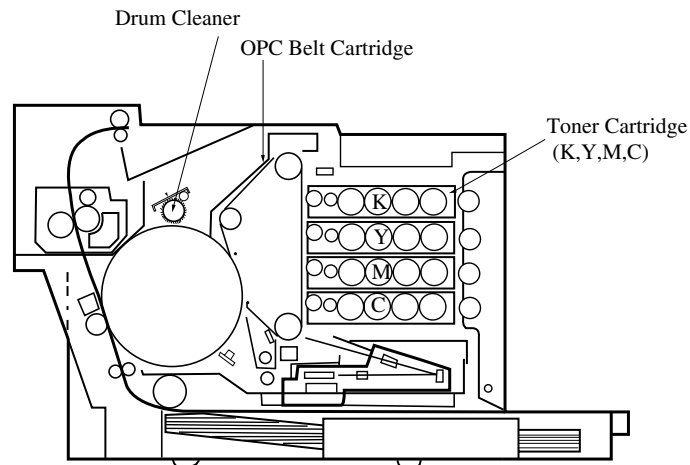

Fig. 8-94

8.5.17.3 Countermeasures

1. Reseat the OPC belt cartridge properly.
2. Replace the OPC belt cartridge with a new cartridge.
3. Replace the cleaning brush with a new brush.
4. Replace the Drum Cleaner solenoid.

8.5.18 Mottle

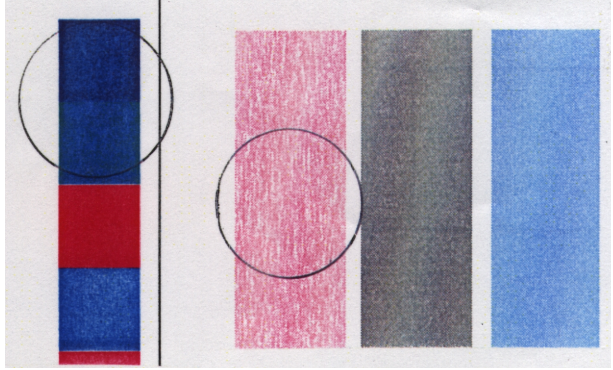

Fig. 8-95

8.5.18.1 Phenomenon

Variation of the optical density is found in the image as shown in the print sample at the upper-right corner.

8.5.18.2 Main Causes

1. The transfer unit is not properly installed.
2. The transfer roller is not properly installed.
3. THV output of the High Voltage Power Supply is incorrect.
4. Failure of the toner cartridge.
5. Defective or environmentally affected paper.

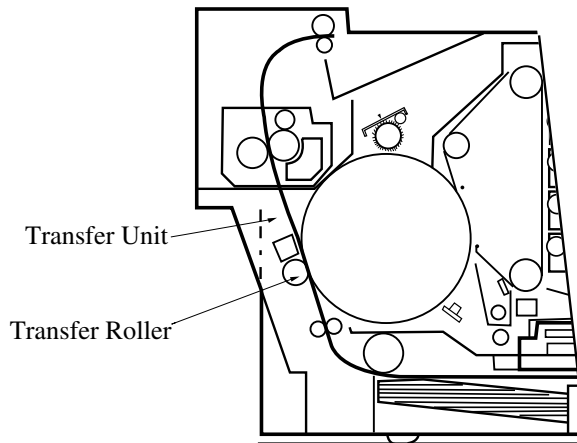

Fig. 8-96

8.5.18.3 Countermeasures

1. Replace the paper.
2. Confirm if the transfer unit is firmly locked.
3. Confirm if the transfer roller is properly installed.
4. Replace the toner cartridge.
5. Replace the high voltage power supply with a new unit (see section 7.2.6).

8.5.19 Residual Image

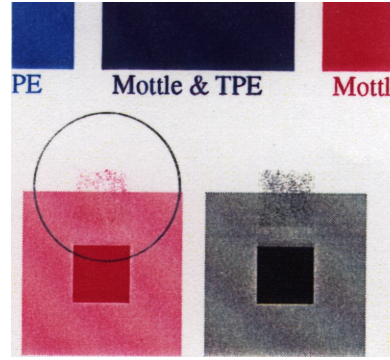

Fig. 8-97

8.5.19.1 Phenomenon

The image of the preceding page appears on following pages as shown in the print sample at the upper-right corner.

8.5.19.2 Main Causes

1. Cleaning failure due to improperly installed drum cleaner.
2. Contact failure of the drum cleaner's contacts.
3. Failure of High Voltage Power Supply.

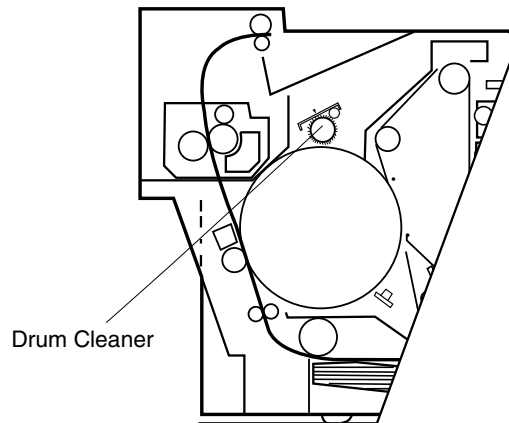

Fig. 8-98

8.5.19.3 Countermeasures

1. Check if the drum cleaner is properly installed.
2. Replace the failed High Voltage Power Supply (see section 7.2.6).

8.5.20 Insufficient Gloss

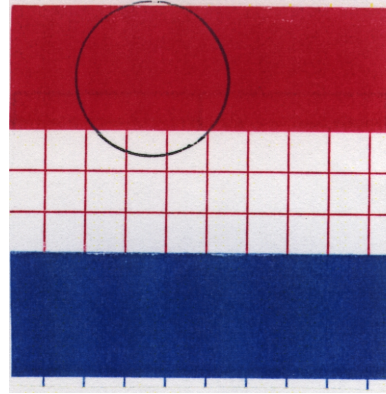

Fig. 8-99

8.5.20.1 Phenomenon

Gloss of the print is not sufficient as shown in the print sample at the upper-right corner.

8.5.20.2 Main Causes

1. Cleaning roller is stained.
2. Fuser roller is deteriorated.

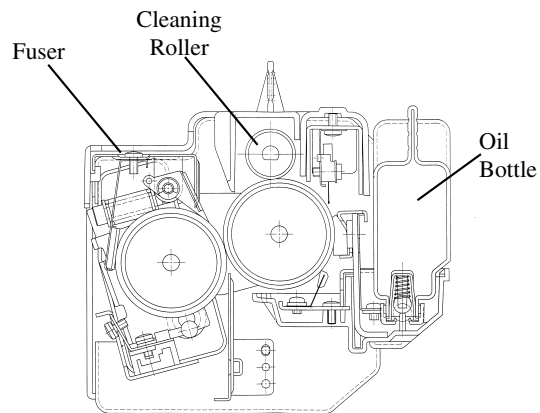

Fig. 8-100

8.5.20.3 Countermeasures

1. Replace the cleaning roller (see section 3.3.1).
2. Replace the fuser unit (see section 5.3.3).

8.5.21 Back Stain

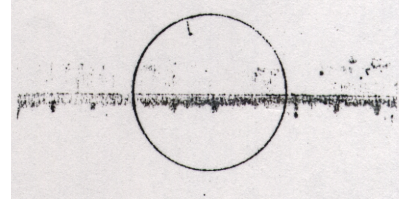

Fig. 8-101

8.5.21.1 Phenomenon

The back side of the paper is stained as shown in the print sample in the upper-right corner.

8.5.21.2 Main Causes

1. The fuser cleaning pad is stained.
2. The silicone oil is low.
3. The fuser roller and back-up roller are stained.

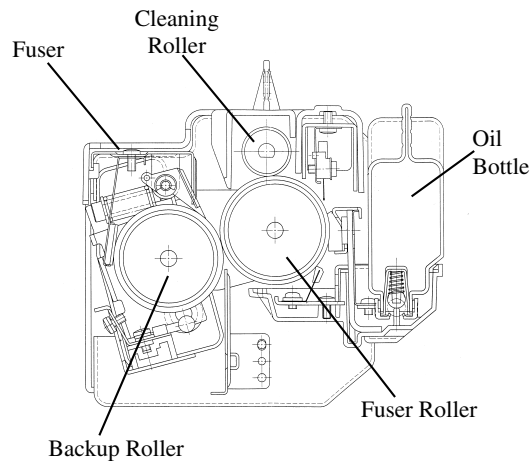
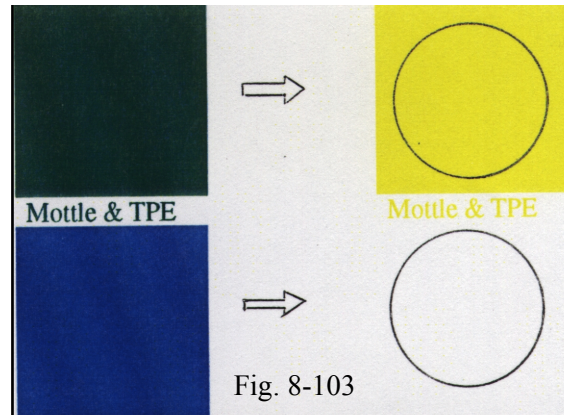

Fig. 8-102

8.5.21.3 Countermeasures

1. Replace fuser oil bottle.
2. Clean the fuser roller and back-up roller.
3. Replace the cleaning roller (see section 3.3.1).
4. Replace the fuser unit with a new unit (see section 5.3.3).

8.5.22 White Print



8.5.22.1 Phenomenon

A blank page is ejected (no print at all) or a specific color is missing (not printed) as shown in the print sample at the upper-right corner.

8.5.22.2 Main Causes

1. The laser light path is blocked by paper or other material stuck at the opening of the optical unit.
2. The transfer Solenoid is defective.
3. There is no OPC belt bias voltage.
4. There is no output from the high voltage power supply (HVPS).

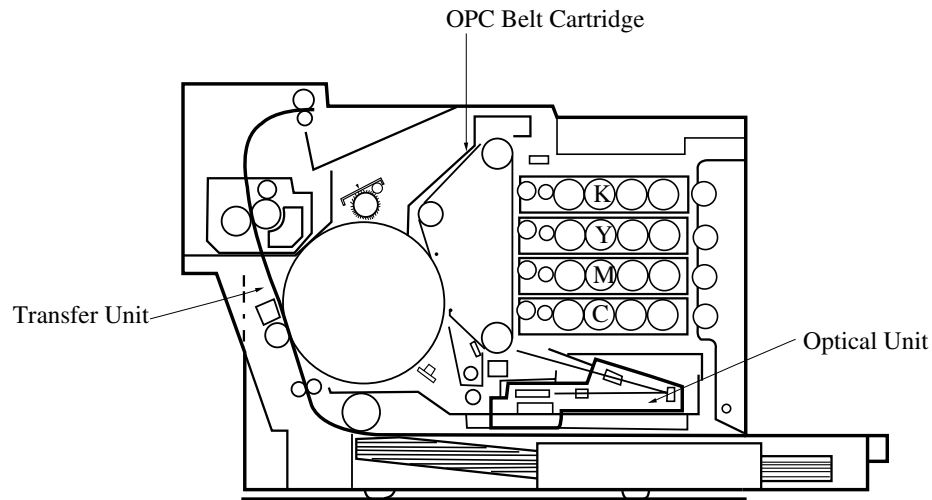

Fig. 8-104

8.5.22.3 Countermeasures

1. Confirm that no foreign particles are stuck at the opening of optical unit.
2. Replace the transfer solenoid (see section 7.8.5.2).
3. Replace the belt cartridge.
4. Replace the high voltage power supply (HVPS) (see section 7.2.6).

8.5.23 Insufficient Fusing

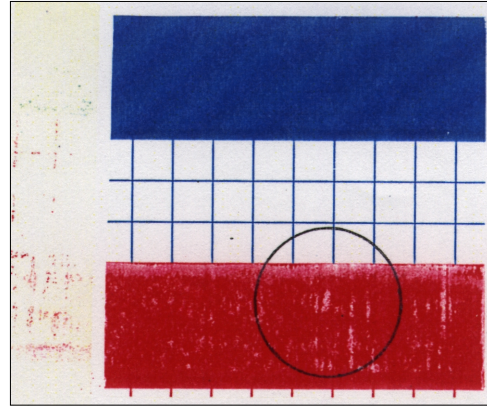

Fig. 8-105

8.5.23.1 Phenomenon

The printed image is partially missing as shown in the print sample at the upper-right corner.

8.5.23.2 Main Causes

1. The user selects the wrong type of media (e.g., thick stock) either on the host or at the control panel of the printer.
2. Recommended paper is not used.
3. Failure of the fuser unit.

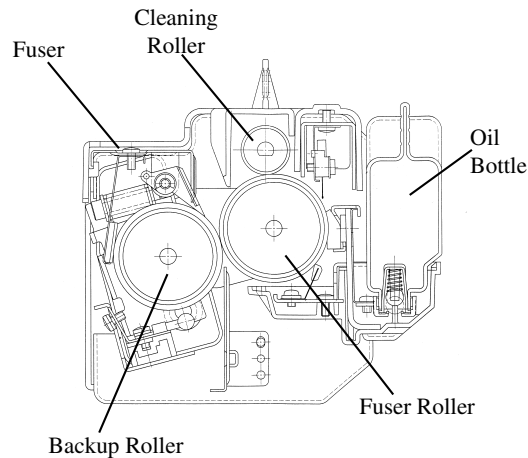

Fig. 8-106

8.5.23.3 Countermeasures

1. Adjust the mode on the host side or the control panel to match the print media used.
2. Use the recommended paper.
3. Replace the fuser unit.

Section 9:
Spare Parts Breakdown

9.0 Spare Parts Breakdown

Table 9-1: Spare Parts List (Consumables and Supplies)

Ref. Number ^a	Part Name	Part Number	Remarks
1	Toner Cartridge, Yellow	1710362-004	8,500 images
2	Toner Cartridge, Magenta	1710362-003	8,500 images
3	Toner Cartridge, Cyan	1710362-002	8,500 images
4	Toner Cartridge, Black	1710362-001	14,000 images
5	OPC Belt Cartridge	1710365-001	12,000 images
6	Fuser Oil	1710367-001	12,000 pages
7	Cleaning Roller, Fuser	1710367-001	200,000 images
8	Waste Toner Bottle	1710368-001	18,000 images
9	Fuser (US)	825126619	100,000 pages
10	Fuser (EC)	825126620	100,000 pages
11	Fuser (JP)	825126621	100,000 pages
12	Transfer Roller	825126627	240,000 pages
13	Paper Discharger	825126628	240,000 pages
14	Drum Cleaner	825126630	240,000 pages
15	Ozone Filter	825126164	1 per year
16	Power Cord (US)	825126148	
17	Power Cord (JP)	NA	
18	Paper Cassette	825126636	
19	Cleaner Cover	825126657	
20	Transfer Unit Door Cover	825126626	
21	Transfer Unit	825126625	
22	Envelope Adaptor	1710389-001	
23	Controller (Crown)	2293279-901	
	Controller (DeskLaser)	2293282-901	

a. See Fig. 9-1 for an illustration of these parts.

Fig. 9-1 Diagram for Consumables and Supplies
(See Table 9-1 for part numbers)

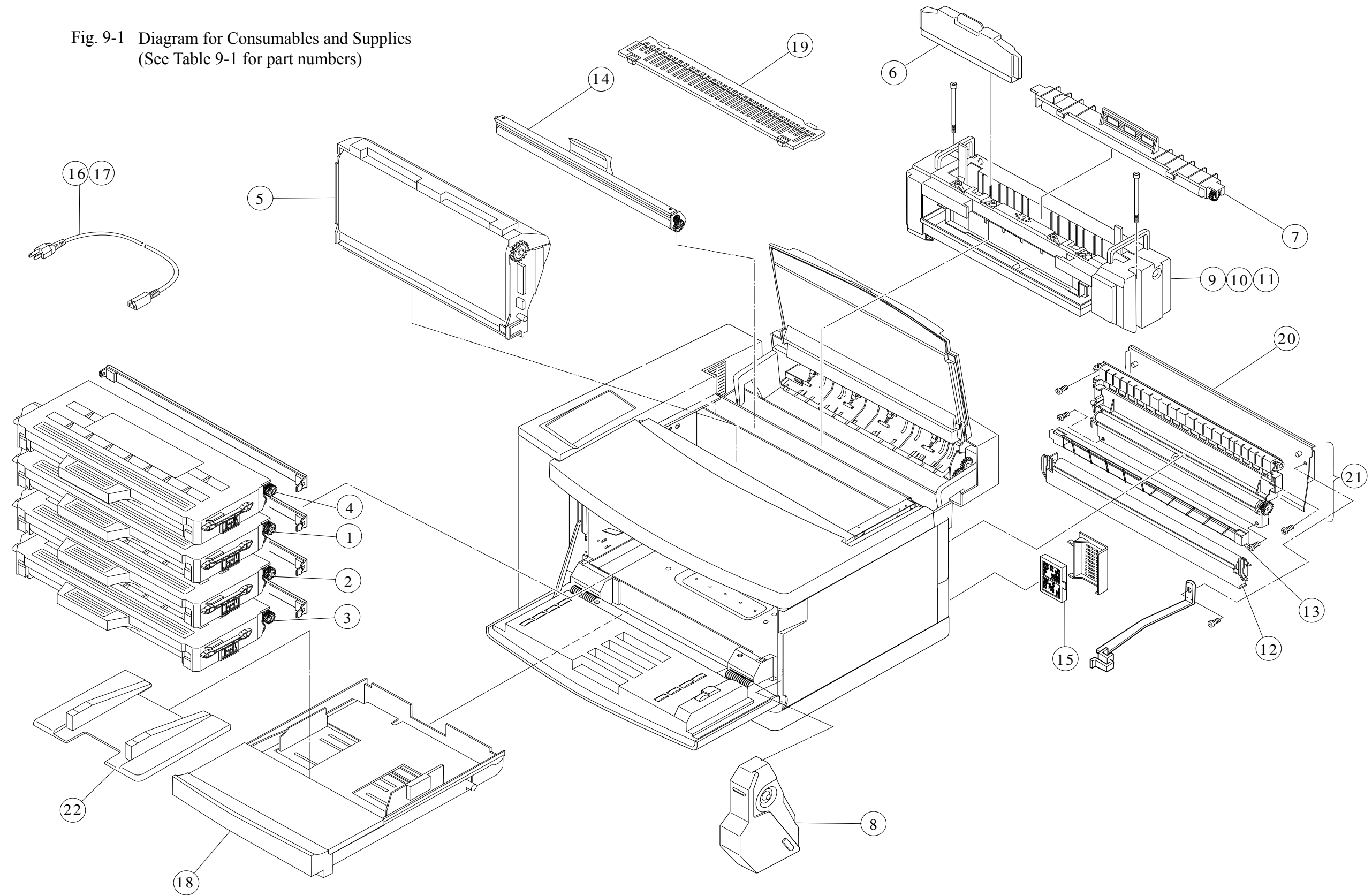

Table 9-2: Spare Parts List (Engine Breakdown #1)

Ref. Number ^a	Part Name	Part Number	Remarks
1	Top Cover	825126601	
2	Right Side Cover	825126602	
3	Left Side Cover	825126603	
4	Left-upper Side Cover	825126605	
5	Front Cover	825126608	
6	Paper Exit Unit Cover	825126610	
7	Paper Exit Front Cover	825126661	
8	Right Base Cover	825126614	
9	Left Base Cover	825126615	
10	Rear Cover	825126616	
11	Upper Rear Cover	825126617	
12	Side F Cover (L)	825126604	
13	Paper Exit Upper Cover	825126611	
14	Upper Rear Cover Cap	825126654	
15	Front Cover Unit	825126607	
16	MCTL P.W.B.	825126649	
16'	MCTL P.W.B. (EC) 3F	825126709	For Flicker
17	High Voltage Power Supply(HVPS)	825126652	
18	Panel Button	825126111	
19	Panel P.W.B.	825126112	
20	Discharge Brush	825126613	
21	Cooling Fan (EX)	825126659	
22	Paper Exit Filter	851126660	

Table 9-2: Spare Parts List (Engine Breakdown #1)

Ref. Number ^a	Part Name	Part Number	Remarks
23	Ozone Filter Cover	825126402	
24	Paper Sensor PT2	825126167	
25	Cleaning Roller Sensor	825126167	
267	Paper Exit Unit	825126609	
27	Paper Exit Roller	825126612	
28	Paper Exit Full Sensor	825126167	
29	Panel Case Assembly	825126606	
30	EP3 CR Sensor Lever	825126174	
31	BC Terminal 3	825126704	

a. See Fig. 9-2 for an illustration of these parts.

Fig. 9-2 Diagram of Engine Parts (Breakdown #1)
(See Table 9-2 for part numbers)

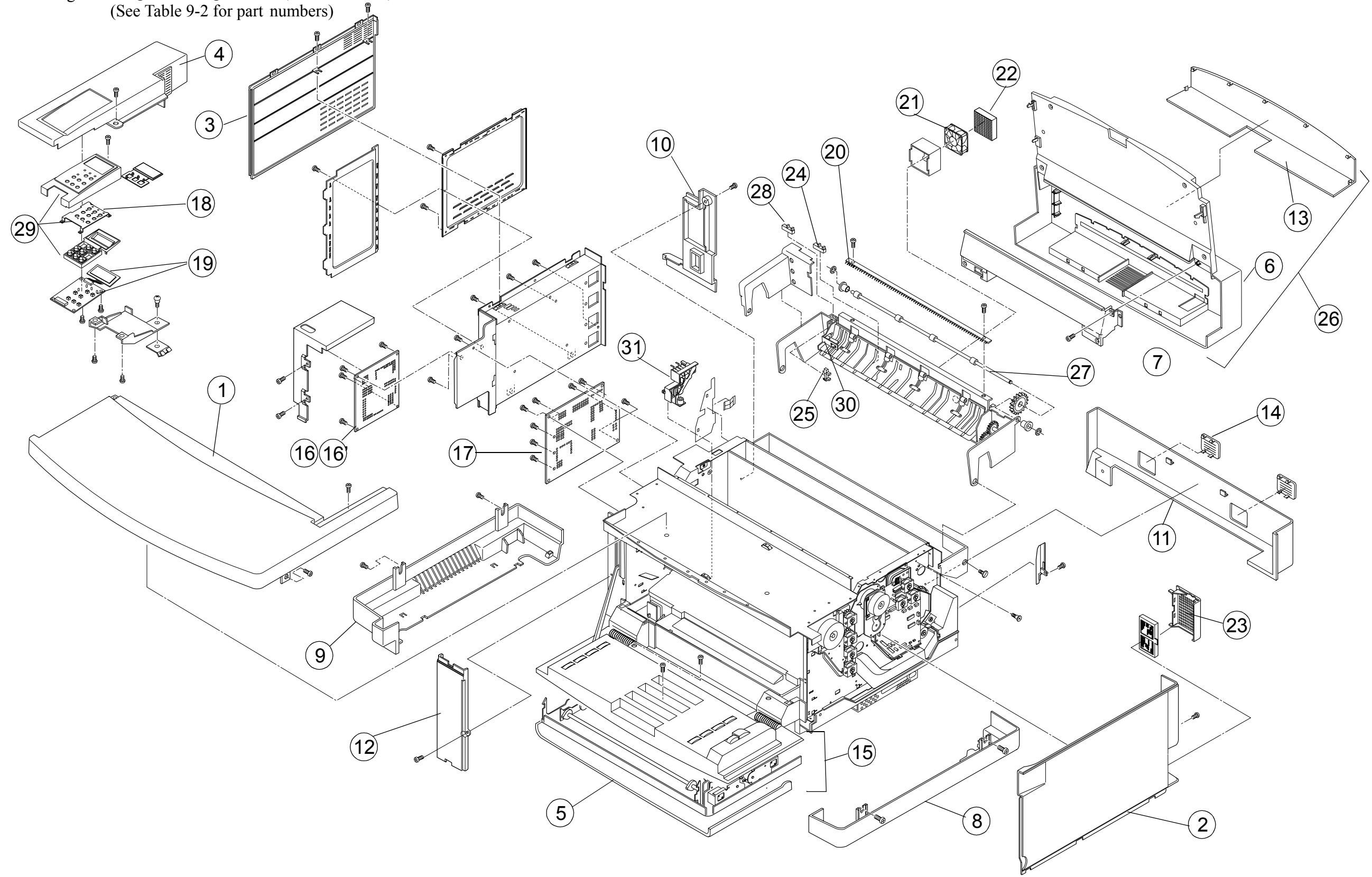

Table 9-3: Spare Parts List (Engine Breakdown #2)

Ref. Number ^a	Part Name	Part Number	Remarks
1	Paper Feeding Clutch	825126152	
2	Registration Clutch	825126153	
3	Fuser Clutch	825126637	
4	Developer Clutch	825126638	DCLK, DCLY, DCLM, DCLC
5	TR Cam Clutch	825126639	
6	FB Cam Clutch	825126639	
7	Cleaner Clutch	825126662	
8	Main Motor	825126640	
9	Main Gear Unit	825126642	
10	Developer Drive Motor	825126643	
11	Developer Drive Unit	825126644	
12	Paper Sensor (Drum Encoder)	825126167	EN
13	BD 3 Gear Assembly	825126641	
14	Low Voltage Power Supply (EC)	825126633	
14'	Low Voltage Power Supply (EC)	825126708	For Flicker
15	Low Voltage Power Supply (US)	825126634	
16	Fuser Connector	825126635	
17	Interlock Switch	825126817	Front, Back, Top
18	Toner Sensor Assembly (P.W.B.)	825126647	
19	IOD2 P.W.B.	825126651	
20	Cooling Fan (PS)	825126655	Controller
21	Cooling Fan (OZ)	825126163	Ozone
22	Waste Toner Feeder (U)	825126618	
23	Optical Unit	825126629	

Table 9-3: Spare Parts List (Engine Breakdown #2)

Ref. Number ^a	Part Name	Part Number	Remarks
24	Transfer Drum	825126631	600,000
25	Erase Lamp	825126632	
26	Oil Sensor	825126145	Oil
27	Belt Sensor	825126168	PBS
28	IOD1 P.W.B.	825126650	
29	Drum Jam Sensor	825126168	DJP
31	Fuser Heater (US)	825126622	
32	Fuser Heater (EC)	825126623	
33	Fuser Heater (JP)	825126624	
34	Oil Pan	825126663	
35	Waste Toner Feeder (L)	825126653	
36	WT Holder Assembly	825126656	WTS
37	SW Button	825126658	
38	Ozone Filter (PS)	825126671	
39	Toner Key Sensor	825126670	
40	SL3 Paper Guide D	825126697	
41	Dev. Drive Gear 3 (4 pcs.)	825126707	
42	MD Gear 15 (Set)	825126713	
43	WT Toner Auger (U)	825126712	
44	Fuser Cover (L) 3	825126705	
45	Fuser Cover (R) 3	825126706	
46	FU3 Felt A'ssy	825126774	
47	FU3 Cover F A'ssy	825126673	
48	SL3 BR Felt A/ssy	825126715	

a. See Fig. 9-3 for an illustration of these parts.

Fig. 9-3 Diagram of Engine Parts (Breakdown #2)
(See Table 9-3 for part numbers)

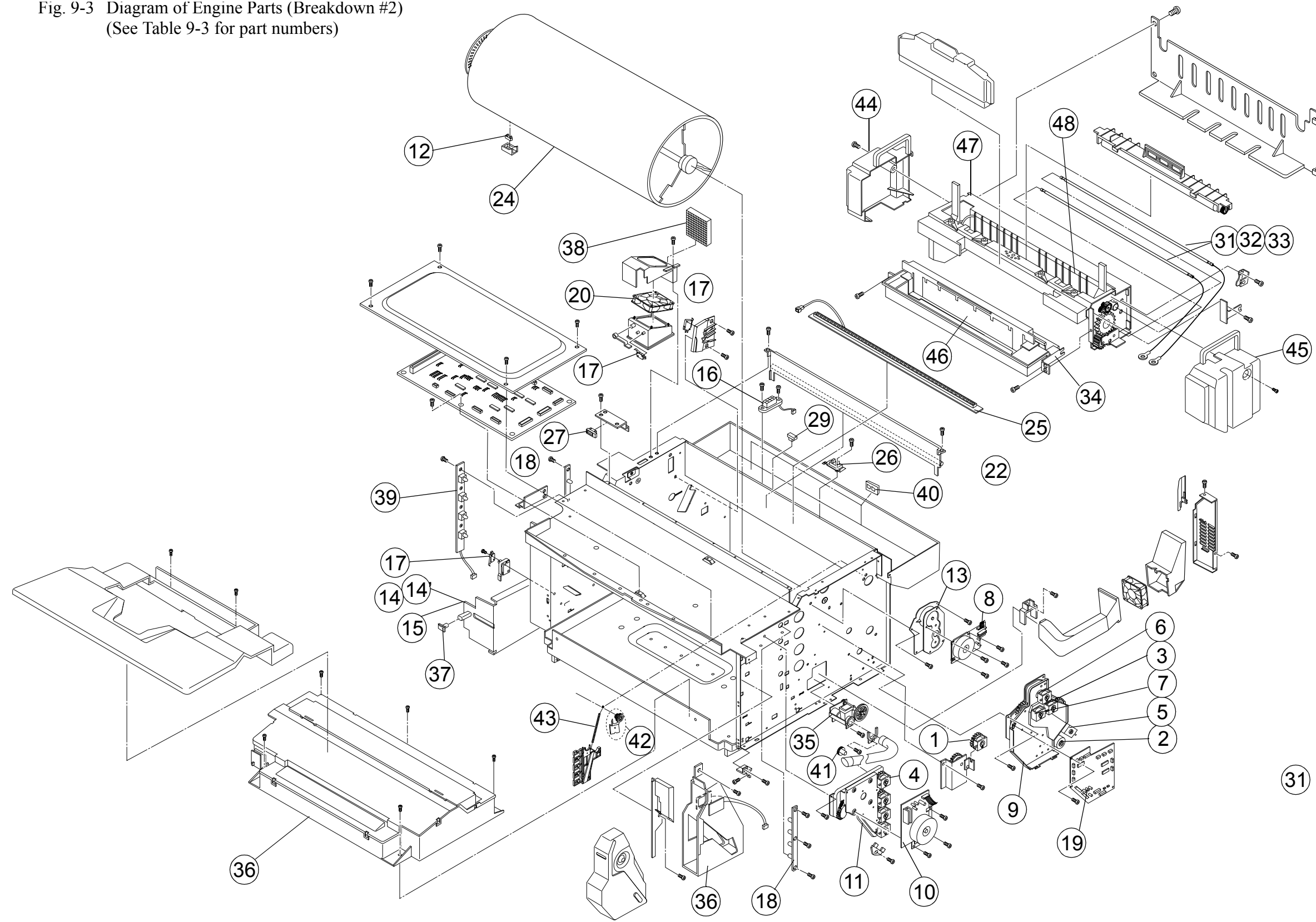

Table 9-4: Spare Parts List (Engine Breakdown #3)

Ref. Number ^a	Part Name	Part Number	Remarks
1	Paper Feeding Roller	825126142	120,000 pages
2	Separator Pad	825126528	120,000 pages
3	OHP Sensor	825126648	
4	Paper Empty Sensor	825126167	
5	Paper Sensor PT1	825126167	
6	Paper Size Sensor	825126646	

a. See Fig. 9-4 for an illustration of these parts.

Fig. 9-4 Diagram for Engine Parts (Breakdown #3)
(See Table 9-4 for part numbers)

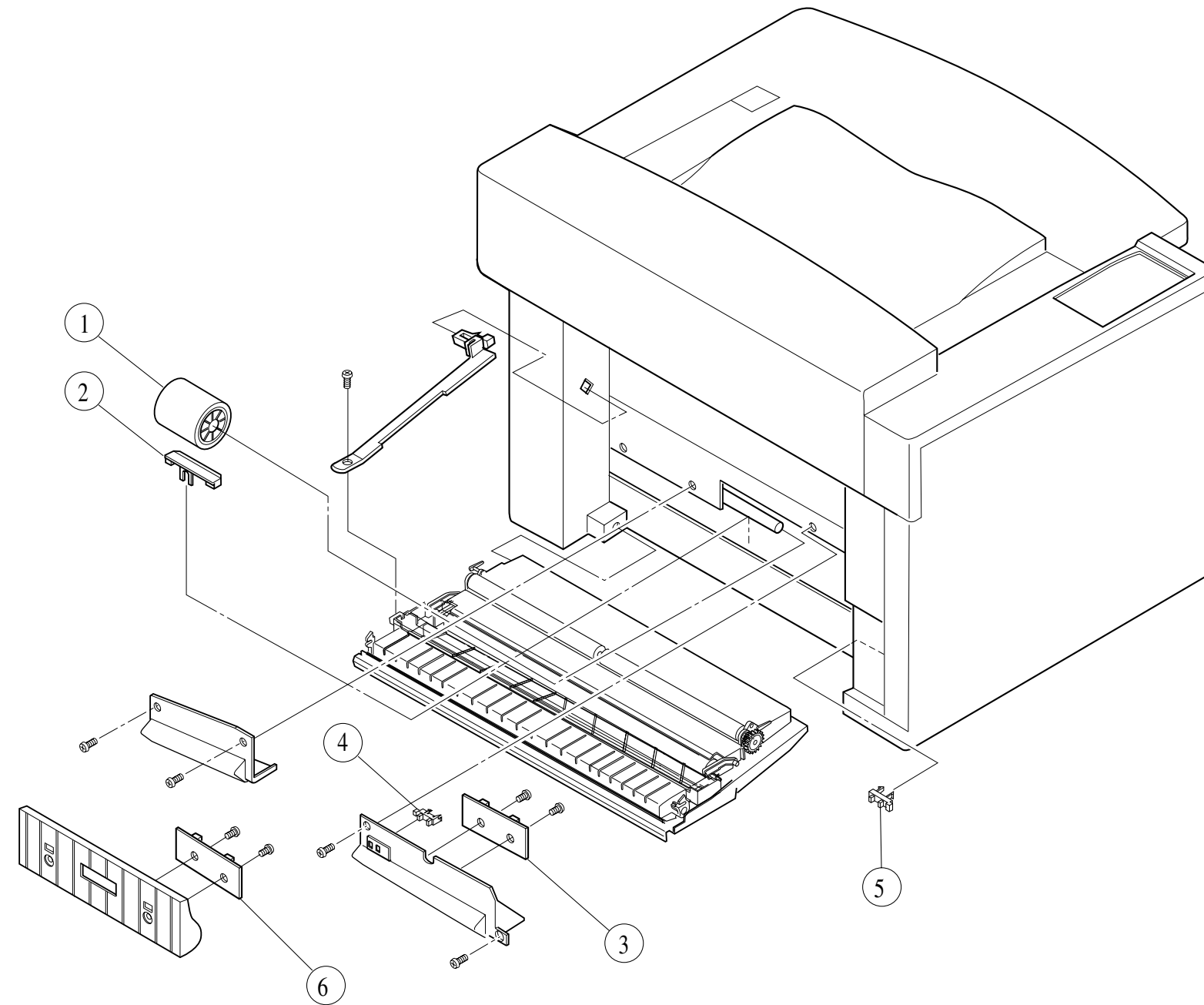

Table 9-5: Duplexer Spare Parts List Breakdown

Ref. Number ^a	Part Name	Part Number	Remarks
1	Top Cover	825126675	
2	Top-left Cover	825126676	
3	Top-right Cover	825126677	
4	Top-rear Cover	825126678	
5	Lower-left Cover	825126679	
6	Lower-right Cover	825126680	
7	Lower-rear Cover	825126681	
8	Bottom Cover	825126681	
9	Paper Guide Bottom Assembly	825126682	
10	Reverse Paper Guide Unit	825126683	
11	Reverse Input Paper Guide	825126684	
12	Paper Guide - U	825126692	
14	Duplexer P.W.B	825126693	
15	Relay P.W.B	825126686	
16	Motor	825126230	DPM1; DPM2
17	Fan Motor	825126687	
18	Upper Solenoid	825126688	
19	Lower Solenoid	825126689	
20	Interlock Switch	825126817	D-SW1 d~D-SW4
21	Sensor PT4	825126690	
22	Sensor PT5	825126691	

a. See Fig. 9-5 for an illustration of these parts.

Fig. 9-5 Diagram of Duplexer Spare Parts Breakdown
(See Table 9-5 for part numbers)

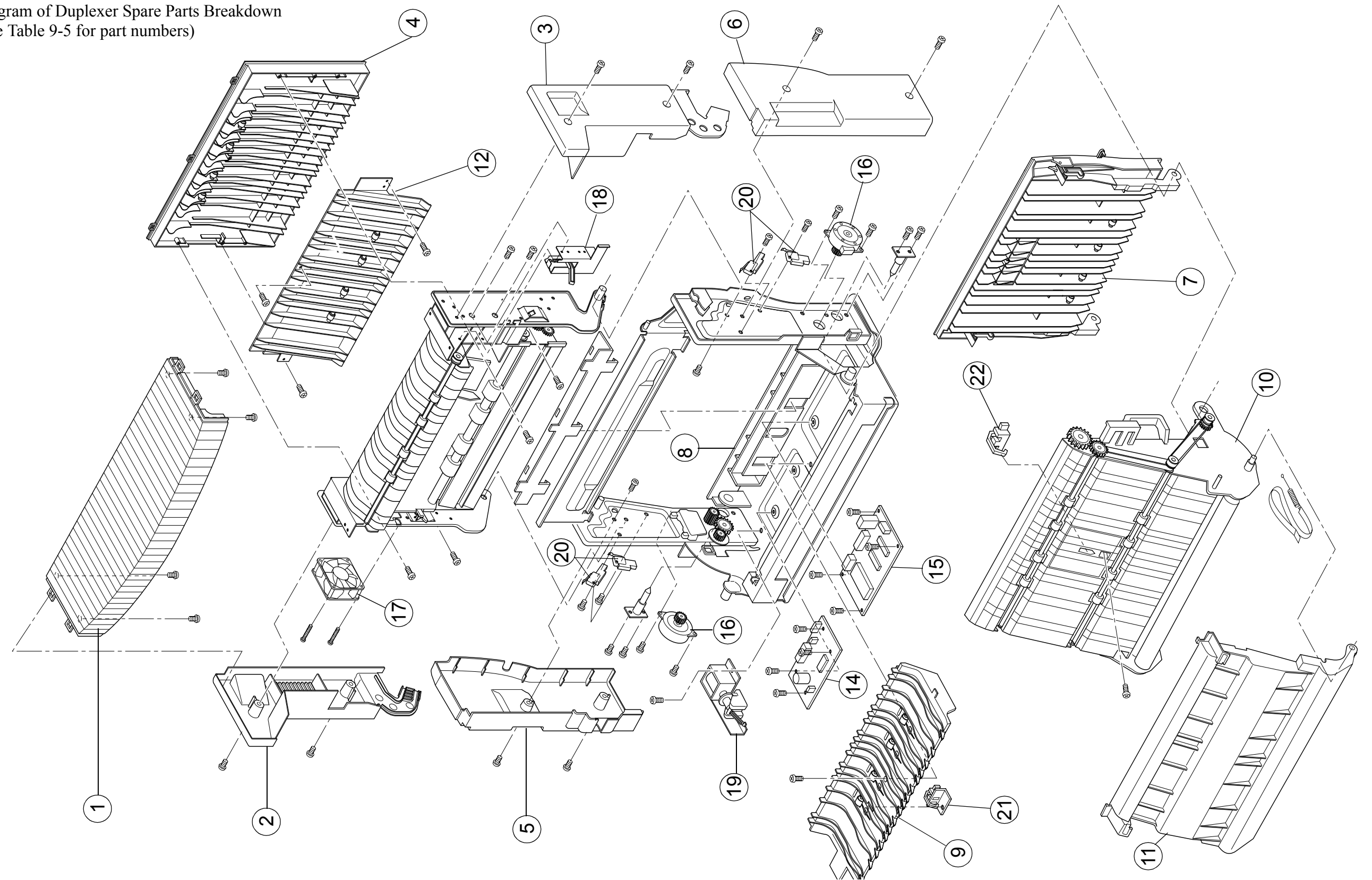
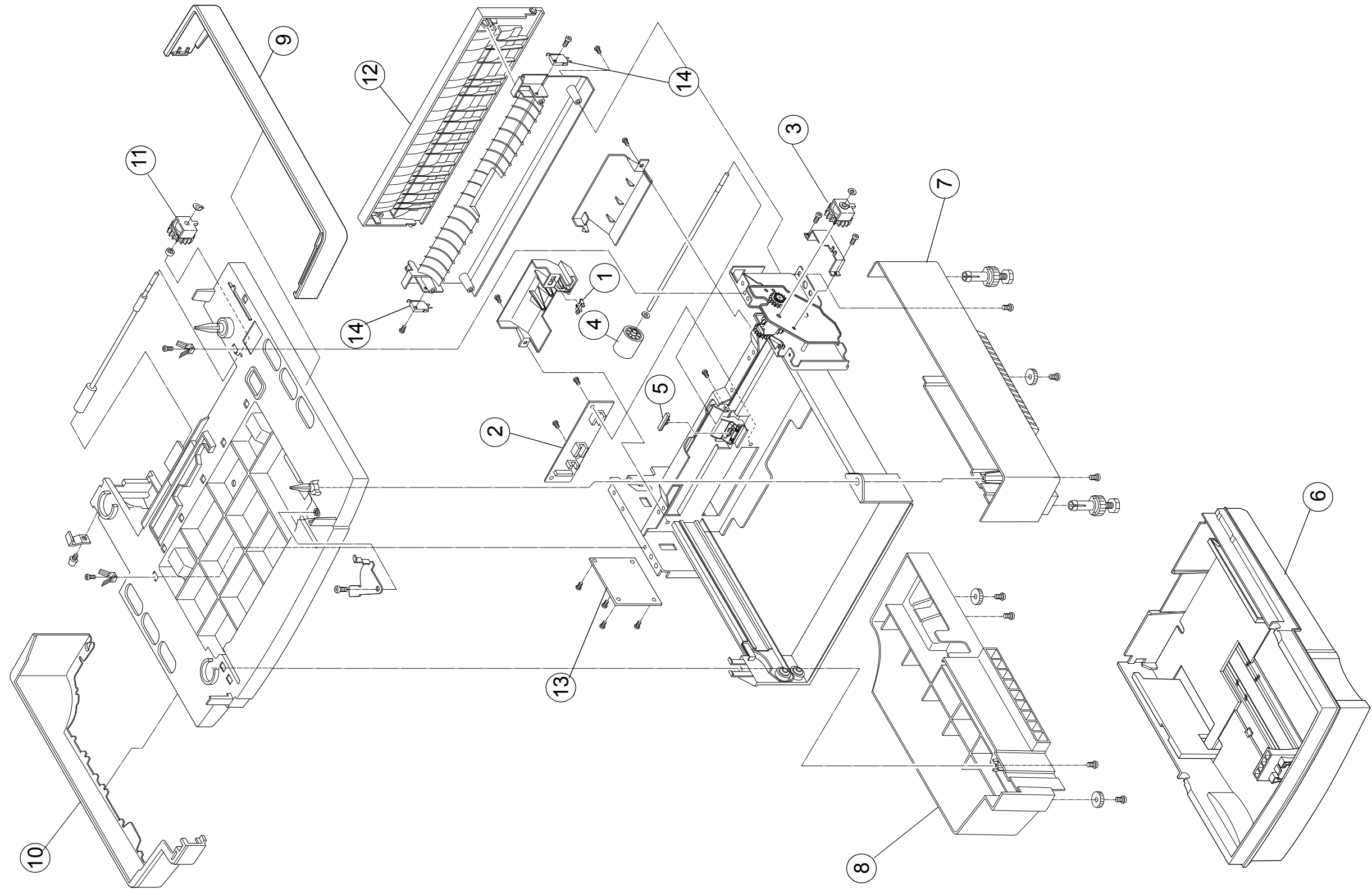

Table 9-6: Lower Feed Unit Spare Parts List Breakdown

Ref. Number ^a	Part Name	Part Number	Remarks
1	Paper Sensor	825126167	To sense the availability of paper.
2	Paper Size Sensor	825126646	To sense the size of paper in the paper cassette.
3	Paper Feeding Clutch	825126152	To drive the paper feeding roller.
4	Paper Feeding Roller	825126142	To automatically feed paper from cassette.
5	Separator Pad	825126528	Prevents multiple sheets from being fed.
6	Paper Cassette	1710375-001	Holds 250 sheets.
7	Right Base Cover	825126699	Right base cover.
8	Left Base Cover	825126700	Left base cover.
9	Right Side Cover	825126664	Right side cover.
10	Left Side Cover	825126665	Left side cover.
11	Paper Transportation Clutch	825126666	Drives the paper transportation roller.
12	LF3 Rear Cover Assy	825126668	Rear cover
13	IOD3 PWB Assy	825126669	IO Board
14	Interlock Switch	825123817	Micro switch for printer door

a. See Fig. 9-6 for an illustration of these parts.

Fig. 9-6 Diagram of Lower Feed Unit Spare Parts Breakdown
(See table 9-6 for part numbers)



Index

Index

A

ACV Tune Up, Factory Mode Procedures 6-32
Adjustment Procedures 6-37

B

Back Stain 8-92
Background 8-72
Banding 8-83
BD Check, Factory Mode Procedures 6-22
Belt Cleaning, Process of 4-18
Belt Discharging, Process of 4-17
Belt Marker Sensor, Replacement 7-62
Black Line 8-80

C

Call For Service Error Code

C3 8-38
C4 8-38
C7 8-38
D1 8-38
D2 8-38
D3 8-38
D4 8-38
D5 8-38
D6 8-38
E1 8-38
E2 8-38
E3 8-38
E4 8-38
E5 8-38
E6 8-38
E7 8-38
E8 8-38
E9 8-38
EL 8-38
F0 8-38
F2 8-38
F4 8-39

F5 8-39
H0 8-39
H2 8-39
H3 8-39
H4 8-39
L1 8-39
L2 8-39
LL 8-39
P1 8-39
P3 8-39
P4 8-39
P5 8-39
P6 8-39

Cassette Installation 3-12
Cassette Type, Service Mode Procedures 6-15
CBV Tune Up, Factory Mode Procedures 6-30
Charging, Process of
 Charger Unit 4-11
Cleaner Cover, Replacement of 7-17
Cleaning
 Belt Cartridge (OPC) 5-10
 Cycle Table 5-6
 Dustproof Glass 5-11
 General 5-5
 Paper Discharger /AC Charger 5-9
 Printer Interior 5-12
 Registration Roller 5-7
 Transfer Roller 5-8
Cleaning Roller 4-21
Cleaning Roller Installation 3-9
Cleaning Roller Sensor CRS, Replacement 7-66
Cleaning the Belt 4-18
Cleaning the Drum 4-21
Clear Care, Service Mode Procedures 6-18
Clutch Replacement
 Developer Clutch (DVCL) 7-50
 FBCL 7-48
 FBCM 7-48
 FUCL 7-48
 Paper Feeding Clutch (PCLC) 7-49
 RECL 7-48
 TRCM 7-48
Clutches (FUCL, FBCL, RECL, FBCM, TRCM), Replacement 7-48

- Clutches, Replacement 7-47
- Clutches, Theory and Layout 4-31
- Color Misregistration 8-88
- Color Printing, Basics 4-5
- Color Theory 4-5
- Component, Name and Functions 1-3
- Connector Pin Assignments 4-50
- Control Block Diagram 4-33
- Control System, Theory 4-27
- Control System, Theory and Layout 4-33
- Controller Fan, Replacement 7-44
- Cover Replacement
 - Left Side Cover 7-8
 - Left-front Side Cover 7-9
 - Left-upper Side Cover 7-6
 - Right Side Cover 7-7
- Covers, Replacement 7-5
- Current 2-3

D

- DBV Tune Up, Factory Mode Procedures 6-29
- Detact 4-20
- Developer Clutch (DVCL), Replacement 7-50
- Developer Gear Unit, Replacement 7-40
- Developer Motor, Replacement 7-38
- Developing, Process of 4-13
- Discharger Brush, Replacement 7-76
- Discharging the Belt 4-17
- Display Modes, Operator Panel 6-4
- DP Check, Factory Mode Procedures 6-21
- Drum Cleaner, Replacement 5-22
- Drum Cleaning, Process of 4-21
- Drum Encoder Sensor (EN), Replacement 7-61
- Drum Jam Sensor DPJ, Replacement 7-59
- Duplex Jams 8-36
- Duplexer
 - Bottom Cover, Replacement 7-91
 - Bottom Paper Guide, Replacement 7-94
 - Fan Motor, Replacement 7-100
 - Interlock Switches (1 & 2), Replacement 7-103
 - Interlock Switches (3 & 4), Replacement 7-104
 - Lower Solenoid, Replacement 7-102

- Lower-left Cover, Replacement 7-85
- Lower-rear Cover, Replacement 7-90
- Lower-right Cover, Replacement 7-84
- Motor (1), Replacement 7-98
- Motor (2), Replacement 7-99
- P.W.B., Replacement 7-96
- Paper Sensor Low PT4, Replacement 7-106
- Paper Sensor PT5, Replacement 7-105
- Relay P.W.B., Replacement 7-97
- Reverse Input Paper Guide, Replacement 7-93
- Reverse Paper Guide Unit, Replacement 7-92
- Top Cover, Replacement 7-89
- Top-left Cover, Replacement 7-87
- Top-rear Cover, Replacement 7-88
- Top-right Cover, Replacement 7-86
- Upper Solenoid, Replacement 7-101
- Duplexer Components, Replacement 7-83
- Duplexer Pin Assignments 4-67
- Duplexer, Function of Components 1-4
- Duplexer, Internal Structure 1-7
- Duplexer, Unpacking 3-8

E

- Each Image Reset, Factory Mode Procedures 6-35
- Each Image, Service Mode Procedures 6-17
- Electrical Components, Function and Theory 4-29
- Electrical System 4-27
- Electrophotographic Process 4-9
- Empty Sensor (PE) / OHP Sensor (OHP), Replacement 7-57
- Engine Error Code
 - C3 8-38
 - C4 8-38
 - C7 8-38
 - D1 8-38
 - D2 8-38
 - D3 8-38
 - D4 8-38
 - D5 8-38
 - D6 8-38

E1 8-38
 E2 8-38
 E3 8-38
 E4 8-38
 E5 8-38
 E6 8-38
 E7 8-38
 E8 8-38
 E9 8-38
 EL 8-38
 F0 8-38
 F2 8-38
 F4 8-39
 F5 8-39
 H0 8-39
 H2 8-39
 H3 8-39
 H4 8-39
 L1 8-39
 L2 8-39
 LL 8-39
 P1 8-39
 P3 8-39
 P4 8-39
 P5 8-39
 P6 8-39
 Envelope Adapter 3-12
 Environmental Conditions 2-8
 Erase Lamp 4-17
 Erase Lamp, Replacement 7-32
 Error Codes, Operator Call 8-4
 Error Resolution
 Beam Sensor Error 8-39
 Belt Sensor Error 8-38
 Brush Cleaner Clutch Error 8-38
 Brush Cleaner Solenoid Error 8-38
 Charging HV (HVPS) Error 8-39
 Clutch Error of Black Developing Unit 8-38
 Clutch Error of Cyan Developing Unit 8-38
 Clutch Error of Fusing Unit 8-38
 Clutch Error of Magenta Developing Unit 8-38
 Clutch Error of Yellow Developing Unit 8-38
 Control Fan Error 8-38
 DCTL Error 8-39
 Developing Motor Error 8-38
 Duplex Fan Error 8-39
 Duplex Solenoid Error 8-39
 Duplexer Motor Error 8-39
 Engine Controller MCTL P.W.B. Hardware Error 8-38
 Erase Lamp Error 8-38
 Fusing Fan Error 8-39
 Fusing Temperature (3) Error 8-39
 Fusing Temperature (4) Error 8-39
 Fusing Temperature Error 8-39
 Fusing Thermistor Error 8-39
 HPSI Signal Error (Retract Error of Black and Yellow Toner Cartridge) 8-38
 HPSI Signal Error (Retract Error of Cyan and Magenta Toner Cartridge) 8-38
 Laser Power Error 8-39
 Main Motor Error 8-38
 NVRAM Error (MCTL P.W.B.) 8-38
 Ozone Fan (1) Error 8-38
 P3 Duplexer Solenoid Error 8-39
 Process Timing Clock Error (Main Motor Clock Error) 8-38
 Scanner Motor Error 8-39
 Toner Empty Sensor Error (TPD) 8-38
 Transfer Drum Rotational Error 8-38
 Transfer Roller Solenoid Error 8-38
 Exposing, Process of 4-12

F
 FBV Tune Up, Factory Mode Procedures 6-31
 First Transfer 4-16
 First Transfer, Process of 4-15
 Frequency 2-3
 Front Cover Unit, Replacement 7-73
 Front Cover, Replacement 7-18
 FU Check, Factory Mode Procedures 6-23
 Functions of Printer Components 4-8
 Fuser Connector, Replacement 7-78
 Fuser Oil Caution 5-18
 Fuser, Replacement 5-17
 Fuser, Theory 4-25

Fusing Temperature 4-26
Fusing Temperature, Control of 4-35

H

Handling Precautions 5-3
Heater Fan, Replacement 7-45
Heater Lamp (HR/BR), Replacement 7-81
High Voltage Power Supply, Replacement 7-30
High Voltage Power Supply, Theory of 4-44
Humidity 2-8
HVPS 4-44

I

Imaging Error Resolution
 Back Stain 8-92
 Background 8-72
 Banding 8-83
 Black Line 8-80
 Color Misregistration 8-88
 Insufficient Fusing 8-94
 Insufficient Gloss 8-91
 Jitter 8-74
 Missing Image at Edge 8-73
 Mixed Color Image 8-87
 Mottle 8-89
 Residual Image 8-90
 Ribbing 8-75
 Toner Drop 8-85
 Vertical Line 8-81
 Vertical Staggering Image 8-82
 Vertical White Band 8-79
 White Band 8-84
 White Line, I 8-77
 White Line, II 8-78
 White Print 8-93
 White Spot / Black Spot 8-86
 Wrinkle / Image Migration 8-76
Imaging Failures 8-72
Initial Setting of NVRAM 6-43
Inner Jams 8-35
Installation

Cleaning Roller and Oil Bottle 3-9
Duplex Unit 3-18
LFU 3-15
OPC Belt Cartridge 3-10
Paper Cassette and Adapter 3-12
Test Print 3-22

Toner Cartridges 3-11
Installation, Consumables 3-9
Installation, Environmental Conditions 3-3
Insufficient Fusing 8-94
Insufficient Gloss 8-91
Interface Control 4-38
 Connector Pin Assignment 4-40
Interlock Switch, Replacement 7-52
IOD1 PWB, Replacement 7-22
IOD2 PWB, Replacement 7-24

J

Jam Errors 8-34
Jitter 8-74

L

Laser Drive Control Circuit (LDC) 4-34
Laser Unit 4-22
Laser Unit Cleaning 5-11
LDC 4-34
LED, Erase 4-17
Left Access Plate Interlock Switch, Replacement 7-54
Left Base Cover, Replacement 7-16
Left Margin Adjustment, Duplexer Installed 6-38
Left Side Cover, Replacement 7-8
Left-front Side Cover, Replacement 7-9
Left-upper Side Cover, Replacement 7-6
LFU
 Interlock Switch, Replacement 7-112
 IOD3 P.W.B. Assembly, Replacement 7-113
 Paper Feeder Clutch, Replacement 7-109
 Paper Feeder Roller, Replacement 7-111
 Paper Sensor PEL, Replacement 7-107

- Paper Size Sensor, Replacement 7-108
- Paper Transportation Clutch, Replacement 7-109
- Separator Pad, Replacement 7-111
- LFU Installation 3-15
- LFU, Function of Components 1-5
- LFU, Unpacking 3-7
- Life Period Set, Factory Mode Procedures 6-25
- List of Consumables for Maintenance 5-5
- Low Voltage Power Supply, Replacement 7-28
- Low Voltage Power Supply, Theory of 4-41
- Lower Feed Unit Components, Replacement 7-107
- LP Tune Up, Factory Mode Procedures 6-27
- LVPS 4-41

M

- Main Gear Unit, Replacement 7-36
- Main Motor / Main Motor Assembly, Replacement 7-34
- Maintenance Codes 5-14
- Maintenance Cycles 5-13
- Maintenance Tools 5-4
- Maintenance, Consumables Needed 5-5
- Margin Adjust, Factory Mode Procedures 6-24
- Margin Adjustment 6-37
- MCTL PWB, Replacement 7-20
- Mechanical and Electrical Structures 4-3
- Media 2-7
- Media Manage, Service Mode Procedures 6-19
- Media Specifications 2-7
- Misfeed Jams 8-35
- Missing Image at Edge 8-73
- Mixed Color Image 8-87
- Molybdenum Grease 5-5
- Motor Replacement
 - Controller Fan 7-44
 - Developer Gear Unit 7-40
 - Developer Motor 7-38
 - Heater Fan 7-45
 - Main Gear Unit 7-36
 - Main Motor 7-34
 - Optical Unit 7-42
 - Ozone Fan 7-46

- Motors and Switches, Layout and Theory 4-30
- Motors, Replacement 7-33
- Mottle 8-89

N

- Next Care Procedures 6-14
- Next Life Set, Factory Mode Procedures 6-36
- Normal Mode 6-4
 - Messages 6-4
 - Operation 6-7
- NVRAM Initialization, Factory Mode Procedures 6-33
- NVRAM Tune Up, Factory Mode Procedures 6-26

O

- Oil Bottle Installation 3-9
- Oil Pan Unit, Replacement 7-82
- Oil Sensor (OIL), Replacement 7-60
- OPC Belt Cartridge, Replacement 5-15
- OPC Belt, Structure 4-6
- OPC Cleaning 5-10
- OPC Installation 3-10
- Operator Call Error
 - ADJUST "INPUTBIN" BIN 8-4
 - BELT CARTRIDGE MIS-INSTALLED 8-5
 - CHECK CLEANING ROLLER 8-5
 - CHECK WASTE TONER 8-5
 - CLEANING ROLLER MISINSTALLED 8-5
 - DRUM JAM 8-5
 - DUPLEX JAM 8-5
 - DUPLEX UNIT PANEL OPEN 8-6
 - ENERGY SAVER 8-6
 - FUSER MISINSTALLED 8-5
 - FUSER OIL EMPTY 8-5
 - FUSER OIL LOW 8-5
 - IDLE 8-6
 - INNER JAM 8-5
 - INPUT IDLE PRINTING 8-6
 - MISFEED JAM 8-5

OUTER JAM 8-5
 OUTPUT BIN FULL 8-4
 PUT "SIZE" PAPER IN "INPUTBIN"
 BIN 8-4
 PUT "SIZE" PAPER IN ANY BIN 8-4
 PUT "SPECIAL MEDIA" IN UPPER BIN
 8-4
 WARMING UP 8-6
 x DOOR OPEN 8-6
 x TONER EMPTY 8-4
 x TONER LOW 8-4
 x TONER MISINSTALLED 8-5
 Operator Call Error Code (persistent) Resolu-
 tions 8-7
 Operator Call Error Resolutions 8-4
 Operator Error Resolution
 'X' TONER LOW/EMPTY 8-7
 ADJUST 'n' BIN 8-7
 ALIGN BELT CG 8-7
 ALIGN FU UNIT 8-7
 ALIGN FUSER CL ROLLER 8-7
 ALIGN LFU 8-8
 ALIGN TONER CG Y/M/C/K 8-7
 ALIGN TR ROLLER 8-7
 CHECK CLEANING ROLLER 8-7
 CHECK MEDIA 8-7
 CHECK WASTE TONER 8-7
 CHK MEDIA FOR DUPLEX 8-7
 CLOSE PANEL FRONT/TOP 8-8
 DRUM JAM 8-8
 DUPLEX JAM 8-8
 DUPLEX UNIT PANEL OPEN 8-8
 FUSER OIL LOW/EMPTY 8-7
 INNER JAM 8-8
 MISFEED JAM 8-8
 MISPRINT PAPER/NOPRQ/MEDIA/DU-
 PLEX 8-7
 NO MEDIA UPP/LF1/LF2 8-7
 OUTER JAM 8-8
 OUTPUT BIN FULL 8-7
 PUT 'SIZE' IN ANY BIN 8-7
 REAR DOOR OPEN 8-8
 Operator Panel 1-8
 Operator Panel, description of 1-8
 Operator Panel, Operation and Adjustments 6-

3
 Optical System, Structure 4-22
 Optical Unit 4-12
 Optical Unit Cleaning 5-11
 Optical Unit, Replacement 7-42
 Optical Unit, Specifications 4-23
 Outer Jams 8-36
 Ozone Fan and Duct Assembly, Replacement
 7-46
 Ozone Filter, Replacement 5-24

P

Panel PWB, Replacement 7-26
 Paper Discharger Cleaning 5-9
 Paper Discharger, Replacement 5-21
 Paper Discharging, Process of 4-20
 Paper Exit Cover / Paper Exit Front Cover, Re-
 placement 7-11
 Paper Exit Cover Interlock Switch, Replace-
 ment 7-53
 Paper Exit Sensor PT2, Replacement 7-56
 Paper Exit Unit/Paper Exit Roller, Replace-
 ment 7-74
 Paper Feed Roller / Separator Pad, Replace-
 ment 7-72
 Paper Feeding Clutch (PCLC), Replacement 7-
 49
 Paper Feeding Roller, Replacement 5-25
 Paper Full Sensor PFUS, Replacement 7-67
 Paper Jam Troubleshooting 8-35
 Duplex Jams 8-36
 Inner Jams 8-35
 Misfeed Jams 8-35
 Outer Jams 8-36
 Paper Sensor PT1, Replacement 7-55
 Paper Separation 4-20
 Paper Size Sensor PSU, Replacement 7-58
 Paper Specifications 2-7
 Paper Transport Errors 8-34
 Paper Transportation System 4-24
 Parts Breakdown, Consumables and Supplies
 9-3
 Parts Breakdown, Duplexer 9-19
 Parts Breakdown, Engine Breakdown #1 9-7

- Parts Breakdown, Engine Breakdown #2 9-11
- Parts Breakdown, Engine Breakdown #3 9-15
- Parts Breakdown, LFU 9-23
- Periodic Maintenance 5-3
- Periodic Maintenance Cycles and Procedures 5-13
- Periodic Maintenance, Cleaning 5-5
- Periodic Maintenance, Cleaning Cycle Table 5-6
- Periodic Maintenance, Cleaning Procedures 5-7
- Photoconductor 4-6
- Pin Assignments, Duplexer 4-67
- PM Cycles 5-13
- Power Cord 2-3
- Power Rating 2-3
- Power Supply Pin Assignment 4-41
- Print System and Transfer/Transport System 4-7
- Printed Wire Boards, Replacement 7-19
- Printer Errors (non-Operator Call Errors) 8-37
- Printer Interior Cleaning 5-12
- Printer Structure 4-8
- Printer Weight 3-4
- Printer, Function of Components 1-3
- Printer, Internal Structure 1-6
- Process of Fusing 4-26
- Processes of the Print System 4-9
- PWB Layout 4-29
- PWB Replacement
 - Erase Lamp 7-32
 - High Voltage Power Supply 7-30
 - IOD1 PWB 7-22
 - IOD2 PWB 7-24
 - Low Voltage Power Supply 7-28
 - MCTL PWB 7-20
 - Panel PWB 7-26

R

- Rear Cover, Replacement 7-13
- Recommended Media 2-7
- Registration Roller Cleaning 5-7
- Registration Roller, Replacement 7-70
- Replacement

- Cleaner Cover 7-17
- Clutches 7-47
- Covers 7-5
- Discharger Brush 7-76
- Drum Cleaner 5-22
- Duplexer Components 7-83
- Front Cover 7-18
- Front Cover Unit 7-73
- Fuser 5-17
- Fuser Connector 7-78
- Heater Lamp 7-81
- Left Base Cover 7-16
- LFU Components 7-107
- Motors 7-33
- Oil Pan Unit 7-82
- OPC 5-15
- Ozone Filter 5-24
- Paper Discharger 5-21
- Paper Exit Cover / Paper Exit Front Cover 7-11
- Paper Exit Roller 7-74
- Paper Exit Unit 7-74
- Paper Feed Roller 5-25, 7-72
- PWBs 7-19
- Rear Cover 7-13
- Registration Roller 7-70
- Right Base Cover 7-15
- Rollers, Drums, & Other Components 7-69
- Separation Pad 5-25
- Separator Pad 7-72
- Switches & Sensors 7-51
- Toner Drive Assembly 7-79
- Top Cover 7-10
- Transfer Drum 5-26, 7-71
- Transfer Roller 5-19
- Transfer Unit 7-69
- Transfer Unit Door Cover 7-12
- Waste Toner Auger 7-77
- Replacement Precautions 7-3
- Replacement Procedures 7-3
- Replacement, Duplexer
 - Bottom Cover 7-91
 - Bottom Paper Guide 7-94
 - Duplexer P.W.B. 7-96
 - Duplexer Paper Sensor PT5 7-105

Fan MotoR 7-100
 Interlock Switches (1 & 2) 7-103
 Interlock Switches (3 & 4) 7-104
 Lower Solenoid 7-102
 Lower-left Cover 7-85
 Lower-rear Cover 7-90
 Lower-right Cover 7-84
 Motor (1) 7-98
 Motor (2) 7-99
 Paper Sensor Low PT4 7-106
 Relay P.W.B. 7-97
 Reverse Input Paper Guide 7-93
 Reverse Paper Guide Unit 7-92
 Separation of the Top and Lower Units 7-95
 Top Cover 7-89
 Top-left Cover 7-87
 Top-rear Cover 7-88
 Top-right Cover 7-86
 Upper Solenoid 7-101
 Replacement, LFU
 Components 7-107
 Interlock Switch 7-112
 IOD3 P.W.B. Assembly 7-113
 Paper Feeder Clutch 7-109
 Paper Feeder Roller 7-111
 Paper Sensor PEL 7-107
 Paper Size Sensor 7-108
 Paper Transportation Clutch 7-109
 Separator Pad 7-111
 Residual Image 8-90
 Ribbing 8-75
 Right Base Cover, Replacement 7-15
 Right Side Cover, Replacement 7-7
 Rollers, Drums, & Other Components, Replacement 7-69

S
 Second Transfer, Process of 4-19
 Sensor Replacement
 Belt Marker Sensor 7-62
 Cleaning Roller Sensor CRS 7-66
 Drum Encoder Sensor (EN) 7-61
 Drum Jam Sensor DPJ 7-59
 Empty Sensor (PE) / OHP Sensor (OHP) 7-57
 Oil Sensor (OIL) 7-60
 Paper Exit Sensor PT2 7-56
 Paper Full Sensor PFUS 7-67
 Paper Sensor PT1 7-55
 Paper Size Sensor PSU 7-58
 Toner Key Sensor TNK 7-68
 Toner Sensor Assemblies (TPD and TTR) 7-64
 Waste Toner Sensor 7-63
 Sensors, Layout 4-32
 Separation 4-20
 Separation of the Top and Lower Duplexer Units, Replacement 7-95
 Separator Pad, Replacement 5-25
 Service Mode 6-6
 ACV Tune-Up 6-32
 BD Check 6-22
 Cassette Type 6-15
 CBV Tune-Up 6-30
 Clear Care 6-18
 DBV Tune-Up 6-29
 DP Check 6-21
 Each Image 6-17
 Each Image Reset 6-35
 FBV Tune-Up 6-31
 FU Check 6-23
 Life Period Set 6-25
 LP Tune-Up 6-27
 Margin Adjust 6-24
 Media Manage 6-19
 Next Care 6-14
 Next Life Set 6-36
 NVRAM Initialization 6-33
 NVRAM Tune-Up 6-26
 Operation 6-13
 Procedures 6-12
 Test Print 6-13
 THV Tune-Up 6-28
 Total Page 6-16
 Total Page Reset 6-34
 Setting of NVRAM Data 6-41
 Spare Parts Breakdown 9-3
 Specifications, Duplexer 2-5

Specifications, Lower Feed Unit 2-5
Specifications, Printer 2-4
Starter Kit 3-6
Storage 2-9
Subtractive Color Theory 4-5
Switch Replacement
 Interlock Switch 7-52
 Left Access Plate Interlock Switch 7-54
 Paper Exit Cover Interlock Switch 7-53
Switches & Sensors, Replacement 7-51
Symbol and Part Names, Electrical 4-49

T

Temperature 2-8
Test Print Procedures 3-23
Test Print, Service Mode Procedures 6-13
Theory of Operation 4-3
THV Tune Up, Factory Mode Procedures 6-28
Toner Cartridge Installation 3-11
Toner Cartridge Structure 4-13
Toner Drive Assembly, Replacement 7-79
Toner Drop 8-85
Toner Key Sensor TNK, Replacement 7-68
Toner Sensor Assemblies (TPD and TTR), Replacement 7-64
Top and Left Margin, Adjustment 6-37
Top Cover, Replacement 7-10
Total Page Reset, Factory Mode Procedures 6-34
Total Page, Service Mode 6-16
Transfer Drum Structure 4-15
Transfer Drum, Replacement 5-26, 7-71
Transfer Roller 4-19
Transfer Roller Cleaning 5-8
Transfer Roller, Replacement 5-19
Transfer Unit Door Cover, Replacement 7-12

Transfer Unit, Replacement 7-69
Transportation 2-9
Troubleshooting 8-3

U

Unpacking the Duplexer 3-8
Unpacking the LFU Lower Feed Unit 3-7
Unpacking the Printer 3-4
Unpacking the Starter Kit 3-6

V

Vertical Line 8-81
Vertical Staggering Image 8-82
Vertical White Band 8-79
Voltage 2-3
Voltages, HVPS 4-44

W

Waste Toner Auger, Replacement 7-77
Waste Toner Sensor, Replacement 7-63
Weight 3-4
White Band 8-84
White Line, I 8-77
White Line, II 8-78
White Print 8-93
White Spot / Black Spot 8-86
Wrinkle / Image Migration 8-76

X

Xerographic Process 4-9

